

CMFRI

bulletin 44

Part One

JUNE 1989



NATIONAL SYMPOSIUM ON RESEARCH AND DEVELOPMENT IN MARINE FISHERIES

MANDAPAM CAMP
16-18 September 1987

Papers Presented
Sessions I & II

CENTRAL MARINE FISHERIES RESEARCH INSTITUTE
(Indian Council of Agricultural Research)
P. B. No. 2704, E. R. G. Road, Cochin-682 031, India

Central Marine Fisheries Research Institute
40
YEARS
1947-1987

CMFRI

bulletin 44

Part One

JUNE 1989



NATIONAL SYMPOSIUM ON RESEARCH AND DEVELOPMENT IN MARINE FISHERIES

MANDAPAM CAMP

16-18 September 1987

**Papers Presented
Sessions I & II**



CENTRAL MARINE FISHERIES RESEARCH INSTITUTE
(Indian Council of Agricultural Research)
P. B. No. 2704, E. R. G. Road, Cochin-682 031, India

Bulletins are issued periodically by Central Marine Fisheries Research Institute to interpret current knowledge in the various fields of research on marine fisheries and allied subjects in India.

Copyright Reserved



Published by

P. S. B. R. JAMES

Director

Central Marine Fisheries Research Institute

ERG Road

Cochin-682 031, India

Editorial Committee

Dr K ALAGARSWAMI

Dr K ALAGARAJA

Shri M S MUTHU

Dr K J MATHEW

Dr N GOPINATHA MENON

Limited Circulation

CONTENTS

Technical Session I: NATIONAL FISHERY POLICY AND PLANNING

Marine Fisheries Development — An outlook for 21st century and key policy issues	... U. K. Srivastava	...	1
Growth Profile of Marine Fisheries in India	... P. S. B. R. James	...	10
Planning for Fishery Development — Search for appropriate policy instruments	... A. G. Jhingran and S. Paul	...	28
Monitoring Industrial Effluents Discharge along Gujarat Coast by Bio-Assay Test and Physico Chemical Parameters	... Y. B. Raval and four others	...	33
A Brief Appraisal of Marine Fisheries in India	... K. Alagaraja	...	36

Technical Session II: RESEARCH IN MARINE CAPTURE FISHERIES

Fishery and Biology of Oil Sardine, <i>Sardinella longiceps</i> , from Coastal Waters of Parangipettai	... K. Kumar and K. Subrahmanyam	...	42
On the Fishery and Population Dynamics of Seer Fish <i>Scomberomorus commerson</i> (Lacepede) of Tuticorin	... H. Md Kasim and K. M. S. Ameer Hamsa	...	46
The Present Status of Polynemid Fishery in India	... P. V. Kagwade	...	54
An Assessment of the Bottom-Trawl Fishery Resources of the Northeast Coast of India	... S. Reuben and six others	...	59
The Catfish Resources of South West Coast of India — Prospects and management problems	... P.S.B.R. James and three others	...	78
Migratory Winter Bag-Net Fishery in Coastal Waters of the Hooghly Estuary	... B. N. Saigal, P. M. Mitra and H. C. Karmarkar	...	94
The Shrimp Resources of the Coastal Waters of Kerala and the Effect of Mechanisation	... M. J. George	...	102
Shrimp Fishery of Bombay Coast	... M. Arvindakshan and J. P. Karbhari	...	107
National Strategy for Exploitation and Utilization of the Potential Marine Fishery Resources of India—A projection	... P.S.B.R. James and five others	...	111
Exploitation of Juveniles of Green Tiger Prawn, <i>Penaeus (Penaeus) semisulcatus</i> , along Palk Bay and Its Impact on the Prawn Fishery of the Region	... P. E. Sampson Manickam, M. R. Arputhraj and P. Vedavyasa Rao	...	137
Prospects for Increasing Cephalopod Production of India	... K. Alagarwami and M. M. Meiyappan	...	146
New Trends in the Traditional Marine Fisheries at Tuticorin	... P. Sam Bennet and G. Arumugam	...	155

Conservation of Marine Fish Genetic Resources—Present status and action needed	...	P. Das, P. C. Mahanta and D. Kapoor	...	159
The Role of Plankton Research in Fisheries Development	...	T. Balachandran and K. J. Peter	...	163
Studies on Upwelling at the Turn of This Century	...	A. V. S. Murty	...	173
Potential Applications of Satellite Remote Sensing Technique in Oceanography and Fisheries	...	P. V. R. Nair, V. K. Pillai and V. K. Balachandran	...	177
Validation of Landsat Thematic Mapper-Derived Phytoplankton Pigments through Synchronous Surface Measurements: Area off Calicut to Azhikal in the Arabian Sea	...	A. Narain and nine others	...	182
The Present Status and Future Prospects of Elasmobranch Fishery in India	...	P. Devadoss, M.D.K. Kuthalingam and R. Thiagarajan	...	188
Schooling Behaviour of Tunas in Lakshadweep Waters	...	Livingston	...	199
Present Status of Oil Sardine Fishery at Karwar	...	G. G. Annigeri	...	214
Problems of Identification among Species of <i>Sardinella</i>	...	K. P. Sivakumaran, M. Manickasunderam and V. Ramiyan	...	223
Present Status of Perch Fishery Resources in India and Its Prospects	...	H. Md Kasim, K.M.S. Ameer Hamsa and P. Sam Bennet	...	226
Population Dynamics of <i>Otolithes cuvieri</i> (Trewavas) off Bombay Waters	...	Sushant K. Chakraborty	...	238
Observations on Pelagic Fish Eggs and Larvae in the Coastal Waters of Tuticorin	...	Pon Siraimetan and R. Marichamy	...	245
Prospects and Problems of Management and Development of the Marine Molluscan Resources (Other than Cephalopods) in India	...	K. Alagarwami and M. M. Melyappan	...	260
The Morphology of the Alimentary Tract in Relation to Food of Platycephalids of Porto Novo Coast	...	R. Sivakumar and V. Ramiyan	...	262
An Assessment of Demersal Stocks in the Southwest Coast of India with Particular Reference to the Exploitable Resources in Outer Continental Shelf and Slope	...	D. Sudarsan, M. E. John and Antony Joseph	...	266
Trend of the Major Exploited Marine Fishery Resources of India during 1961-85	...	M. Srinath	...	272
Catch Rates and Catch Composition of Fish in Wadge Bank in Commercial Fishing	...	G. N. Mitra	...	284
Research in Marine Fisheries Management and Development—Capture and culture fisheries	...	P. S. B. R. James, K. C. George and Gopalakrishna Pillai	...	287

PREFACE

The national Symposium on 'Research and Development in Marine Fisheries', conducted at Mandapam Camp by CMFR Institute during 16-18 Sept. 1987, was part of the celebrations of the Fortieth anniversary of Independence of the country, which also marked forty years (1947-87) of dedicated and fruitful work in marine fisheries research and development in India. During these four decades a wealth of information has been collected and disseminated to the user sector. The attempts made with the specific purpose of understanding the dynamics of the marine fishery resources through biological and environmental studies coupled with the development of suitable mathematical models have been highlighted in the papers presented at the symposium. Further, the studies have led to an understanding of the distribution and abundance of commercially important marine fishery resources along with their spatial and temporal fluctuations and to monitor the impact of effort on the stocks exploited. This has provided the basis for rational and judicious exploitation of these renewable resources.

These resources, being dynamic, demand constant monitoring, which is systematically and scientifically done by various research institutes, state and central organizations and universities. In this context the key role played by CMFRI as the nodal organization in India for marine fisheries research needs no emphasis and it was fitting that the Symposium was held at Mandapam Camp, the headquarters of the Institute till 1970. This Symposium has provided an effective platform for interaction among various research workers, administrators and entrepreneurs, discussing the important aspects of R & D presented in the form of papers. Also, on this occasion, the Institute, for the first time, released State-wise appraisal reports based on analysis of data collected during the period 1975-84, which is a landmark in the history of marine fisheries research. This publication is the first part of papers presented at the Symposium, and the rest of the papers will be published in two other parts which are to follow.

It may not be out of place to mention the commendable work done in editing these papers by the Editorial Committee, first headed by Dr K. Alagarwami, the then Jt. Director, and then by Dr K. Alagaraja, Sr. Scientist. The Committee, in addition, had Sri M. S. Muthu, Dr. N. G. Menon and Dr. K. J. Mathew, Sr. Scientists. But for the efforts of all of them and the unstinted help received from the experts for screening, refereeing and editing the papers, this publication would not have been possible.

It is sincerely hoped that this publication would be made use of by scientists, administrators, entrepreneurs and industry to promote the marine fishery research and development in this country and would remain a valuable addition to the Institute's publications in this area.

P S B R JAMES
Director

National Symposium on Research and Development in Marine Fisheries

PAPERS PRESENTED

Technical Session I

NATIONAL FISHERY POLICY AND PLANNING

Paper 1

MARINE FISHERIES DEVELOPMENT - AN OUTLOOK FOR 21ST CENTURY AND KEY POLICY ISSUES

U. K. Srivastava

*Professor and Chairman, Research, Indian Institute of Management
Ahmedabad 380 015*

ABSTRACT

Marine fisheries will have to play a crucial role in augmenting supplies both in the domestic as well as export markets. Thrust of the development will be on deepsea and brackishwater resources. The exploitation of these resources, particularly deepsea, will require a rapid transition from charter of vessels to joint ventures and owned fleet with modern and sophisticated technology. Creation of sizeable owned fleet would require massive credit and fiscal support. This thrust for exploitation of deepsea resources can be sustained with concerted attempts to formulate and implement strategies for product development and marketing in both domestic as well as export markets. This will also require the attention to develop the necessary infrastructure to handle such vessels, onshore processing facilities, better management of fishing harbours, cold chain grid in the domestic markets, development of transit and terminal markets at wholesale and retail levels. Boatbuilding yards will have to take up new challenges. This also throws up challenges for net-marketing industry in this country. All these developments would also require massive efforts for training and development of manpower. This paper deals with all these areas in a systems framework and suggests appropriate policy support measures for strengthening various elements of the system.

The country has made remarkable progress in the sea food exports particularly in the recent years when the export has crossed Rs. 400 crores. In this sense the strategy for marine fisheries development in India may be considered successful. But a critical review of the performance indicates some of the weaknesses:

- 1) Shrimp has dominated the exports in all the years in value terms (Table-1). About 82% of the total sea food exports in 1986 were shrimps.
- 2) The exports have been basically confined to Japan and U. S. A. The other markets (wes-

tern Europe and elsewhere) have accounted for not more than 15% of the total value of the sea food exports.

- 3) The supplies to domestic market have been mainly as a residual factor from the mechanized boats (except from the motorized traditional crafts in Kerala and Gujarat). There has been a growing demand-supply gap for edible fish in the domestic market resulting in a more rapid rise in fish prices than all other commodities (Table-2). It may also be noted that although inland fish production was only one-third of the

TABLE 1.
Shrimp exports from India

Year		Total Exports	Quantity in tonnes		Value in Rs. in lakhs	
			Frozen Shrimp	Share Percentage		
1980	Q	74542	47762		64.07	
	V	21887.56	18336.61		83.78	
1981	Q	75375	54538		72.36	
	V	28671.28	24852.10		86.68	
1982	Q	75136	54625		72.70	
	V	34225.29	30097.83		87.94	
1983	Q	86169	53608		62.21	
	V	36232.31	31037.24		85.06	
1984	Q	89912	66194		61.39	
	V	38549.83	32728.48		84.90	
1985	Q	80588	49544		61.48	
	V	37566.83	31450.38		83.72	
1986	Q	89283	52113		58.39	
	V	46270.93	37997.89		82.12	

Source: Marine Products Export Development Authority, Cochin.

TABLE - 2
Wholesale price indices

Year	Price indices			
	All commodities	Food items	Meat	Fish
1953	46.7	43.9	38.3	27.0
1960	54.2	48.3	44.3	34.4
1965	71.2	70.0	74.0	84.0
1970	99.0	100.4	93.1	97.7
1975	175.3	170.0	202.5	157.9
1976	172.4	152.2	191.7	172.7
1977	185.4	170.8	215.9	192.4
1978	184.9	173.4	225.9	228.9
1979	206.0	181.3	255.8	253.4
1980	248.0	207.3	306.4	267.0
1981	278.4	230.3	330.4	346.6
1982	286.3	244.7	358.0	429.8
1983	308.1	275.7	376.5	451.6
1984	334.0	275.9	409.5	433.9
1985	353.3	294.6	489.9	484.6

Source: Economic Adviser, Ministry of Industry.

total production in India, it contributed 57% of the total edible domestic fish supplies.

4) In terms of deep sea resource exploitation, there has been very little effort to provide conducive infrastructure facilities at other than Visakhapatnam Fishing Harbour. Therefore deep sea fishing vessels belonging to Tamil Nadu, Gujarat, Kerala and Andhra Pradesh are all operating from Visakhapatnam only.

5) Introduction of deep sea trawlers has also been geared towards shrimp resources primarily operating in the northern Bay of Bengal with Visakhapatnam as base

6) The catches per unit effort and per vessel have gone down in recent years, yet the introduction of trawlers for shrimping has continued because the average unit value realisation of shrimp has been going up and it stood at Rs. 72.86 per kg in the year 1986 as compared to Rs. 33.90 in 1976. This increase in unit value realisation has taken place despite the fact that our export of shrimps has continued to be mostly in frozen block form.

This paper briefly reviews the strategy of marine fisheries development in a systems

framework and indicates the major changes in the exploitation of deep sea and brackish water resources for meeting the projected export level of Rs. 700 crores by 1990 and Rs. 1200 crores by the year 2000 A. D., and also the domestic supplies to meet the growing demand. Before the review of the strategy for marine fisheries development, a systems perspective for marine and brackish water fisheries is presented

I. A SYSTEM FRAMEWORK OF MARINE AND BRACKISH WATER FISHERIES

The total fisheries system can be broadly classified into:

- i) Resource sub-system
- ii) Input sub-system
- iii) Processing sub-system, and
- iv) Marketing sub-system.

All the sub-systems have interlinkages with each other. Unless all the sub-systems are developed properly, nothing can be achieved because they all are interdependent. The linkage

of major sub-systems in the industry are presented in Fig. 1 and resource-wise linkages are given in Figures 2, 3 and 4.

A. RESOURCE SUB-SYSTEM

The resource sub-system defines the limits of growth and where actual fishing operation takes place. The resources can be broadly classified into three categories:

- a) Inshore resources,
- b) Off-shore resources, and
- c) Brackish water resources.

Inshore Resources

The Indian inshore region (upto 50 metres depth) is highly exploited and sometimes over exploited also, because the majority of fishermen operate country crafts in areas very near to shore. Therefore, the major thrust of the development is to be off-shore resources especially deep sea resources and brackish water resources.

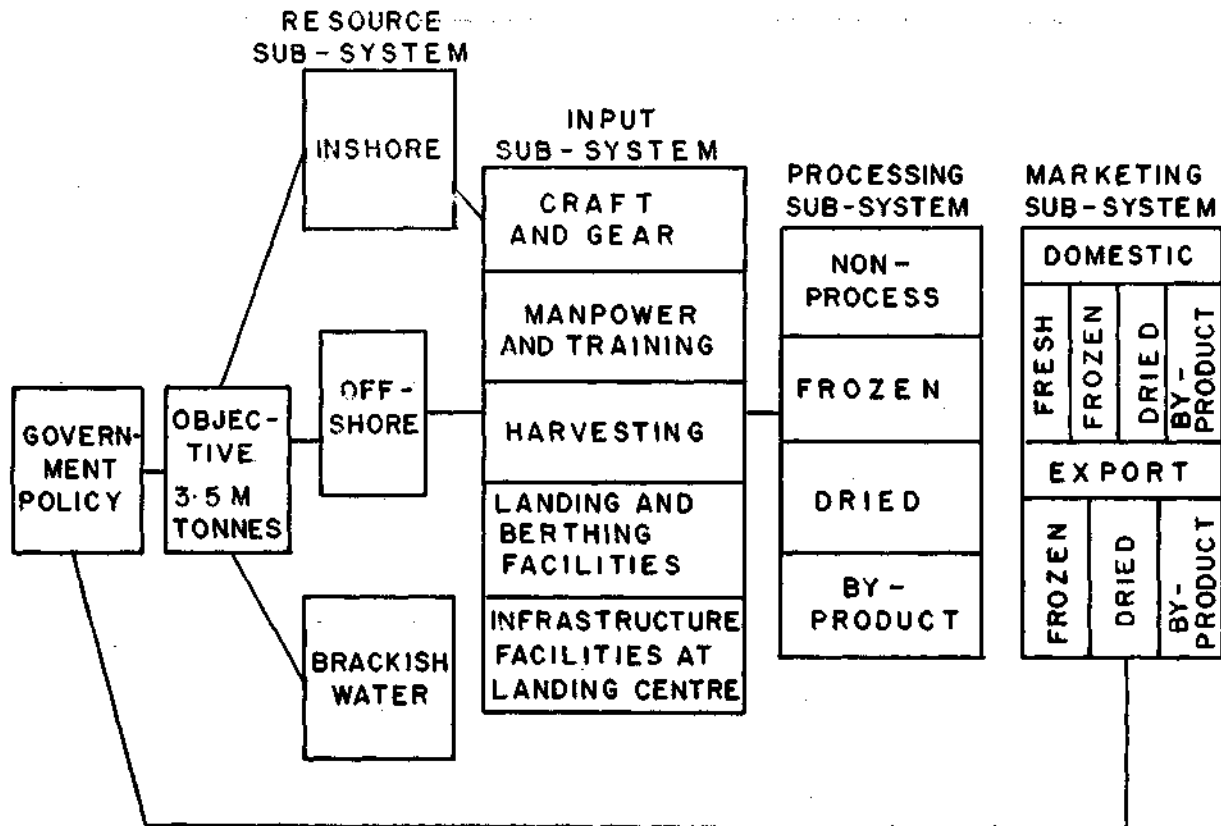

Fig 1

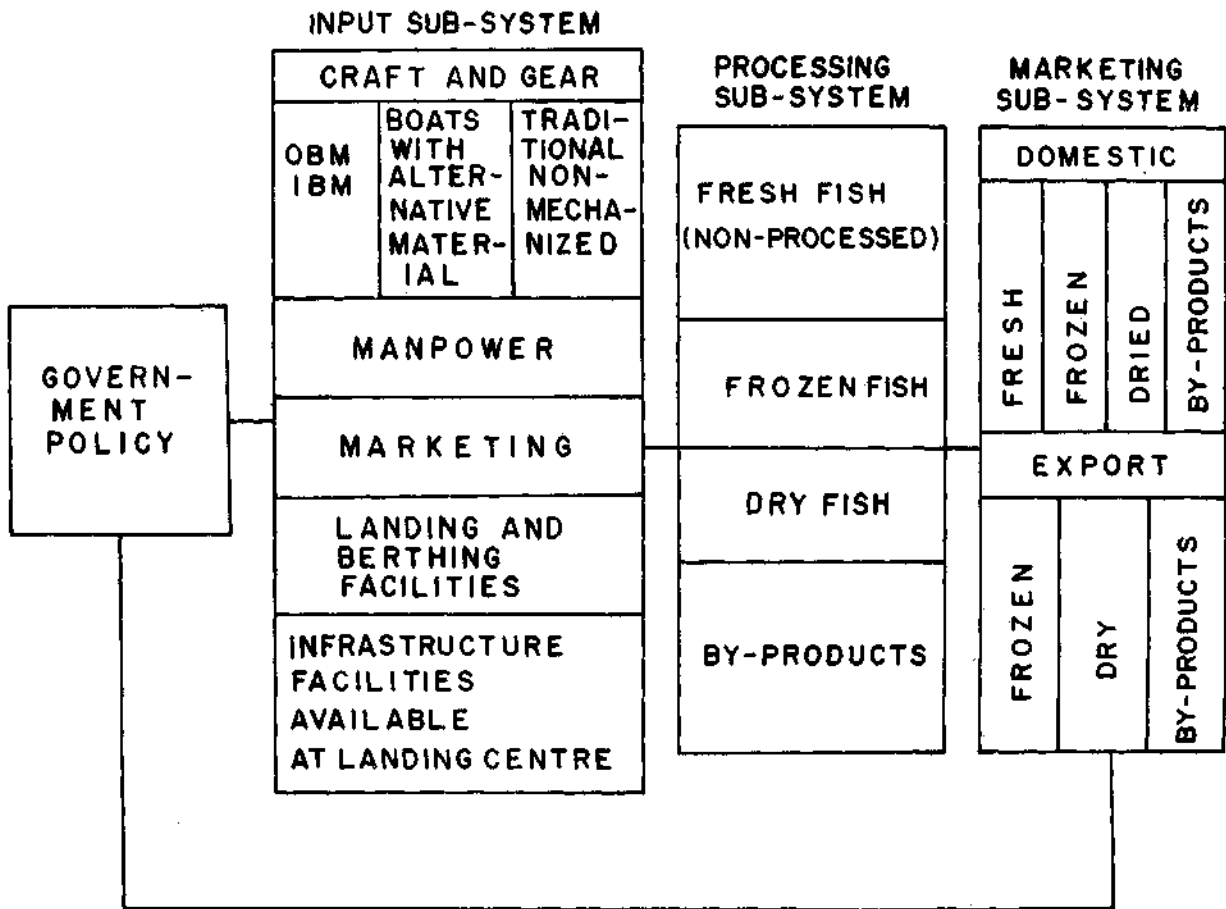

Fig. 2

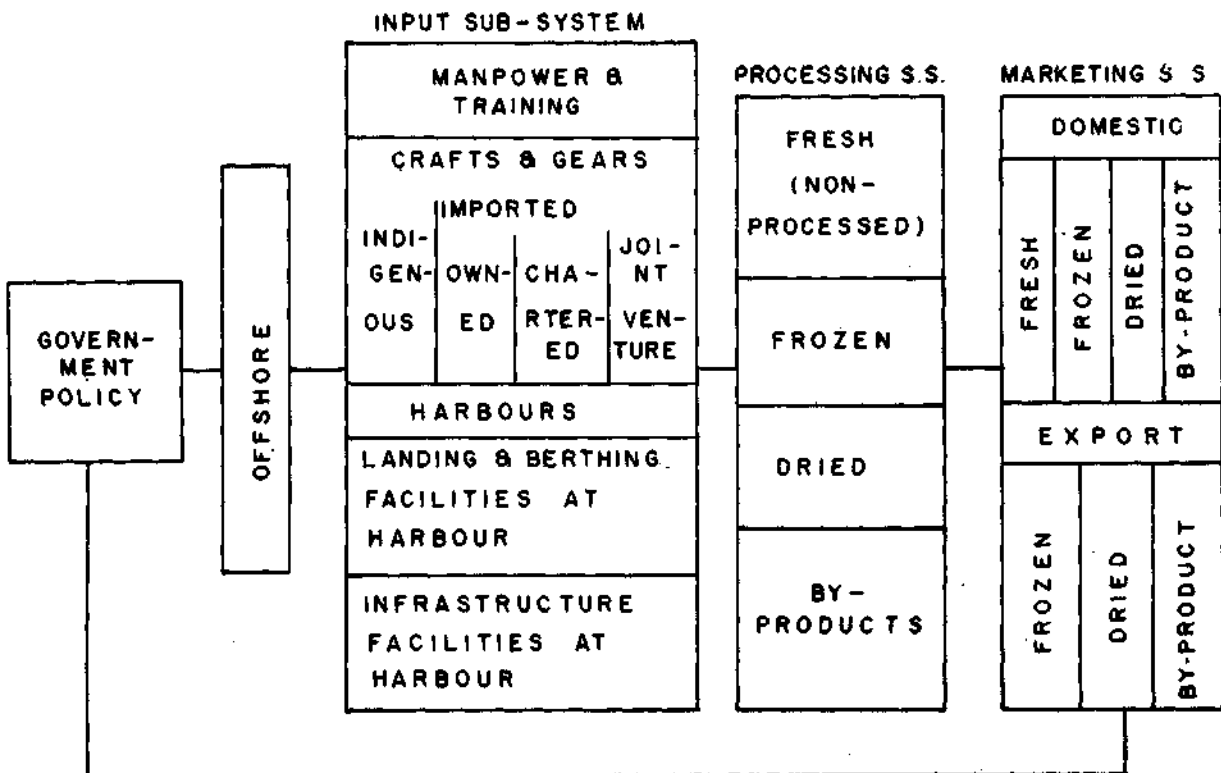

Fig. 3

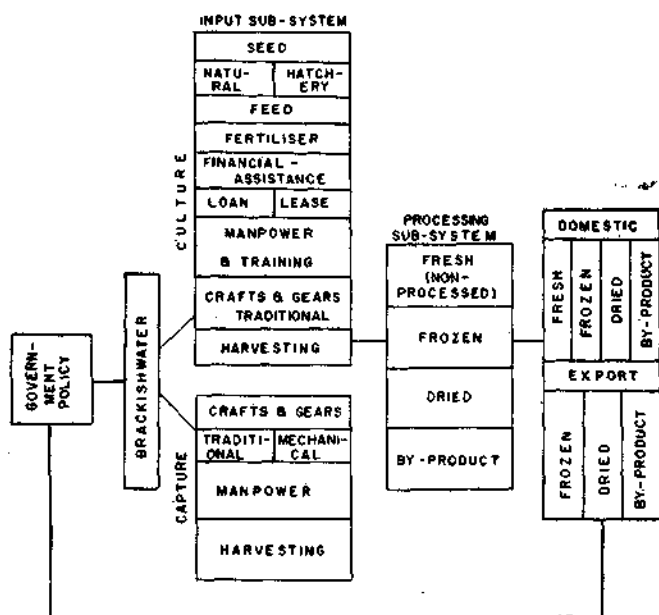

Fig. 4

Off-shore Resources

The declaration of EEZ has opened up new potentials for fisheries development. The deep sea zone (beyond 50 metres depth) contains 38.3% of total marine potential, while 11.1% of total potential is in the depth beyond 200 metres. It is estimated that our EEZ resources are capable of producing 4.5 million tonnes of fish and prawn, if developed and exploited properly. However, the contribution of the deep sea resources to present catch is hardly one percent.

Brackish water Resources

The importances of brackish water culture lies in its capacity to supply of exportable prawns. Of the total 182,000 tonnes of prawn production in India, the share of brackish water was about 30%. According to IIMA study, the estimated culturable area of brackish water in India is about 0.95 million hectares. The area utilized so far is not more than 3% of the potential which accounted production of about 10,000 tonnes.

B. INPUT SUB-SYSTEM

The importance of the input sub-system lies in involvement of its interlinked sub-systems in increasing the production. It covers the components from actual fishing to fish landing.

Inshore Resources

Nearly two lakh traditional crafts and more than 16,000 mechanized crafts have been operating in inshore areas. The mechanized craft operating are mainly the small size ranging from 9 to 12 metres and the majority of them are outboard motors (OBM) or inboard engines (IBE) type. However, the operation of these mechanized boats is becoming non-viable due to hike in fuel prices and cost of its spare parts as well as cost of wood itself. To overcome the increased cost of wood, efforts are being made to construct boat from materials like FRP/Ferro Cement which are cheaper in cost compared to wood, better in strength and easy to handle.

It has been estimated that introduction of 3,500 improved traditional fishing crafts in FRP with outboard drives and 5,000 mechanized boats in FRP/Ferro Cement for fishing in different regions of the country would be needed for exploitation of our marine resources in coming decades.

Off-shore Resources

For the development of off-shore resources requires big mechanized boats (17 metres and above) with onboard freezing facilities. Creation of sizeable owned fleet requires massive credit and fiscal support. Credit is an important input in case of deep sea exploitation.

Brackish water Resources

Development of brackish water ponds for fish/prawn culture is highly capital and technology intensive operation. Prawn seed is the most critical input for brackish water culture development. One should not rely on natural seed resources. Fertilizer and feed are the other important inputs for brackish water culture. The culture of prawn requires knowledge of their nutrient requirements in order to provide adequate food for their growth and survival.

Most of the brackish water areas suitable for culture are owned by government agencies. Looking at the high investment and the risk involved in the business, it has been suggested that these lands be leased to fishermen on long term basis, which would be helpful in obtaining credit from the financial institutions and facilitate improvements of pond for intensive production.

Infrastructure for Landing and Berthing

Fishing harbours or fish landing centres are an important link between freshness of fishing operation and delivery of fishes to consumers. Establishment of fishing harbours with facilities like landing quay, berthing jetty, fuel, fresh water, etc. are essential. Boat and net repairing facilities are essential at fishing harbours. Facilities like cold storage, approach roads and transportation are prime requirements at landing centres. At every fishing port, auction and pecking hall is required and sufficient land for processors needs be earmarked.

Manpower Training and Education

When deep sea and brackish water resources are to be exploited, the need for training and education for the complex operation has become more intensive. In case of deep sea operations, the education of fishing grounds and fisheries science are needed along with the training of operations of deep sea craft and gears, whereas in case of brackish water culture the system is totally different. Prawn culture in brackish water fields has emerged as a multidisciplinary science, which involves many aspects from fishery biology to engineering and processing.

C. PROCESSING SUB-SYSTEM

Fish is of highly perishable nature, the fresh fish can't be stored overnight in normal temperature. Hence, fish has to be either kept in ice or chilled store to keep its freshness until it is consumed or processed. Ice is used at different stages of operation. Hence, the country needs to have sufficient number of ice plants and cold storage in order to extend the shelf-life of fish and avoid wastage. Development of edible products from by-catch is a prime area in the market development.

D. MARKETING SUB-SYSTEM

Fish marketing can be broadly classified into two categories: (a) Domestic market and (b) Export market.

In the domestic market fish is mainly consumed in fresh form. Only due to non-availability of fresh fish the consumer is forced to have fish in other form viz. dry and by-products. In the domestic market the movement

of fresh fish is arrested by inadequacy of proper marketing infrastructure. In the domestic fish market there are many traders performing different functions or multiple functions. The share of fishermen in the consumer rupee depends on the number of intermediaries and the distance moved between the landing centre and consumer centre. The standardization in quality and weighing will improve the fishermen's realization which otherwise leave both fishermen and consumer at the mercy of traders. Licensing traders is also helpful to regulate the market.

Another important aspect in the marketing system is the involvement of cooperatives in the fish market which is considered to be a suitable organization for increasing fishermen's realisation and looking after his daily needs. The cooperatives have to provide an integrated service covering the supply of input, working capital requirements and marketing as the traders have been doing.

Export market development provides the valuable foreign exchange earnings. This sub-system consists of all the infrastructure which prepares products or facilitates for export markets. This infrastructure includes organizations and processing units. The strength of the export marketing sub-system is evaluated on how diversified are the products and markets.

II. STRATEGY FOR MARINE FISHERIES DEVELOPMENT IN INDIA

INSHORE RESOURCES

A major impetus of mechanization of fishing crafts came from export potential for shrimps. Therefore, since the inception of planned development, the mechanization of fishing crafts has been geared towards enhancing the power of boats to haul the trawl nets to catch the shrimp resources.

Most of mechanized boats operate in inshore waters and edible table fish supplies to domestic market account for only 15 to 20% of the catches. Despite the mechanization, traditional boats still account for 65% of the total catches. It is in the Seventh Plan that

Illustrative Financial Analysis of a 23.85 metres Shrimp Trawler Operating from Vishagapatnam

	Rs. in lakhs
1. Capital Cost:	
— Cost of trawler inclusive of CST @ 4 %	70.14
— Cost of outrigger, nets and accessories	1.10
— Cost of providing shore facilities	1.00
— Working capital requirements	2.48
Total including contingency @ 5%)	78.49
2. Annual Operating Expenditure	23.16
3. Total Revenues (Sum of flows for 20 years)	298.09
4. Net Revenues (")	221.63 + 7.03 (salvage value)
5. IRR	20.54%

- Notes:* 1. 8 voyages (average of 25 days duration each).
2. Catch per voyage:

PRAWNS			
1. Tiger	400	200	0.80
2. White	800	160	1.28
3. Brown	2800	85	2.38
	<u>4000</u>		
FISH			
1. Quality Fishes	5000	7	0.35
2. Misc. Fishes	1000	3	0.03
		Total	4.84
Total income (8 voyages each)			38.72

Source: NABARD, Bombay.

emphasis has been laid on motorization of the traditional crafts (mainly dugout canoes and plank built boats) with a view to enhance the edible fish supplies from the inshore regions and improve the income level of traditional fishermen.

DEEP-SEA RESOURCES

Our long coastal line of about 6,500 kilometres, having an Exclusive Economic Zone of about 2 million square kms, has most of the vessels which are mainly engaged only in shrimping operations. A very rich potential of other species of fish to an extent of around 2.5 million tonnes are available in the tropical continental shelf around India, which are to be

harvested annually. In view of the potential of the marine fishing industry, the Seventh Plan proposes to induce 500 large fishing vessels of OAL ranging between 24 metres and 60 metres by 1990. Presently most of these vessels work on the following kind of typical financial calculations:

PROCESSING SUB-SYSTEM

Since most of the trawlers are geared to shrimp resources the processing has been also geared to make it into frozen block form. It is known that there could be approximately 25% higher unit value realisation by value addition if we can convert our shrimp in value added form, like individually quick frozen (IQF shrimp).

Similarly there are large by-catches of fish but no effort has been made to convert it into edible products for the domestic market and exports. Even there have been instances when large trawlers attempted to discard into sea anything other than shrimp. No specialised fishery for exploitation of squids, cuttle fish, tuna and lobsters has been developed.

No thought has been given about the resource depletion effort of the continued introduction of shrimp trawlers in the same north Bay of Bengal fishing grounds. The preliminary evidence indicated that the catch per boat is declining in this area.

BRACKISH WATER RESOURCES

It has been estimated that 1.4 million hectares of brackish water area (with 0.9 million ha. of culturable area) is available for exploitation for shrimp and other fish production. This area is spread all over our coastal districts largely in the states of Andhra Pradesh, Karnataka, Kerala, Maharashtra, Orissa and West Bengal and has so far been practically lying unutilized. The volume of exports of shrimp in future would largely depend upon the exploitation of this brackish water area. Even one lakh hectares of area with one tonne potential yield 100,000 tonnes of exportable prawns. Yields in Taiwan, Equador and Panama have crossed 20 tonnes per hectare. Thus the potential for us to augment the supply of shrimp from brackish water supply is immense.

III. OUTLOOK AT THE TURN OF THE CENTURY AND POLICY IMPERATIVES

It is now becoming clear that production from inshore resources and shrimp landing from capture fisheries can't be main stay for marine fisheries growth in the 21st century. The marine fisheries growth for export as well as domestic market would have to come from brackish water culture for shrimp and deep sea fisheries for non-shrimp resources. The elements of strategy to promote the new resources of growth should be again seen in the systems frame-work as indicated above. It is briefly summarised below:

INPUT SUB-SYSTEM

Deep Sea: Perhaps we will have to put a limit to the introduction of shrimp based trawlers in the name of deep sea resources exploitation. Instead we will have to encourage larger but specialized vessel for non-shrimp resources. These vessels again would require different types of gear and manpower training that has been traditionally imparted. Similarly the landing and berthing facilities for such vessels would have to be diversified at several places like Andamans and Lakshadweep islands on the pattern of Visakhapatnam. These fishing harbours would have to be equipped with modern landing and berthing and processing facilities, which make it attractive for large vessels to land their catches for processing and exports from these harbours.

Brackish Water: In case of brackish water the biggest problem is the availability of long term leasing systems along with feed seed and manpower training. The perpetual conflict between growth and equity observed in recent years in case of government policy, research at technical institute and funding institutions need to be resolved. We would have to promote intensive culture of prawns on the pattern of our competitors and the equity objectives will have to be met at best through the organizational mechanisms (for example, through industrial state of brackish water fish farmers where farmers with limited means and financial background can also participate in the highly capital intensive culture operation).

PROCESSING SUB-SYSTEM

Deep sea: As we encourage more trawlers for non-shrimp catch, it will be necessary to augment the processing sub-system not only for exportable variety like tuna and cuttlefish but also edible products out of by-catch for the domestic market. The thrust on development of deep sea resources calls for product development out of unconventional varieties. The product development should aim at:

- i) making convenience food out of fish available for direct consumption with a large shelflife, and

- ii) converting low value fish into high value products with consumer acceptance.

It is in this area that a close coordination between the Ministry of Agriculture, Ministries of Commerce and Industry have to be effected. Although technology exists at experimental stage (for example, at Integrated Fisheries Project, Cochin) the role of private sector units involved in food processing will be crucial for the by-catch processing. In this context the emerging trend towards processed food industry is notable and these units should be encouraged to take up fish processing for domestic markets also.

In case of shrimp, the policy support should be moved to IQF, so that unit value realisation can be further increased. Funding institutions (Commercial Banks, NABARD, IDBI and ICICI which is going to operate shipping development fund) need to reorient themselves for financing various elements of the system.

Brackish water: In case of brackish water shrimp production we may have to encourage the well known processing houses to open their procurement centres at the pond site. The remaining task can be handled by the processing facilities development for the landings from capture system.

MARKETING

Deep sea catches: As indicated above 82% of the export had been mainly of shrimp. There has been traditionally established markets. Now with the emergence of Taiwan and Ecuador for the supply of shrimp, even in case of shrimp we will have to go for more aggressive marketing efforts and enforce more strengthened quality control measures. In case of other varieties of fish we have not learned the process of international marketing mainly because of our pre-occupation with chartering of vessels where the foreign charter party undertakes a function of marketing of all the catches. We shall now have to make vigorous efforts to promote joint ventures and own fleet and this will entail international marketing effort of different order not experienced so far.

In case of domestic markets several steps will have to be taken to augment the supply from marine resources. This include develop-

ment of infrastructure of fish market, cold chain grips to move the fish and products from by-catches to far away demand centres in the country and making the quality fish available to the consumers at convenient places. The domestic market will have to act as a cushion for fluctuations in the international markets. The strategy of treating the domestic market as a residual would have to change and this will make the deep sea trawlers with non-shrimp resources also financially viable.

Brackish water production: Exploitation of brackish water resources would yield shrimp for export and some fish for domestic market. While shrimp has to be processed and marketed as in the case of capture fisheries, the fish production from brackish water resources may have to process to enhance the shelf-life and transported to higher demand centres. For example, in Philippines,, milk fish is smoked and sold to the consumers all over the place. In case of some other fishes market development effort would be necessary.

While in the past, major impetus for marine fisheries development came from growing demand and rapid rise in the unit value realization from shrimp in the international markets, the strategy by the turn of this century will have to be diverted towards the culture of prawns and also processing as exports of other fish for export market.

Since there was a pre-occupation with the export market no special attention was made for the development of domestic market. With the result, per capita consumption of fish in our country has been around 3.5 kg and there has been rapid increase in the prices of edible varieties. There is an urgent need to augment the supply in domestic market from marine sources and this requires strengthening of inshore catches from traditional crafts, motorized traditional crafts and small trawlers; in addition there is a need for processing and marketing of edible products from by-catch on a much larger commercial scale.

ACKNOWLEDGEMENT

The author gratefully acknowledges the research help from Mr. G. Ramchandran Nair, Research Assistant, JJM Ahmedabad.

GROWTH PROFILE OF MARINE FISHERIES IN INDIA

P.S.B.R. James

Central Marine Fisheries Research Institute, Cochin-682 031

ABSTRACT

An attempt is made in this paper to outline the growth and changes that have taken place in the marine fisheries of India over the past 4 decades. The trends in marine fish landings, the progressive changes that have taken place in the craft and gear employed to catch the fish, the progress made by the fish-processing and marketing industry, including the phenomenal growth of the export of marine products, are reviewed.

The rapid progress achieved in important areas of marine fisheries research in the post-Independence era and the areas in which more research is needed in the coming years are discussed. Education and training programmes aimed at providing the trained manpower to implement the various developmental programmes connected with the growth of the marine fishing industry are also outlined and the need for strengthening these programmes is pointed out.

The growth in the fishermen population, the mechanisation of the indigenous craft, the introduction of the mechanised fishing vessels such as trawlers, purse seiners and gill netters into the marine fishery, the advent of large trawlers on the northeast coast of India and the effect of all these developments on the traditional fishermen are discussed. The attempts at promoting joint ventures and chartering of foreign vessels are analysed with respect to advantages and disadvantages of such endeavours. The growth in the financial outlay during the successive five-year plans at the Central and State levels and its impact on the development of the marine fishing sector are briefly elucidated.

The socio-economic consequences of all these developments, the new problems that have been thrown up by the progress and growth of the marine fishing sector and the strategies for solving some of these problems are discussed. For the balanced growth of the marine fisheries in India, an integrated approach is needed involving all the factors, scientific, technological, administrative and social, that have a bearing on the capture, processing and utilization of the marine fishery resources.

In the pre Independence era marine fisheries in India was a neglected subject or as we euphemistically call it a "deferred subject" as far as the British Administration was concerned. Apart from enacting the Indian Fisheries Act in 1897, which gave full powers to the provincial Governments to frame and implement regulatory measures in fisheries, little attention was paid to the development of the marine fisheries sector.

But due to the interest taken by the officers of the East India Company beginning with Russel and Hamilton Buchanan and followed by several others like Francis Day, a Veterinary Surgeon who subsequently rose to the position of the Inspector General of Fisheries the officers of the Marine Survey of India such as Seymour Sewell, Alcock and Anderson and later the stalwarts of the Zoological Survey of India, Stanley Kemp and Hora, a wealth of valuable information on the marine fauna of India was collected. In the early part of the

20th century the dedicated work done by Nicholson and James Hornell in the Madras Fisheries Department laid the foundation for the development of marine fishery in India.

The problem of supplying adequate quantities of fish to the Allied Forces stationed in India during the Second World War forcefully brought home to the British Administration the woefully backward condition of fisheries in India. In January 1945 the Fish Sub Committee of Policy Committee No 5 on Agriculture, Forestry and Fisheries under the guidance of Bains Prasad who had become the Fishery Development Adviser to the Govt. of India, recommended the establishment of a Central Fisheries Research Institute and also suggested other measures for development of fisheries in the country. This historic document brought fisheries within the orbit of concurrent subjects.

This led to the establishment of the Central Marine Fisheries Research Institute in Madras

and the Central Inland Fisheries Research Institute at Barrackpore in 1947, the Deep Sea Fishing station at Bombay in 1948 and later the Central Institute of Fisheries Technology (1957) to catalyse the development of fisheries in India. The State Fisheries Departments were also provided with grants for some projects. The Five Year Plans initiated by the Govt. of India for the planned progress of the country set apart specified amounts for the development of Fisheries in India, for fisheries research, modernization of fishing craft and gear, development of infrastructure facilities such as fishing harbours, cold storages, ice plants, coastal roads and transport facilities, and for the social uplift of the fishermen community.

The plan outlays for fisheries development in the seven Five Year Plans are given below:

	Crores of Rupees	Share in total outlay (%)
First Plan	5	0.26
Second Plan	12	0.27
Third Plan	28	0.38
Fourth Plan	83	0.58
Fifth Plan	151	0.38
Sixth Plan	371	0.38
Seventh Plan	499	0.28

Although there has been a substantial increase in the financial outlays for fisheries in successive plan periods the percentage of funds allotted to fisheries fluctuated from a meagre 0.26% to 0.38% of the total outlay except for the 4th plan when the share of fisheries was 0.58%. Although these funds are woefully inadequate to meet the needs of the fisheries sector, the planning has led to some tangible progress in the field of fisheries over the years.

The major developmental activities that were taken up during each Five year Plan are outlined below:

1st and 2nd Five year Plans

Emphasis on mechanisation of indigenous crafts, introduction of mechanised fishing boats improvements in fishing gear, establishment of infrastructure facilities such as processing plants, cold storages and landing centres.

3rd Plan

Above programmes continued with greater emphasis on introduction of mechanised boats and adoption of synthetic materials for fishing gear. Establishment of facilities for marketing. Exploratory fishing intensified. Expansion of export trade. Programmes for manpower training intensified.

4th Plan

Beginning made in deep-sea fishing through import of trawlers as well as their indigenous construction. Export promotion intensified. Construction of mechanised boats intensified. Preinvestment survey for construction of fishing harbours taken up. Intensification of exploratory surveys.

5th Plan

EFP strengthened for deep sea exploration. Diversification of fishery products. Construction of mechanised boats. Provision of infrastructure facilities for larger vessels. Development of culture technologies for prawns, fish, molluscs and seaweeds. Development of ancillary industries such as boat building, net making etc. Development of brackishwater farms in maritime States. Socio-economic uplift of fishermen.

6th Plan

Intensification of efforts to stimulate brackishwater prawn farming in the States. Funds provided for building large trawlers in the country or for importing them. Building up of infrastructure in fishing harbours to facilitate operation of large trawlers. Export promotion intensified. Exploratory survey of deeper areas for oceanic tunas and deep sea fish. Motorisation of country craft with outboard motors. Socio-economic uplift of fishermen.

7th Plan

Promotion of prawn farming and hatcheries. Development of deep-sea fishing fleet through imports and local construction of big trawlers. Strengthening of domestic marketing of fish. Diversification of fish products. Motorisation of country craft.

This paper outlines the growth profiles in the field of marine fisheries during the past 4 decades.

MARINE FISH PRODUCTION

It was estimated that the total marine fish catch in 1947-48 was about 3.73 lakh tonnes (Anon, 1951). With the establishment of the Central Marine Fisheries Research Institute, the collection of statistics of marine fish landings on an all India basis was standardized and reliable production figures are available from 1951 onwards (Table 1). It has increased from 3.73 lakh tonnes during the Pre-Independence period to 17.23 lakh tonnes during 1986. Over all, there has been an increasing trend in the total production of marine fish as could be seen from Table 1.

TABLE 1
Annual marine fish landings (in lakh tonnes)
in India from 1951 to 1986

Year	Landings	Year	Landings
1951	5.34	1969	9.14
1952	5.28	1970	10.86
1953	5.81	1971	11.61
1954	5.88	1972	9.80
1955	5.96	1973	12.20
1956	7.19	1974	12.18
1957	8.76	1975	14.23
1958	7.56	1976	13.53
1959	5.85	1977	12.60
1960	8.80	1978	14.04
1961	6.84	1976	13.88
1962	6.44	1980	12.50
1963	6.55	1981	13.78
1964	8.60	1982	14.21
1965	8.33	1983	15.48
1966	8.90	1984	16.31
1967	8.63	1985	15.35
1968	9.03	1986	17.23

Source : CMFRI

The plan-wise trend in marine fish production is as follows:

Plan period	Average annual production (lakh tonnes)	Growth rate between the Five year plan periods	annual av. growth rate
First Plan	5.84		
Second Plan	7.60	30.1%	5.4%
Third Plan	7.56	-0.05%	-0.01%
Fourth Plan	11.03	45.9%	7.8%
Fifth Plan	13.48	22.2%	4.1%
Sixth Plan	14.74	9.3%	1.8%

After the initial spurt in the catches during the first two years of the Second Plan period, the marine fish production stagnated during the major part of the 2nd and 3rd Plan periods and began to increase again towards the end of the 3rd Plan period. Interestingly, the sudden increase in marine catch during the 4th Plan period coincides with the increased financial outlay for fisheries (0.58%) during the 4th five year Plan. The growth rate in production between the plan periods reached a peak during the 4th plan period and then slowed down during the 5th and 6th plan period.

The sudden increase in marine fish production during the 4th plan period is probably due to the introduction of small mechanised boats and opening up of newly discovered fishing grounds along the Indian coast as a result of the surveys conducted by the Govt. of India vessels and the vessels belonging to the Indo-Norwegian project. The share of the total marine catch by the mechanised fishing vessels over the years is given below:

Year	Share of mechanised boats in total marine catch	Year	Share of mechanised boats in total marine catch
1969	20.0%	1978	53.0%
1970	22.0%	1979	53.7%
1971	21.0%	1980	59.6%
1972	38.0%	1981	60.9%
1973	37.0%	1982	63.9%
1974	36.0%	1983	62.4%
1975	39.0%	1984	63.9%
1976	42.0%	1985	72.9%
1977	49.9%	1985-86	75.0%

Source: CMFRI

The share of the mechanised fishing boats (Motorised indigenous crafts are also included) has increased from 20% in 1969 to 75% in 1985-86. This is closely related to another trend noticed in the composition of the marine catches in India over the same period. The pelagic fish which form the major part of the catch of indigenous craft contributed 65% of the total marine fish landings in 1969 while they formed only 51.4% of the total landings during 1985-86. In other words the contribution of the demersal fish which form the dominant component in the catch of mechanised vessels has increased from 35% in 1969 to about 49% in 1985-86. The significant impact of the mechanisation programme on the marine fish catch is evident from these trends.

MEANS OF PRODUCTION

The growth that has taken place in the fishermen population and the fishing craft and gear during the recent years is outlined here. The earliest estimate of the fishermen population of India is given for 1931 by Anon (1951). The total fishermen population (marine as well as inland) was 13,35,565 out of which 4,30,633 were active fishermen. The number of marine fishermen is not given separately. However, the Fisheries Sub-committee (1945) had noted that there was a marked decrease in the number of active fishermen particularly in the maritime areas due to the poor returns that the fishermen were getting and the consequent mass enrollment of fishermen in the fighting forces during the Second World war (Anon, 1951). The Central Marine Fisheries Research Institute has conducted frame surveys and census of fishermen villages during 1961-62, 1973-77 and 1980. The summary of the data collected during these surveys is given below:

	1961-62	1973-77	1980
No. of fishing villages	1797	1913	2408
Fishermen population	9,59,937	14,35,158	20,96,314
Active fishermen	2,29,364	3,22,532	4,74,731
No. of indigenous boats	90,424	1,06,480	1,40,833
No. of mechanised boats	nil	8,086	19,013

There has been a 118% increase in fishermen population from 1961-62 to 1980 while the increase in active fishermen was 108% during

the same period and the number of indigenous crafts increased by 55.7%.

The various types of indigenous boats at the time of our independence was estimated as 69,897 (Anon, 1951). This estimate is compared with the number of indigenous craft estimated during the 1980 survey of the CMFRI below:

	1947	1980
Plank built boats	3,485	39,147
Dug-out canoes	36,317	26,442
Catamarans	23,852	73,886
Masula type boats	6,243	2,150
Total	69,897	1,40,833

While the number of indigenous boats has doubled during the period, there has been a reduction in the number of dug-out canoes (by 25.5%) and masula-type boats (by 65.6%). There has been a 10 fold increase in the number of plank built boats and a 3 fold increase in the number of catamarans. The reduction in the number of dug-out canoes may be due to the non-availability of large trees which were traditionally used for constructing the dug-out canoes. The masula-type boats which were used for operating the large shore seines such as *Kara valai* in Tamil Nadu, *Alivi vala* and *Pedha vala* in Andhra Pradesh and *rampani* in Karnataka and which needed a large number of men to operate, have become reduced in number perhaps because it has become uneconomical to operate these labour intensive gear.

Although experimental trawling with small mechanised boats (10.97 m OAL) were carried out even during 1954-59 by the Indo-Norwegian project, along the S. W. coast in shallow waters, commercial trawlings with small mechanised vessels became popular only in the later half of the sixties.

They were mostly 9.14 m to 9.75 m in OAL. The smaller ones popularly called Pablo boats which was originally designed by Mr. Illugasson, FAO Expert to Tamil Nadu Govt. were used for operating drift gill nets and also for hand operated trawl-nets. The larger boats were fitted with trawl winches. Purse seiners were introduced in Karnataka and Goa on a commercial scale in 1976-77 and later in Kerala. One

of the earliest indigenous boats to be mechanised were the plank built boats of Maharashtra, Gujarat and Tuticorin. In recent years the dug-out canoes and catamarans of Kerala are being motorised by fixing outboard motors. According to the 1980 survey conducted by the CMFRI the number of mechanised boats under each category were as follows:

Trawlers	11,316
Gill netters	3,931
Dol netters	2,895
Purse seiners	428
Others	217
Total	18,790

According to the latest estimates there are about 23,000 mechanised boats in the country. (This includes motorised indigenous crafts).

Recently the B.O.B.P. has developed and tested beach landing crafts constructed of fibre glass for operating from the surf beaten coasts of Tamil Nadu and Andhra Pradesh. During the Seventh Five Year Plan it is proposed to introduce on an All India basis 2000 beach landing crafts and motorise 8000 indigenous crafts to increase fish production from the inshore waters.

SURVEY OF OFFSHORE AND DEEP SEA FISHING GROUNDS

Simultaneously with these developments which were taking place mainly in the inshore waters, many agencies have been trying to explore the possibility of extending the fishing operations to deeper areas not being exploited by the indigenous crafts. Even before Independence, the provincial Governments of Bengal, Madras and Bombay tried to fish upto 100 fathom depth with steam powered vessels, such as *Golden Crown* (1908) in the northern Bay of Bengal, *Lady Goschen* (1927-30) in the S. E. and S. W. coasts and William Carrick (1921-22) in the N. W. coast. Apart from indicating the presence of some potential fishing grounds these operations were not successful. It was only after the establishment of the Deep Sea Fishing Station (DSFS) by the Govt. of India (GOI) at Bombay in 1946 that exploration for new fishing grounds in Indian

waters really got under way. The GOI soon established offshore fishing bases at Cochin, Mangalore and Veraval on the west coast and at Tuticorin, Madras and Visakhapatnam on the east coast and also a base at Port Blair in the Andaman Islands and the whole programme was renamed as Exploratory Fisheries Project (EFP) in 1974 and later as Fishery Survey of India (FSI) in 1983. Starting with the steam trawler *Meena* in January 1948, followed by Danish cutters M. T. Ashok and M. T. Pratap (250 H. P.) and a host of other TCM aid vessels of smaller and larger sizes upto 1969, this exploratory programme in close collaboration with the scientists of the CMFRI who participated in some of the cruises, brought out the results of these surveys in a series of publications (CMFRI, 1954; Jayaraman *et al.*, 1959; Nagabhushanam *et al.*, 1964; Rao *et al.*, 1968; Rao and Dorairaj, 1973; Pai and Mahadevan Pillai, 1973; Sekharan *et al.*, 1973, Kuthalingam *et al.*, 1973 and Rao, 1973). Between 1970 and 1980 the EFP acquired 20 numbers of identical steel trawlers of 17.5 m OAL and organised a comprehensive survey of the demersal resources of the entire Indian coast upto a depth of 7 m from 12 bases. This well planned, round the year coverage of all the areas and depths upto 70m has yielded valuable information about the demersal resources of our coastal waters (Joseph, 1980).

With the declaration of EEZ in 1976 the Government of India keenly felt the need for collecting data on deep sea resources beyond the 70 m depth and, therefore, chartered a 69 m Polish factory trawler M. T. MURAENA which surveyed the north-west coast between latitude 15°-23° upto a depth of 200 fathom. This vessel used both bottom trawls and pelagic trawls and discovered the existence of vast shoals of horse mackerel, ribbon fish, cat fish, pomfrets and carangids in the region. In fact the pelagic trawling by M. T. MURAENA yielded better results than bottom trawling (Anon, 1979; Bapat *et al.*, 1982). From 1979 to 1986 the FSI has been acquiring larger survey vessels (31.5 m to 42.5 m) for conducting bottom trawling, pelagic trawling and long-lining in the deeper areas (70-500 m) of our EEZ on the east and west coast. A wealth of information on the availability of deep sea

demersal fishes and tunas has been collected by these surveys. (Philip *et al.*, 1984; Joseph and John, 1986; Joseph, 1986; Sivaprakasam, 1987 and FSI Bulletin No. 13). It was observed that the northern latitudes of Gujarat, Maharashtra, West Bengal, Orissa and Andhra Pradesh, where the continental shelf is relatively wide, are the most productive. In Gujarat the major resources between 70-100 m were pomfrets, elasmobranchs, perches and cephalopods and between 100-200 m horse mackerel and threadfin breams are the major resources. In Maharashtra the ribbon fishes, pomfrets, and perches are the major groups in the 100-200 m zone. In Karnataka threadfin breams, bull's eye, drift fish and lizard fish are the important resources in the 70-200 m depth zone while on the continental slope (200-500m) black ruff and drift fishes are abundant. In Kerala cat fish and threadfin breams are the dominant resources in 70-100 m while the bull's eye becomes important in 100-200 m and green eye, black ruff and deep sea lobsters and prawns occur on the slope (200-500 m). The Wadge Bank is dominated by perches and balistids in the 70-100 m zone and threadfin breams and scads in the 100-200 m region, while deep sea sharks are found on the continental slope. In the Gulf of Mannar barracudas and crabs are abundant in 100-200 m while bull's eye, scads and threadfin breams are found on the slope (200-500 m). The Coromandal coast has cat fishes, scads and perches in 70-100 m, bull's eye, drift fish, scads and threadfin breams in 100-200 m and green eye, drift fish and cephalopods, on the slope region. Along the Andhra coast scads and cat fishes are dominant in 70-100 m, threadfin breams, bull's eye and scads in 100-200 m and black ruff in 200-500 m. A remarkable finding is that in the shelf region off the coasts of West Bengal and Orissa mackerel formed 22%-36% of the demersal catch from the 50-100 m zone and 8%-62% in 100-200 m; the slope region is dominated by bull's eye and cephalopods.

Concurrent with the above efforts of the FSI, the Indo-Norwegian Project (INP) which was established in 1952 at Neendakara and which was shifted to Cochin in 1963 started using small mechanised vessels (10.97 m) to explore the shrimp resources in the shallower regions of the continental shelf between Goa and

Mandapam Camp along the S. W. and S. E. coast and identified productive shrimp grounds off Karwar (9-33 m), Mangalore (16-29 m), Cannanore (9-25 m), Cochin (9-37 m) and between Alleppey and Quilon (9-37 m). The INP which was later taken over by the Govt. of India in 1972 and renamed as Integrated Fisheries Project also surveyed the deeper regions of the S. W. coast of India upto the continental slope with larger vessels. Apart from bottom trawling these vessels also experimented with pair trawling, single boat pelagic trawling, purse seining, hand lining and trapping and squid jigging. These operations in which the CMFRI also participated actively, revealed the existence of deep sea lobster resources between 180 and 270 m off Quilon and Mandapam, and deep sea prawn and fish resources on the Quilon Bank (300-450 m) (Tholasilingam *et al.*, 1964; Tholasilingam and Nair, 1968; Silas, 1969; Rao and George, 1973; Suseelan, 1974; Mohamed and Suseelan, 1973; Oomen, 1980, 1985; and Pillai and Sathiarajan, 1986). The existence of rocky grounds rich in rock-cods and other large perches between 8°N and 14°N latitudes on the west coast of India in 75-115 m depth was also brought to light (Silas, 1969).

The Pelagic Fisheries Project (PFP) at Cochin which was established with UNDP/FAO assistance in 1971 carried out extensive acoustic surveys with research vessels *Sardinella* and *Rastrelliger*, coupled with aerial surveys, for pelagic fish on the S. W. coast. During these surveys fishing with pelagic trawls was also done. Dense concentrations of white baits, horse mackerel, scads, ribbon fish and cat fishes were located along the S. W. coast and estimates made of their standing stocks (Menon and George, 1975; Rao *et al.*, 1977; Anon, 1976 a and b). The existence of mackerel and oil sardine shoals outside the presently fished inshore zone was also brought to light.

The tuna long-liner of the Central Institute of Fisheries Nautical and Engineering Training (CIFINET) has been conducting long-line fishing for tunas since 1981 in the Arabian Sea, Indian Ocean upto 6°S latitude, Bay of Bengal and the Andaman Seas. Very high hooking rates (upto 38.6%) for yellow fin tunas have been obtained off the the Karnataka-Konkan coast

between lat. 12°N and 15°N and long. 71°E to 73°E. These fishing grounds are hardly 120 nautical miles due west of Honavar (Swaminath *et al.*, 1987).

COMMERCIAL "DEEP SEA" FISHING VENTURES

There have been a few very successful commercial "deep sea" fishing ventures in the private sector. The New India Fisheries Company, Bombay had a very successful spell of bull-trawling during 1956-63 in the N. W. region between Bombay and Kutch. The two pairs of bull-trawlers (250 H. P. each) landed 26,304 metric tons of fish which was sold for 1.6 crores during this period. However the fishing operations were confined to less than 70 m depth (Rao, 1973).

The other success story was on the N. E. coast. The Union Carbide Company operated Mexican type outrigger trawlers with facilities for onboard freezing and packing. With Visakhapatnam as base these vessels were fishing along the Andhra, Orissa and West Bengal coasts mainly for shrimps. They started with 2 vessels in 1970 and because of their spectacular success introduced 2 more in 1975. However, their fortunes started declining in 1976 due to poor management and eventually collapsed in 1983. The catch details of these fishing operations of the Union Carbide vessels are not available but it is said that they got 7.2 tonnes of prawns per day (head-on weight) during the peak season and 1.7 tonnes per day during the lean season.

The early success of the Union Carbide vessels stimulated a number of private entrepreneurs and the State Fisheries Development Corporations to go in for large trawlers (23 m) mainly for shrimps. At present (1987) there are about 96 large trawlers (23 m and above) and 30 smaller trawlers (17 m) operating from Visakhapatnam fishing harbour. They are fishing between 15 and 100 m along the N. E. coast from Visakhapatnam to the Sandheads. These vessels discard most of the fish catch and bring back only the prawns in the headless condition. On an average each large trawler landed 43 tonnes of headless

prawns during 1983-84, 47 tonnes during 1984-85, 40 tonnes during 1985-86 and only 31 tonnes during 1986-87. The catches are clearly declining (Sudhakar Rao, MS). The value of the 3077 tonnes of headless prawns landed by the big trawlers at Visakhapatnam during 1986-87 is valued at Rs. 37.5 crores.

CHARTERING OF DEEP-SEA VESSELS AND JOINT VENTURES WITH FOREIGN COLLABORATION

The Government of India in a bid to stimulate interest in deep sea fishing introduced the charter and joint venture schemes in 1976. Under certain stipulated conditions companies could charter foreign vessels or enter joint ventures with foreign companies for deep sea fishing, boat building, processing and marketing of marine products. The purpose of these schemes was to import technical know-how in deep sea trawling, purse-seining, long-lining and squid jigging, modern fishing craft designs, boat building and to train Indian counterparts in all these activities. It was also felt that these operations would open up new fishing areas for deep sea fishing and lead to the building up of a sound indigenous deep sea fishing sector. However, these ventures did not work out very well due to various reasons. The chartered vessels have not given us any additional information on the resources. In fact the analysis of the catch of six confiscated poaching Taiwanese vessels (Joseph' 1981) has given us more information about the composition of the resources. At one time there were 108 chartered vessels fishing in our waters (Gokale, 1986). It was well known that they were fishing only between 30 and 40 fathoms. So when fishing of these vessels within the 40 fathom line was banned the chartered vessels quickly withdrew, obviously because it was not economical for them to fish beyond the 40 fathom line. However, the Govt. of India has again revived the charter and joint venture schemes in January 1987 after revising the terms and conditions.

MARINE FISHERIES RESEARCH

Marine fisheries research in India really started during the early part of this century with

James Hornell of the Fisheries Department of the Madras Province, who conducted a survey of the fishing methods of the Madras Presidency (Hornell, 1924, 1934) and initiated studies to understand the fluctuations in the oil sardine fishery on the west coast (Hornell, 1910; Hornell and Naidu, 1923) and the pearl fishery in the Gulf of Mannar (Hornell, 1905, 1916, 1922). He also tried to understand the factors responsible for the spawning of edible oysters (Hornell, 1910). However, after Hornell marine fisheries research languished and was revived again by Hora and his associates (Hora, 1934; Hora and Nair, 1940; Prashad *et al.*, 1940). The tradition has lingered in Madras (Devanesan, 1943.)

However it was only after the establishment of the Central Marine Fisheries Research Institute in 1947 that Marine Fisheries Research came into its own. The main objectives of the Institute are to estimate and monitor the catches of the various types of marine fishes landed by the different types of fishing gears all along the Indian coast throughout the year, to conduct research on marine fisheries resources in order to step up their production to the maximum sustainable level, to locate new fishing grounds, to conduct environmental studies in relation to fisheries and to develop indigenous technologies for culture of marine organisms with a view to generating additional resources for human consumption and to recommend measures for the rational exploitation of the various fishery resources.

The Institute has come a long way from its humble beginnings in 1947 and has become a premier centre for marine fisheries research in the S. E. Asian region. An update on the achievements of the Institute has been published recently (James, 1986) and the numerous publications of the Institute right from its inception have been listed in a bibliography published recently (CMFRI Special Publication No. 27).

The Central Institute of Fisheries Technology (CIFT) was set up in 1957 to undertake research on fishing craft and gear, post harvest handling, processing and packaging of fish, and quality control of fishery products. The

achievements of the Institute are highlighted in a recent publication by Nair (1986).

The National Institute of Oceanography (NIO) was set up in 1966 at Goa. The major objectives of the Institute are, advancement of knowledge about the Indian Ocean, development of mariculture technology, survey and exploitation of mineral resources, oil pipeline surveys, pollution monitoring and control, coastal development, development of marine instrumentation, establishment of an oceanographic data and information centre and participation in international oceanographic programmes and the Antarctic programme of the Govt. of India

Apart from these three national Institutes, the maritime Universities such as Andhra University, Madras University, Annamalai University, Kerala University, Cochin University Bombay University and the Fisheries Colleges attached to the Agricultural Universities of Tamil Nadu, Kerala, Karnataka and Maharashtra have made valuable contributions to the field of fishery science. The State Fisheries Departments of West Bengal, Tamil Nadu, Kerala, Maharashtra and Gujarat also have active research wings for tackling problems of local fishery importance.

The tremendous amount of research work done by the national Institutes and Universities during the 4-decades is commendable. These researches have brought to light the great scope for strengthening marine fisheries research in the following areas:

1. Monitoring and assessment of marine fishery resources and their response to fishing pressures.
2. The influence of environment parameters on the recruitment, availability and movement of fish stocks.
3. Estimating the population parameters of under-exploited fishery resources to assess their potential for further exploitation.
4. Further development of technologies for mariculture of marine organisms.
5. Improving the fuel efficiency of the fishing vessels and fishing efficiency of the gear.

DOMESTIC MARKET FOR MARINE PRODUCTS

Prior to 1947 the major part (51%) of the fish caught were sun-dried or salted and only 42.7% were consumed in the fresh condition. This was mainly because the landing places were not properly connected to the main roads for quick transportation of fish, nor were cold storage facilities available at most of the landing centres. Since 1966 however, the pattern of consumption of fish in the domestic market has

undergone a sea change. About 70% of the fish are marketed fresh. Cold storages, ice plants, processing facilities and transportation systems have been developed and fresh fish are transported to far off interior places to be sold in good condition. The rising standard of living of the people and the consequent change in their food habits have also resulted in the heavy demand for fresh fish. The changing pattern of fish utilization in the country can be seen from Table 2. For comparison the world figures for fish utilization are also given.

TABLE 2

Utilisation of fish in India and the world

	India				world
	1945	1961	1966	1979	1982
Marketed fresh	42.7%	47.9%	70.4%	65.1%	19.8%
Frozen	—	—	1.9%	5.6%	22.1%
Cured	41.0%	43.7%	21.9%	22.2%	14.4%
Canned	—	—	0.6%	0.2%	13.0%
Reduced	7.0%	8.4%	3.9%	5.4%	29.7%
Miscellaneous	—	—	1.3%	5.4%	1.0%

It is immediately apparent that the pattern of utilization of fish in India is entirely different from the average pattern observed in the other countries of the world, where only 20% is marketed fresh while the major part is processed into frozen, canned or reduced products.

In India fish which were once considered as "trash" have now become acceptable and have even become delicacies or costly exportable varieties. The domestic market for fish has been largely neglected since the export boom started in the early sixties. However the State Fisheries Departments have been trying their best to develop a good marketing system.

The IFP has done some pioneering work in this field by introducing diversified fishery products to promote domestic consumption of fish. The State Fisheries Marketing/Development Federations/Corporations in Tamil Nadu, Kerala and Maharashtra have also devoted much attention to promote the domestic consumption of fish through the fish stalls and

canteens which they have opened in the larger cities. It should also be remembered that there is still a great demand for dried and cured fish products in the interior places which should be properly exploited for the benefit of the fishermen and the consumers.

EXPORT OF MARINE PRODUCTS

Till early 1950s India was mainly exporting dried and cured fishery products to Hong Kong, Singapore, Burmah and Sri Lanka (Table 3).

TABLE 3

*Export pattern of fish products in 1945
(Average for 1941-45)*

Fish products	Quantity (tonnes)
Fish (including prawns) sun dried	12,512
Fish, dry salted	7,822
Fish, wet salted	1,743
Fish, maws & shark fins	225
Fish manure	4,038
	26,340

About 84.7% of the exports were dried or salted. Canned or frozen fish or prawns were unheard of.

But during the late fifties the demand for frozen prawns in the international market was increasing and some enterprising men in Kerala started freezing the prawns and exporting them mainly to the U. S. A. Because of the high unit price realised by frozen prawns in the international market it attained the number one position among the export marine products in the early sixties. Soon prawns were also canned and exported. Dried prawns continued to be exported but in declining quantities. The

trend in marine products export from 1965 to 1985 is given in Table 4. The canned prawns and dried prawns steadily decreased in importance as export items over the years (Table 4). There has been a gradual increase in the export of lobster tails. It is encouraging to note that the fresh/frozen fish export has picked up after 1975; the export of dried fish has been steadily declining but there are signs of it picking again in 1985 (Table 4). There has been a steady market for shark fins and fish maws from 1965 to 1985. Another encouraging trend is the steady increase in the export of frozen cuttle fish and squids from 1975 onwards.

TABLE 4.
*Pattern of marine products export from India (Q-quantity in tonnes;
V-value in thousands of Rs; figures in parenthesis are percentages)*

		1965	1970	1975	1980	1985
1. Frozen prawns	Q	7028(46.47)	22136(89.51)	46831(87.68)	47762(64.07)	49540(61.47)
	V	41422(69.83)	242515(88.21)	943386(89.93)	1833661(83.78)	3149837(93.89)
2. Canned prawns	Q	1148(7.43)	2578(6.93)	261(0.49)	365(0.49)	15(0.02)
	V	9606(13.73)	39541(11.13)	5999(0.57)	15794(0.72)	765(0.02)
3. Dried prawns	Q	1702(11.01)	1486(4.00)	99(0.18)	124(0.17)	117(0.15)
	V	5447(7.87)	8361(2.35)	1132(0.11)	1349(0.06)	1800(0.04)
4. Frozen lobster tail	Q	112(0.72)	382(1.03)	402(0.75)	501(0.67)	1465(1.82)
	V	1274(1.84)	6021(1.69)	15760(1.27)	27889(1.27)	120953(3.21)
6. Fresh and frozen fish	Q	8	6	134(0.25)	11195(15.02)	9557(11.86)
	V	30	42	1884(0.18)	111939(5.11)	162137(4.31)
6. Frozen cuttle fish & fillets	Q	nil	nil	1017(1.90)	1603(2.15)	4139(5.13)
	V			29071(2.77)	30326(1.39)	91657(2.44)
7. Frozen squid	Q	nil	nil	46(0.09)	2179(2.92)	3485(4.34)
	V			305(0.03)	25084(1.16)	43945(1.17)
8. Dried fish	Q	4431(28.67)	7269(19.55)	2295(4.30)	4340(5.82)	9022(11.20)
	V	6522(9.42)	18368(5.17)	9061(0.86)	20802(0.95)	79525(2.12)
9. Shark fins & fish maws	Q	244(1.58)	282(0.76)	307(0.57)	332(0.45)	242(0.30)
	V	2032(2.93)	5998(1.69)	9822(0.94)	32526(1.49)	31780(0.86)
10. Frozen frog legs	Q	443(2.87)	2545(6.85)	1317(2.47)	3095(4.15)	1785(2.21)
	V	2694(3.89)	32899(9.26)	27083(2.67)	73200(3.34)	63653(1.69)
11. Other items	Q	341(2.25)	480(1.34)	703(1.15)	3046(4.09)	1221(1.52)
	V	310(0.49)	1543(0.47)	6460(0.44)	16186(0.74)	10847(0.45)
Total	Q	15457	37175	53412	74542	80488
	V	69237	355359	1049063	2186756	3756699

Source: MPEDA Statistics of Marine Products Exports 1985.

The marine products exports from India have increased from 15,457 tonnes in 1965 to 80,588 tonnes in 1985, the value increasing from Rs. 6.92 crores to 375.67 crores in the same period. The quantity of frozen prawns rose from 2238 tonnes (19.3%) in 1962 to 49540 tonnes (61.47%) in 1985 and has become the mainstay of the marine products export industry, fetching a foreign exchange of Rs. 314.38 crores in 1985. This accounts for 83.7% of the total export earnings from all marine products. The major share (81.3%) of exported frozen prawns went to U. S. A. market in 1965, with Japan coming second (10%) and Australia third (7.8%). But over the years the trend as far as U. S. A. and Japan are concerned has been reversed, Japan absorbing 67.6% of the frozen prawns in 1985. The share of Australia has also gone down while the exports to U. K. have picked up slightly (8.5%) in 1985 (Table 5).

To look after the fast developing export trade in marine products the Marine Products Export Promotion Council was formed in 1961. This body was renamed Marine Products Export Development Authority (MPEDA) in 1972. The MPEDA's specific functions include registration of fishing vessels, processing plants and infrastructure facilities, laying down standards and specifications for marine products, improvement of marketing of marine products overseas by providing market intelligence, promotional activities, rendering financial and other assistance to exporters, regulation of export of marine products and arranging for training in different aspects connected with export. In recent years the MPEDA has gone in a big way to help promote brackishwater prawn culture

in the country. Apart from giving subsidies to prawn farmers and prawn seed banks, the MPEDA is also establishing large prawn hatcheries with foreign collaboration in various States.

DEVELOPMENT OF INFRASTRUCTURE FOR THE FISHING INDUSTRY

The major portion of the five year plan outlays have been spent on the development facilities for developing marine fishing industry. Fish are landed in 1414 landing centres along the long coastline of India and the fishermen who are bringing this catch live in 2408 fishing villages. If the fish landed at these sprawling centres are to be utilised efficiently by the country a vast amount of infrastructure facilities in the form of landing bases, connecting roads, transport vehicles, adequate water supply system, gear sheds, hard ground for drying of fish, ice plants, etc. have to be provided. Towards this end the centrally sponsored financial assistance schemes are operated by the State Fisheries Departments of all the maritime States to provide these basic amenities to as many fishermen villages as possible.

To accommodate the rapidly developing fleet of small mechanised boats the Government of India set up a Pre-investment Survey of Fishing Harbours project in 1968 with UNDP assistance. As a result of these surveys the Government have taken up the construction of 5 major fishing harbours and 83 minor fishing ports which are at various stages of completion. One more major fishing harbour

TABLE 5.

The share of major markets for frozen prawns in % (on the basis of quantity exported from India)

	1965	1970	1975	1980	1985
U. S. A.	81.27	63.18	29.07	13.85	18.59
Japan	10.40	29.93	64.54	76.28	67.62
Australia	7.82	3.25	2.60	0.87	0.37
U. K.	—	negligible	0.26	2.81	8.54
Others	0.51	3.64	3.53	6.24	4.88

and 15 minor ports are being provided in the Seventh Plan. It is expected that when these harbours are completed they will be able to accommodate about 16,000 small mechanised boats and 317 deep sea fishing vessels. This will still not be able to meet the requirements of the 31,000 small mechanised boats and 350 trawlers that are expected to be in operation by the end of the 7th Plan period.

On the processing and marketing side, apart from the lead given by the State Fisheries Departments in the construction of cold storages, ice plants, freezing plants, fish meal plants and canning plants, the private sector contributed a good deal in the construction of these infrastructure facilities. According to the survey conducted by the CMFRI in 1973-77 there are 264 freezing plants, 64 canning plants 131 ice making plants, 83 peeling sheds 31 fish meal plants and 319 cold storages in the country. The updated figures upto December 1980 are given in Table 6.

DEVELOPMENTAL ACTIVITIES OF THE STATE FISHERIES DEPARTMENTS

The State Fisheries Departments of all the maritime States have been actively engaged in various developmental activities to better the lot of the fishermen. They have played a key role in the mechanisation programmes by providing subsidies and arranging bank loans for the purchase of marine diesel engines, fishing nets and craft for fishermen through fishermen co-operative societies. Housing schemes for the fishermen are also managed by them. They have also formed co-operative marketing societies for marketing the catch of the fishermen in some places. They have established boat building yards for construction of mechanised fishing vessels, nylon net factories, and fishermen training centres for training them in operating the mechanised craft and gear and in maintaining the equipment etc. and have opened fishermen schools in many places. On the basis of Fish Farmers Development Agencies the Orissa State Department has formed

TABLE 6

Details of freezing plants, canning planning plants etc. upto 1st December 1980 (Capacity in tonnes/day)

State	Freezing		Canning		Ice making		Fish meal		Cold storage	
	Nos.	Capacity	Nos.	Capacity	Nos.	Capacity	Nos.	Capacity	Nos.	Capacity
Kerala	117	534	42	156.5	56	644	3	62.5	141	11548
Karnataka	29	113	9	38.0	15	212	5	150.0	31	2612
Tamil Nadu	46	180	3	4.5	36	335	6	62.0	60	5424
Andhra Pradesh	21	86	1	0.3	23	254	—	—	25	2096
Pondicherry	—	—	1	3.0	—	—	—	—	1	6
Lakshadweep	—	—	1	3.0	—	—	—	—	—	—
Maharashtra	41	288	3	5.5	5	218	6	95.0	46	7336
Gujarat	11	92	1	6.4	9	97	12	194.0	23	3283
Goa	12	45	7	33.5	2	19	1	12.0	9	560
Oriss	14	52	1	1.0	5	48	—	—	15	1150
West Bengal	31	96	—	—	5	90	1	14.0	27	1929
Total	322	1486	66	249.7	156	1917	34	589.5	379	35943

Source: Girija and Ravinath (1987)

Brackishwater Fish Farmers Development Agencies which have done a great deal to stimulate interest in prawn culture in the Chilka lake area. Other States are planning to start BFDAs on the Orissa model. The co-operative movement among fishermen was sponsored mainly by the State Fisheries Departments and it is estimated by CMFRI that there were 2759 Fishermen Co-operatives in the coastal regions of the country in 1973-77. Out of these only 748 were running successfully.

ANCILLARY INDUSTRIES

As a result of rapid mechanisation of the fishing industry a number of ancillary industries that supply the needs of the fishing community have sprung up in the private sector. The 1977 estimates are given here (Indian Fisheries, 1977).

Boat building yards: There were 69 registered wooden boat building yards for constructing mechanised boats, 16 shipyards for building trawlers and 3 yards for FRP boats. Recently a number ship building yards for building large trawlers utilizing the know-how from foreign boat building yards are functioning in the country. The country has adequate material, expertise and designs for construction of wooden and steel vessels upto 30m.

Marine diesel engines: There were 9 private firms manufacturing marine diesel engines in the country, the popular brands being "Kirlosker", "Meadows", "Leyland" and "Ruston".

Net factories: There were 4 net making plants in the public sector and 4 small ones in the private sector. 4 firms also produce nylon yarn for the fishing industry.

Others: Fishing floats, life saving equipment, trawl winches, reduction gear, stern gear, power take off clutches, auxillary engines, radio telephones, refrigeration equipment etc. are also manufactured in India.

MARINE FISHERIES EDUCATION AND TRAINING

In 1945 the Government of India sponsored the All India Fisheries Training Course at Madras

for training district level officers in marine fisheries. As part of the scheme for development of deep sea fishing in the country an *ad hoc* scheme for training of deck and engine side officers was initiated in 1948, under which the Deep Sea Fishing Station of the Government of India took apprentices on board their fishing vessels for providing training and sea time to persons who could subsequently appear for the MMD examinations for skippers and mates of fishing vessels. These marked the beginning of organised programmes for education and training in fisheries in India. With the introduction of mechanised fishing the need arose to train the fishermen in the operation of these boats. The fishermen Training Centre at Satpati established in 1954 with FAO assistance was the forerunner of similar centres which were soon established in all the maritime States.

It soon became clear that if the marine fisheries were to develop in India it is necessary to train four levels of personnel:

1. Operatives for small mechanised fisheries (Base level)
2. Personnel for manning ocean going vessels and shorebased personnel for handling, processing and marketing fish as well as for maintenance of vessel and fabrication of fishing gear (under graduate level):
3. Managerial personnel to plan and execute developmental programmes (graduate and post-graduate level).
4. Scientific and technical personnel for research in various areas of fisheries, exploration, development of new technologies etc. (post-graduate level).

1. **Base level training:** The Indo Norwegian Project established at Neendakara in 1952 as an area development project did pioneering work in this field. Subsequently the fishermen training centres on the Satpati pattern have been established in all maritime States by the State Fisheries Departments, for training the artisanal fishermen in the operation and maintenance of mechanised boats. The courses have teaching and practical components and extend over a period of 6 to 10 months. There were 31 such

training centres in the country in 1977 with a total intake capacity of 900 candidates. The requirements for this course is only basic education upto 5th standard and 5 years fishing experience. This course is meant for enterprising fishermen youth. The Krishi Vigyan Kendra of the CMFRI established in 1977 has been conducting short term training courses in prawn/fish culture in brackishwaters.

2. Under-graduate level training:

a. Personnel for manning of ocean going fishing vessels

All fishing vessels exceeding 25 tonnes gross tonnage should be commanded by duly certified deck officers and engineers as per the provisions of the Indian Merchant Shipping Act. Initially the programme for training these personnel through actual sea and engine room service was implemented by taking them as apprentices on board the vessels of the Deep-Sea fishing Organisation, IFP and West Bengal Government vessels. Regular institutional training was organised only after the establishment of the CIFNET at Cochin in 1963. A unit of CIFNET was started in Madras in 1968 and a third unit at Visakhapatnam recently. Candidates who wish to qualify as skippers (fishing vessels), Fishing Secondhands, Engineers (fishing vessels) and Engine Drivers, undergo institutional training for 15 months, followed by the requisite qualifying sea/workshop service before appearing for the Certificates of Competency examinations conducted by the Ministry of Transport and Shipping. The Institute also offers refresher courses for Fishing Secondhands and Engine Drivers appearing for higher Certificates of Competency. It also conducts refresher courses for Skippers in acoustic methods used in modern fishing, fishing fleet management and in diversified modern fishing methods. Matriculates are eligible for these courses. The syllabus for these courses is being revised according to the new Merchant Shipping Examination Rules, 1985.

With the introduction of more large trawlers for deep sea fishing the need for certificated hands is bound to increase and the required manpower needs will have to be assessed and provisions made for training them expeditiously.

Strategies have already been drawn up to meet these new demands (Swaminath, 1987).

b. Technicians for shore-based work:

The CIFNET offers courses for training (1) Boat Building Foreman (2) Shore Mechanics (3) Fishing Gear Technicians and (4) Fishing Vessel Electronic Technicians. The IFP conducts courses for refrigeration technicians, fish processing technicians, purse-seine operators, fishing boat designers and servicing of electronic equipment and engines.

The Central Food Technological Research Institute, Mysore offers a short term course in refrigeration techniques involved in food preservation, including fish and meat.

The College of Fisheries, Mangalore conducts a 3-month course for fish processing technicians already employed in processing establishments.

3. *Managerial level training:* The College of Fisheries, Mangalore attached to the University of Agricultural Sciences, Bangalore is the first professional fisheries college in the country, established in 1969, it has a regular 4 year degree course in Fishery Science leading to the B.F.Sc. degree. Subsequently four more Agricultural Universities have established Fisheries Colleges offering B.F.Sc. degrees in Fishery Science - Tamil Nadu in 1977, Kerala in 1979 and both Maharashtra and Orissa in 1981.

The Central Institute of Fisheries Education, Bombay, established in 1961 offers a 2 year post-graduate diploma course in Fishery Science mainly to district level officers deputed by the State Fisheries Departments. Private candidates are also admitted and the diploma is treated as equivalent to an M.Sc. degree for all practical purposes. From 1986 the Institute has started offering a Masters degree programme in Fisheries Management.

The Central Fisheries Extension Training Centre of the CIFE which has recently been shifted from Hyderabad to Kakinada conducts a 10 month course in extension techniques related to fish culture for in-service personnel.

The State Fisheries Staff Training centres in the maritime States conduct 1-12 months training for their in-service junior level personnel like Inspectors and Research Assistants.

The Trainers' Training Centre of the CMFRI has been conducting short term training courses in prawn farming, hatchery production of prawn seed, oyster culture, seaweed culture, SCUBA diving and assessment of marine fish stocks to officers of the State Fisheries Departments since 1985.

4. Training of scientific and technical personnel: The Fisheries College, Mangalore has M. F. Sc. programmes in Industrial Fishery Technology and in Fish Production and Management. It also offers Ph.D. programmes in Fishery Biology, Aquaculture, Fishery Oceanography, Aquatic Biology and Fish Processing Technology.

The CMFRI is conducting post-graduate and doctoral programmes in Mariculture for which the Cochin University of Science and Technology is awarding M.Sc. and Ph.D. degrees. This programme was started in 1979 with UNDP/FAO assistance as a Centre of Advanced Study in Mariculture at the CMFRI. After 1986 the project has become an integral part of the Institute as the Post-Graduate Programme in Mariculture.

The Fisheries College, Tuticorin has also started a M.F. Sc. course in Fisheries Science. The College of Fisheries, Panangad attached to the Kerala Agricultural University is also offering a M.F. Sc. course in Fisheries since 1986. The Cochin University of Science and Technology is offering M.Sc. degree course in Industrial Fisheries since 1976. The Kerala University offers a 2 year M.Sc. course in Aquatic Biology and Fisheries, while a two year M.Sc. course in Marine Biology is offered by Karnataka, Annamalai, Andhra and Cochin Universities.

SOCIO-ECONOMIC CONSEQUENCES OF PROGRESS ACHIEVED IN MARINE FISHERIES

The various developmental methods that have been adopted during the past 4 decades for developing the marine fisheries sector have no doubt improved the socio-economic status

of the marine fishermen. However, it is the segment of their population that has opted for mechanisation that has benefited much from these developments. The fishermen who have stuck to indigenous methods of fishing have also profited to some extent from the introduction of synthetic materials for net making, which has made their gears more efficient. But compared to the fishermen in the mechanised sector, the traditional fishermen are definitely poorer. Whether this is due to the adverse effect of mechanisation or due to the lesser efficiency of the traditional gear has to be looked into. The very fact that the mechanised sector (19,000 boats) has accounted for 61% of the total marine catch in India in 1981 clearly shows that the traditional sector (1,40,800 boats) which encompasses the majority of the fishermen is experiencing a set back

An analysis of the problem carried out by the CMFRI shows that there are three types of interaction between the mechanised and the traditional sector: (1) The mechanised sector competes with the traditional sector leading to clashes between them as in the case of the purse seiners and rampani operators in Karnataka. Jacob *et al.* (1979) have shown that the rampani operators were adversely affected by the introduction of purse seiners from the point of view of income and employment. The Karnataka Government took prompt action to encourage rampani operators to purchase purse-seiners by offering subsidies and loans and consequently the intensity of the problem is reduced. In other places where the small mechanised trawlers were fishing for prawns close to the shore where the traditional fishermen normally fish, clashes have been frequent. The State Fisheries Departments have intervened and demarcated the deeper areas for mechanised fishing and reserved the inshore areas for the traditional sector.

(2) The second type of interaction is complementary. Panikkar and Alagaraja (1981) and Sathiadas and Venkataraman (1981) who studied the socio-economic condition of fishermen in Puthiappa-Puthiangadi area and Sakthikulangara respectively found that mechanisation has benefited the entire fishermen population of the village. However the poorer section of the fishermen are left behind.

(3) Lastly the traditional fishermen themselves go in for motorisation of their indigenous craft. This has happened in Gujarat and Maharashtra on a large scale and is now catching up in Kerala also when they suddenly discovered that out-board motors could be easily fitted to their dug out canoes. This has increased their range of operation, reduced physical strain and increased the quality and quantity of their catches (Gopakumar et al., 1986).

Apart from these social problems, mechanisation can also affect the fish populations in some regions. The mass destruction of tonnes of cat fish carrying incubating eggs in the mouth by the purse-seiners on the Karnataka coast is a very dangerous practice indeed and could affect the recruitment of cat fish very adversely (Silas et al., 1980). It is also a well-known fact that wherever there is a dense concentration of mechanised boats all operating for prawns, the prawn catch rate has drastically come down. Although this is attributed to economic over-fishing it could easily lead to biological over-fishing unless the fishing pressure is reduced in time.

GENERAL REMARKS

It is evident from this review that India has made creditable progress in the marine fisheries sector in the past four decades. In spite of it the per capita availability of marine fish in the country is said to be only 4.57 kg (Silas et al., 1986). The gap between the supply of and demand for marine fish in the domestic market in 1985 was about 0.79 million tonnes (Silas et al., 1986).

The average growth rate of marine fish production has been about 3.5%. Unless the growth rate is increased considerably, the supply will continue to be far short of the demand. So there is an urgent need to accelerate the pace of fish production in the country. But this has to be done in a pragmatic manner.

A critical and calm appraisal of the marine fishery scenario outlined above brings to light some significant strengths and weaknesses in our approach to the problems.

There is no gainsaying the fact that the majority of our fishermen are still following

indigenous methods of fishing and by and large are still financially backward. This traditional fisheries sector cannot be neglected for two reasons, one is the social obligation to uplift the traditional fishermen. Secondly, in view of the rising cost of fuel we cannot afford to forget our traditional skills in fishing which depend more on muscle power and wind power. The efficiency of the traditional crafts and gear should be improved by directing research efforts in this direction also.

It is also fairly clear that the small mechanised boats should be made more fuel efficient by improving their design by scientific research and by introducing modern technological improvements like Kort nozzle for the propellers, etc. Since a good amount of power (40%) is consumed by the dragged gear like trawls, there is vast scope for improving the design of the otter boards and nets to reduce the drag and improve the efficiency. Bull trawling is also considered to be more fuel efficient as no energy is spent for keeping the trawl net open. All the trials conducted with bull trawlers of various sizes have invariably proved that the catch rate of a pair of bull trawlers is vastly greater than the combined catch rate of the two trawlers if they had operated along. This is also the lesson that the foreign poaching vessels (mainly Taiwanese) in our waters are trying to teach us. They are mostly bull trawlers.

Exploratory surveys conducted by the IFP along the south-west coast have brought to light the existence of rich "Kalava" grounds in 70-100m depth between 8°N and 13°N latitudes. These are rocky outcrops abounding in large sized (average 1.75 kg) perches which have a ready domestic market and which also do not spoil easily. Nature has provided us with natural FADs in these rocky outcrops within easy reach of our shores. It is upto us to exploit them.

As far as demersal fishery resources are concerned the exploratory survey vessels of the FSI and IFP, the foreign chartered trawlers and poaching vessels have clearly shown us that the commercially exploitable demersal resources of horse mackerel, perches, threadfin-brems, bull's eye, cephalopods, shrimps,

barracuda, lizard fish and ribbon fish are confined to the continental shelf region mainly upto a depth of 100 m. There are also some resources upto the 200m line but the distance between the 100 m line and the 200 m line is so narrow in most of the regions that the 100-200 m zone forms a very minor percentage of the area of our EEZ. For all practical purposes we should realize that our "deep sea" as far as the demersal resources are concerned is confined within the 100 m line and this is an area which is well within the range of operation and fishing capacity of the medium trawlers 17 m in OAL. The cost of these trawlers (Rs. 35 lakhs) is only 1/3 the cost of the 23 m trawlers (Rs. one crore) which are now proposed to be introduced on a large scale. The 17 m vessels can also be used to exploit the "Kala-va" grounds. With these vessels we can greatly and definitely improve the marine fish production. And they will be bringing in fish which are already familiar to our domestic consumers. However, since the operational range of these vessels is limited we may have to develop berthing and bunkering facilities for them in the minor fishing ports that are being constructed.

The so-called continental slope (200-500m) is a very steep and narrow zone where trawling is difficult and possible only in a few places like the "Quilon Bank" where the slope is less steep and more wide. The demersal fishes available on this slope are also small in size and may not be easy to market. For the present we need not devote much time and financial resources in catching these presently uneconomical fishery resources.

Regarding pelagic resources the surveys have clearly shown that vast under exploited resources of white baits are available even within the 50 m line on the south west and south east coasts. Between 50 and 200 m the existence of vast resources of horse mackerel, sards and ribbon fishes have been discovered. But these resources should be caught by pelagic/midwater trawl nets operated from paired vessels or single vessels and expertise in this field is still limited in our country. But these techniques have been used by the IFP, PFP and the FSI and it should not be difficult to popularise them. But more

research work is needed in this field to standardize the size and type of vessels and the gear.

The "Deep Sea" and the larger vessels become important only when we think of the oceanic tuna and squid resources for which there is a ready export market. The long-liners of the CIFNET and FSI have clearly proved the existence of very rich tuna grounds (probably the richest in the world) relatively close to the shore (100-150 nautical miles) between Mangalore and Goa. The existence of large oceanic squids in the deeper areas of the EEZ has been proved by these surveys. The tuna long-liners which are large vessels are needed to exploit these resources. The long-liners can also be equipped for squid jigging for catching the oceanic squids during night. This is the area in which we should really think of joint ventures with foreign countries. In this connection it is necessary to develop Goa and Mangalore into major fishing harbours which could handle these large vessels.

We should accept the fact that our chartering scheme has been a failure. It has not fulfilled the purposes for which it was started. It has not given us one bit more information about the location and magnitude of the fishery resources than what we already know about them through our own survey programmes. The confiscated poaching vessels have given us more information. This is because the chartered vessels have not provided correct information about the location and composition of the catch to the concerned authorities. Nor have they helped in training our men in modern fishing methods. The technology transfer through chartering is practically nil and it has not led to the establishment of Indian deep sea fishing ventures. If at all we have to go in for chartering the Government should charter the vessels and not the private companies. This has been the practice in other countries. The chartering of M.T. MURAENA by the Government of India has given a lot of reliable information on our fishery resources.

When we restrict Joint Ventures with foreign countries to the exploitation of oceanic tuna and squid resources, the much discussed problem of protecting our shrimp resources from the operations of these large foreign

vessels can also be solved. Regarding our prawn resources it is now abundantly clear that the inshore prawn resources upto the 50 m depth are being exploited at the maximum level and any further increase in catch is not possible even if the fishing effort is increased. It is also evident that the productive offshore prawn resources upto the 100 m line are restricted to the north east region and are at present being exploited by more than 100 large trawlers (23m).

Our studies clearly show that these resources also cannot withstand increased fishing pressure. So, for increasing prawn production in the country we have necessarily to resort to prawn culture in a big way. The efforts that are already afoot in this direction should be strengthened.

It is apparent that except for tapping the oceanic tunas and squids we may not need to go in for joint ventures. The other resources can be tapped by the 17 m vessels and the existing types of smaller vessels with suitable improvements and modifications and development of required infrastructure to facilitate the smooth functioning of these vessels.

We have been too much pre-occupied with the export market which consumes only about 10% of the marine fish production. The good work that has been done by the MPEDA and the EIC have brought our export earnings to Rs. 400 crores per year. It is planned to increase the earnings to Rs. 700 crores by the end of the seventh five year plan. We should realise the

limitations of the resource potential as far as the shrimps are concerned. There is an urgent need to diversify the export basket. There are already good signs of the exports of frozen fish, frozen cuttle fish and squids and dried fish picking up. These items are backed up by good resource potential and should be promoted.

But unless the domestic market for fish is stimulated the marine fishing industry cannot prosper. This is an area which needs immediate attention. Unless the fish caught are marketed efficiently the fishermen will not get proper returns on their catches and will not have the incentive to catch more fish. Facilities in the form of cold storages etc. to build up a buffer stock during glut periods will help stabilize the fish prices. Market surveys to assess the demand for the various types of fish products, development of diversified fish products packed in attractive consumer packs to suit the market demand, consumer education to popularise the new types of products, aggressive sales promotion drives, establishment of cold chains, provision of quick transport facilities and construction of hygienic fish markets should be undertaken urgently. The CIFT and IFP have already developed a number of diversified fishery products which should be taken up for marketing by the State Fish Marketing Federations/Corporations.

Lastly manpower planning and training of personnel for all the developmental activities should be given due importance to provide for the smooth functioning of the schemes envisaged to increase fish production in the country.

PLANNING FOR FISHERY DEVELOPMENT - SEARCH FOR APPROPRIATE POLICY INSTRUMENTS

A. G. Jhingran and S. Paul

Central Inland Capture Fisheries Research Institute, Barrackpore-743 101

ABSTRACT

The Indian fisheries economy for the last several years has been characterised by sluggish growth rates in production (3.5%), inadequate marketing infrastructure, demand and supply imbalances, inter-sectoral conflicts insignificant contribution of deepsea fishing (1%), Lack of diversification in export trade and apathetic entrepreneurship in offshore fishing. Further, gains from extension of Exclusive Economic Zone (EEZ) are likely to elude us for want of well-identified technological options along with production incentives for the exploitation of living resources of EEZ.

Unlike marine fisheries, inland fisheries have registered a higher growth rate of production. Despite imperfections of marketing system, land-based culture fisheries have been favourably placed, Fish Farmers Development Agencies (FFDA's) have brought 1,50,000 ha under scientific fish farming. Reservoirs (3 million ha) afford opportunities for enhancing inland fish production for augmentation of domestic availabilities.

The present paper purports to examine some of these areas so as to have a sound basis for the task of policy formulation for both marine and inland fisheries.

Of late, there has been a growing realisation that aquatic resources can contribute substantially to supplies of domestic food. Fish and fishery products being in the category of protective food, offer immense scope and potential for improving the nutritional status of mal-nourished millions who are, often afflicted with ailments due to protein and vitamin deficiencies. Lower per capita availability and high prices of fish do indicate demand and supply imbalances in the fishery economy. Without undermining the significance of research and development efforts during Plan periods, the Indian fishery scene has been marked by sluggish growth rate in production (3.5%), pronounced upsurge in fish prices, chronic shortages, distributional failures, lack of infrastructural facilities; predominance of traditional crafts, mainly due to higher capital requirements of mechanisation; and negligible contribution of deep sea fishing.

OVERVIEW OF INDIAN FISHERY ECONOMY

The Indian fisheries sector provides employment to 1.75 million skilled and unskilled persons in different activities. The total fish production as per available estimates is 2.8 million tonnes, of which one million tonne is

contributed by inland sector. The fisheries sector contributed about 2% to the Gross Domestic Product in 1982-83 and export earnings of marine products amounted to Rs. 461 crores in 1986-87.

The marine fisheries comprises three distinct subsectors: (i) traditional sector involving inshore water fishing with non-mechanised crafts and gears which operate upto 16km from the coast, (ii) modern sector consisting of small mechanised boats and (iii) ultramodern sector consisting of large vessels designed to operate in high sea, beyond the areas of the first two sub-sectors.

The traditional sector accounts for 67% of the current marine production of 1.8 million tonnes. The other two sectors contribute 32% and 1% respectively. This sectoral division is more academic than real. Often, there have been inter-sectoral conflicts, having Socio-economic ramifications. The emphasis in the recent past has been on the development possibilities of Exclusive Economic Zone (EEZ) but the primary producers of fish in traditional sector have not received adequate attention.

In inland fisheries, there exist vast opportunities for augmentation of domestic availability of fish. Fish production from inland waters is a significant activity as it is widely dispersed throughout the country. In the context of inland fisheries it was observed in the Sixth Plan that in spite of vast resources of culturable waters available in the form of ponds, lakes, jeels, swamps, estuaries and reservoirs, and availability of improved technology for intensive fish culture, levels of production and productivity had not been adequate. Therefore, the Plan laid emphasis on research efforts to maximise production and follow it up with promotional programmes in the field to reduce the gap between the potential and the actual yield. While the marine sector has largely sustained Indian export trade, the inland fisheries has contributed sizeably to domestic fish supply. The present annual production is about one million tonnes forming about 40% of the total fish production but accounts for 50% of the internal fish utilisation. Compared with the marine sector, the growth rate of inland fisheries has been more encouraging but still there exists a great scope for increasing inland fish production. Demand projections made by various expert bodies envisage that 50% of the demand of the total 12.5 million tonnes by 2000 A. D. is likely to be met by inland fish.

DATA BASE OF POLICY PLANNING

The planning has long been recognised as a potent instrument of socio-economic transformation in recent economic history of the world. A pre-requisite for sound planning is thorough survey of the existing resources and the extent of their exploitation so as to have a base for future projections. Unfortunately, the fishery sector in general and Inland fisheries in particular suffered largely due to almost non-existent data base for control and policy planning in respect of statistics pertaining to production, marketing intelligence and utilisation though foreign trade statistics have been in a better shape.

Data base for marine fisheries in general and of marketing and consumption segments in particular are very poor. There is a need for

developing sound data acquisition systems with cooperation from different sectors like small scale fisheries, mechanised sector and distant water fishing systems (IIM, 1983). Data base for inland fisheries suffers from the following limitations:

- i) Data on many aspects, particularly on marketing and economic aspects, are not collected in a systematised manner.
- ii) Data often reflect incomplete coverage.
- iii) Data are sometimes unusable because these are in aggregated form.
- iv) Market data on arrivals and prices are almost non-existent.

There is a need to strengthen, streamline and improve data base but our success in this direction is largely circumscribed owing to our ignorance as to how much resources in terms of finance and manpower we can commit to the task of data collection (Paul, 1987)

OVERVIEW OF FISHERY DEVELOPMENT

Despite massive development effort fishery economy had a sea-sawed journey during Plan periods. Though India's share in export trade increased progressively over the years, domestic fish markets continued to starve. Further, ever-firming fish prices resulted in reduced availability. Whereas exporters earned huge profits artisanal fishermen received unremunerative prices for their produce for the varieties that had no export market. According to findings of Indian Instt. of Management, Ahmedabad, the fisherman's share in consumer price was maximum (91.5%) in direct sales to the consumer and lowest (21.9%) in sales involving multi-distributional channels. Likewise, in inland capture fisheries the producer's price was only 35% of the consumer's price. However, the produce of pond-reared fish in eastern India was better placed (71-91%). Nursery rearing techniques along with a number of hatcheries were significant developments in the inland sector. Further, the role of F.F.D.A. as catalyst of technological transformation in culture fisheries was well recognised. In marine sector, the Government of India and research organisations

were fully seized of the problems relating to exploitation of living resources of the Indian Exclusive Economic Zone. Artisanal fishing is one of the high risk areas of economic activity and the entire traditional sector particularly engaged in inland capture fisheries, continues to be in a state of strife and turmoil. Research studies in Central Inland Fisheries Research Instt. as also in Indian Institute of Management, Ahmedabad, have revealed that vast majority of fishermen continued to be below the poverty line. There is a popularly held belief that capture fisheries in rivers, reservoirs, estuaries and oxbow lakes cannot contribute substantially to future increase in fish production thereby making a case for propagation of aquaculture. Natural fisheries, despite environmental degradation encountered in recent years, are still yielding 88% of the inland fish. Most of the thinking at policy and research level with regard to riverine and reservoir fisheries centered round the view that capture fisheries were beyond redemption. Diversification in export trade and research in end-uses of fish varieties having no domestic or overseas market rarely occupied the attention.

AREAS WARRANTING POLICY INTERVENTION

An attempt is made in the succeeding paras to identify certain areas deserving close attention in order to accelerate the pace of fishery development in India.

MARINE SECTOR

The major share of our fish production is contributed by a narrow belt along the coast, 35-40 fathoms deep. Diversification in this sector has shown marked improvement in quantity and quality of products.

With the declaration of 200 miles Exclusive Economic Zone, immense possibilities for exploitation of living resources do exist but our success will depend on rational utilization of resources along with appropriate techno-economic adjustments.

The labour-surplus countries like ours may improve employment prospects but capital intensive nature of investment besets the task with serious limitation. The absence of sizeable

and appropriate fishing fleet, adequate manpower and infrastructural facilities often reduce financial viability of operations. Research needs to be speeded up with regard to availability of commercially exploitable varieties and their end uses both in respect of domestic and overseas markets. For realistic investment appraisal, elaborate feasibility studies should be undertaken clearly outlining the technological inputs and post-harvest technology for the final disposal of the produce. Besides information inputs, financial assistance in the form of subsidies and soft loans is a condition precedent for giving initial *big push* to investment area unexplored so far. Research carried out so far reveals that potential yield beyond inshore water comprises low priced species like catfish, ribbon fish and 'dhoma'. The possibility of higher offtake in domestic market shall depend on income level, expenditure elasticities, consumer preferences and prices of close substitutes. In order to create favourable investment climate, existing policy relating to finance from S.F.D.C. and other regulations should be the subject matter of constant review. The investment in this sector may be largely induced by public sector allocations to infrastructure comprising landing and berthing and outfitting and repair facilities for handling, processing, storage and marketing network. (Jhingran & Paul 1987)

INLAND SECTOR

Riverine Fisheries

The various river systems in the country have an estimated linear length of 45,000 km comprising 113 rivers and their tributaries, 80% being contributed by 14 major rivers (Jhingran, 1986). The average catch ranged from 0.643 t to 1.605 t/km with an average of 1 ton/km (N.C.A. 1976). According to another study on the Ganga river, fisherman income is very low ranging from Rs. 1,000 (Hoshangabad, M. P.) to Rs. 5,316 in Mathura (U.P.). The riverine capture fisheries have been an area of low productivity and consequent low income due to seasonality of catch and unstable catch composition. The limited dent that research has made on the situation is not due to apathy or caprice of the scientist or policy makers but due to inherent limitations emerging out of

common property nature of riverine fisheries (Paul, 1983). Gulland (1971) has aptly remarked, "It is fallacy to think that scientists given time and perhaps money could produce complete answer to management problem e.g. specify the precise value of the maximum sustainable yield from a particular stock of fish and also the exact levels of fishing and population abundance required to produce it" Instead of delaying management decision for want of absolutely correct information it is better to take decision on the basis of sufficiently correct advice for the immediate purpose.

Financing of indian fisheries

Unlike marine sector, inland fisheries are labour intensive but still investment needs arise for purchase of boats and nets. However, capital requirements in case of intensive fish culture are higher. A sector's ability to attract loanable funds depends largely on evaluation of risk element by funding agency. Compared to culture fisheries which are site-specific, capture fishery operations have some ambulation about them. The migratory character of capture fisheries based on availability of stock and marketing consideration, does affect investment appraisal and assessment of credit needs (Paul, 1986). The vessel as a chattel mortgage is acceptable only if it is insured. The high degree of control puts aquaculturists on sound footing regarding anticipated output and repayment capacity as compared to capture fisheries. Capture fisheries are surrounded by innumerable and uncontrollable variables. This calls for innovative research in matter of efficient craft and gears along with insurance coverage. Further, traditional lending criteria need to be suitably modified keeping in view the level of assets of fishermen as a class.

Management strategy

Conventional prescriptions for regulations of fisheries comprises limited access, leasing and auctioning, closure of seasons and areas, licensing of gears, gear restrictions, aquacultural practices for enrichment of natural streams or rivers and security measures. The past experience shows that it is uncommon for Government to apply limited access concepts to communities utilizing riverine inland fisheries.

The main exceptions are leasing and auctioning of sections of rivers to local cooperatives as in South India. As a Government enforced mechanism, licensing of gear (especially boats and / or nets) has proved to be a reasonable mechanism only in inland fisheries which are relatively accessible (small lakes e.g. Lake Kyle in Zimbabwe; Anon, 1985). Their effectiveness can be increased further if loanable funds or subsidies can be restricted to licensees. If production and living standards of fishing communities are to rise without affecting adversely fish stock, management strategies should be well designed, implemented and periodically evaluated. Their effectiveness should be the subject matter of constant review by multi-disciplinary team of experts who should take cognizance of relevant data on commercial fishing, fluctuations in production, productivity, environmental and meteorological factors.

Fisheries cooperatives

The ills of cooperatives in fisheries are too well known to need elaborate mention. Cooperatives and state level corporations should enter into marketing of fish so that the influence of middleman is reduced to minimum if not eliminated altogether. The total membership of fishery cooperatives in the country is 7.77 lakh constituting about 1% of the fishermen population. Despite historicity of cooperative movement marketing continues to be the weakest link (Natarajan and Paul, 1981). The role of inland fishermen's cooperatives has been of less consequence when compared to marine fisheries. There is a need to create economically viable, technically sound and professionally managed fishery cooperative structure which should be able to lend stout support to fishermen. Creation of sound fishery cooperative network would open channels for financial assistance from National Cooperative Development Corporation and cooperative banking structure which should lead to creation of infrastructure assuring flow of effective services to the members. Once cooperatives and corporations attain commanding heights in fish marketing fishermen can certainly hope for a better tomorrow.

Fisheries legislation

The Indian Fishery Act, 1897 arms the states to frame rules for regulation of fisheries. By and large, this Act has been devoid of teeth at implementation level. It is too anachronistic to serve the objectives of present day fishery development. There is a need to have fresh thoughts with regard to its provisions. In riverine fisheries rules relating to mesh size and gear restrictions should be strictly implemented. Much of the damage to rivers, streams and reservoirs has been caused by discharge of untreated domestic sewage and industrial effluents. Therefore, there is a need for better coordination between fishery regulations and antipollution measures. The element of deterrence is sadly lacking in existing laws. Any conceivable piece of legislation should have twin objectives of conservation and development.

To sum up, the pace of fishery development can be accelerated by an ideal blend of regulatory measures and production incentives such as selective subsidies, soft loans for private sector, appropriate postharvest technology and remunerative returns to producers. Major thrust areas should include development of Exclusive Economic Zone, evolution of sound hatchery management practices in inland aquaculture and efficient marketing mechanism.

Any conceivable scheme of fishery development should have a strong bias in favour of small scale fishermen who have been denied the fair deal so far due to excessive reliance placed on the development of industrial fisheries in policy planning. Even, the current boom in export trade of marine products is sustained by the contribution of traditional sector. The possibilities of fishery development become bright only when we invest our present policies with much needed pragmatism.

REFERENCES

JHINGRAN, A. G. AND PAUL, S. 1987. Exploitation of living resources of Exclusive Economic Zone—problems and prospects. Souvenir published on the occasion

of Inauguration of Office cum Workshop Building of Visakhapatnam Zonal Base of Fishers Survey of India (19 July 1987).

JHINGRAN, A. G. 1986. Factors relevant to management and conservation of Ganga fishery resources. Presented at the Indo-US Workshop on Biomonitoring held at Jawaharlal Nehru University, New Delhi (10-14 Nov.)

SRIVASTAVA, U. K. AND DHARMA REDDY 1983. *Fishery development in India—certain issues in policy management concept*. Publishing House, New Delhi

PAUL, S. 1987. Inland Fisheries - A need for closer linkages between research and management. Paper presented at National Seminar on Current Status of Agro-based Technologies and Futuristic Approach to Rural Industrialisation held at NDUAT, Faizabad (7-9 February)

PAUL, S. 1983. Infrastructural base and support measures - A case study of West Bengal *Fishery Development in India—Certain Issues in Policy Management Concept*. Publishing House, New Delhi; 411-14.

PAUL, S. 1986. Financing inland aquaculture - Problem areas and policy options. *Published in—Fish Coops.*, NFFC, New Delhi (April-June).

NATARAJAN, A. V. AND PAUL, S. 1981. Post-Independence trends in fishery cooperatives and their relevance in marketing of Inland fish in India. *Published in Souvenir of All India Fishermen Cooperative Federation Limited, New Delhi*.

ANON. 1985, Management of Riverine Fisheries. *FAO Technical Report No. 263*.

GULLAND, J. A. 1971. Fishery management and the needs of developing countries: *World Fisheries Policy Multidisciplinary Views*. Edited by Briand J. Rothschild, University of Washington Press (Seattle and London) : 175-88.

MONITORING INDUSTRIAL EFFLUENTS DISCHARGE ALONG GUJARAT COAST BY BIO-ASSAY TEST AND PHYSICO CHEMICAL PARAMETERS

Y. B. Raval, V. R. Khadse, D. J. Vadher, M. Bhaskaran and N. D. Chhaya
Gujarat Fisheries Aquatic Sciences Research Institute, Okha,

ABSTRACT

GFASRI in consultation with Gujarat Pollution Control Board and on its own undertook studies on chemical parameters of effluents of a few factories in the Saurashtra region and their effects on fish through bio-assay tests.

In the case of M/s Tata Chemicals, LC-50 value ranges 0.4 to 5% conc vol; temperature 86.0 to 91.0°F; Ammonia 21.84 to 48.98 ppm and total solids from 184 to 234 g/litre.

In the case of M/s Saurashtra Chemicals, Porbandar, LC-50 value varied 2-100%. In the case of M/s Indian Rayon, Veraval, pH was between 2 to 10.5 and LC-50 value was from 20% to 100% conc/vol. For Billashwar Sugar Factory, Kodiner pH was between 4.0 - 5.5, BOD was 450 to 1600 ppm and LC-50 value was 0.5 to 7.

Results of investigations in general, factory-wise comments and impact of these studies in monitoring the effluents on the Gujarat coastline are discussed.

INTRODUCTION

Gujarat has five major rivers of 1,000 km stretch, 6,14,000 hectare area of ponds, lakes, reservoirs & swamps available for fish culture, and 1,92,000 sq. km area of continental shelf for marine fisheries resources.

With 472 fishing villages, 1,65,000 fishermen population, 6,000 non-mechanised boats, 5,000 mechanised boats, 3.3 lakhs tonnes annual fish production and export of fish/fish products worth Rs. 26 crores; the fisheries in Gujarat is not a small sector.

But Gujarat's major thrust has been on the industrial side, specially on chemical based industries. Increasing number of industries on coastal belt as well as on river banks has started creating problems of pollution in aquatic systems by releasing effluents. These have ultimate effects on fisheries resource too.

The Gujarat Pollution Control Board is concerned with protection of environment in the state. In consultation with them GFASRI initiated a small programme of studying effluents released by certain industries.

GFASRI has been registered in the INFOTERRA International Directory and has

been recognised as an environmental laboratory by the Department of Environment, Government of India. Thus the institute is privileged to take samples for analysis directly from factories on charge levied basis and it also examines sample from aquatic environment for study purposes and the obtained information are passed on to the concerned.

The present communication deals with the results of observations made on effluents from various factories in Saurashtra.

MATERIALS AND METHODS

Bio-assay tests and other parameters like pH, total solids, dissolved oxygen, suspended solids, carbon dioxide, chemical oxygen demand, dissolved solids, bio-chemical oxygen demand, ammonia, salinity, acidity, etc. were carried out as per methods recommended by pH standard methods for waste water examination as well as methods by Indian Standard Institute through different publications.

M/s TATA CHEMICALS, MITHAPUR

This factory releases two types of effluents at the mouth of Gulf of Kutch. Nature of the effluents are as in Table 1.

TABLE 1 Nature of effluents of Tata Chemicals

	A-Ammonia stell	B-Thermal power
Quantity	17740 M ³ /day	1360 M ³ /day
Temperature	86° C to 91° C	22° C to 39° C
pH.	10 to 11	8 to 9
Ammonia	21.84 to 48.98 ppm	0.64 to 43.6 ppm
L. C. 50. value	0.4 to 5% Conc/Volume	11 to 20% Conc/vol
Total solids	184 to 234 g/l	84 to 405 g/l
Dissolved Solids	171 to 210 g/l	46 to 122/l
Salinity	194 to 203 ppt	45 to 50 ppt
Suspended Solids	13.2 to 29.6 g/l	38 to 24.0 g/l

The above values are not in agreement with the ISI standards.

The factory excavated 9 ponds, each of 1 to 2 hectares. These ponds were used in series of three for settling suspended solids in the effluents. The ponds came into use from June-'85. Thereafter temperature of the effluents from Ammonia stell plant came down to 26° to 29°C, and Ammonia to NIL. The lethal-50 value improved at 5 to 17% Conc/Vol and there was some improvement in suspended and total solids too. However, there was no appreciable improvement in the effluent and as all the ponds got filled in within one year with solids this could not be a permanent solution. Thereafter in order to decide a safe dilution point at releasing end, experiments on bio-assay tests were conducted. Both effluents were allowed to run together for 100 m and then sample was collected. This sample was diluted to 20 to 25 and 30X and each dilution was studied separately to find out the lethal concentration value and the same is given below.

Dilution	LC-50 Value	
	Maximum	Minimum.
20 X	97	80
25 X	100	91.5
30 X	100	99

From the logarithmic plottings it was decided that 32X dilution was non toxic to fish and was safe for releasing to the Gulf of Kutch.

2. SAURASHTRA CHEMICALS : PORBANDAR

This factory produces soda ash, caustic soda and soda bicarbo. Raw materials used are salt,

lime stone, liquid ammonia, cock, coal, sulphur. It releases the sludge of Ca Co₃, Mg (OH)₂, NaCl, and Na₂ So₄ in liquid form at the rate of 8,400 kilo litres per day.

The temp. of the effluent ranged from 31°C to 40°C, PH 7.5 to 9.7, ammonia 6.44 to 6.77 ppm., total sulphate as (Na₂ SO₄) 20 ppm. total chloride as NaCl 90 ppm.

Lethal concentration on fish *Aphinus dispar* was below 20% Conc/Vol. Between April-'84 and June-'84. It showed appreciable improvement by remaining between 32% to 60% Conc/Vol. upto April-'85; thereafter there was further improvement and it ranged between 60 to 100% (non toxic) Physicochemical parameters were always in approximation to ISI stds. The monitoring was suspended from February '86. The improvement on the effluent was largely through additional dilution.

3. BILLESHWAR SUGAR FACTORY, KODINAR

This factory uses melasses, lime, sulphur and sugarcane as raw material and produces rectified spirit and crystal white sugar. The waste is being released to the sea at the rate of 850 KI/day near Mul-Dwarka fishing village.

The effluent had pH between 4 and 5.5, Dissolved Oxygen NIL total solids 13.6 to 44 g/l chemical oxygen demand 14,000 and 42,000 mg/l biochemical oxygen demand between 450 and 1,600 ppm activity 1,200 mg/l and LC-50 value ranged between 0.5 and 7. None of these parameters match with ISI standard.

There has been complaints from fishermen of Muldwarka for this effluent and further monitoring/improvement is necessary for this effluent.

4. INDIAN RAYON, VERAVAL

Using wood pulp, Caustic, Sulphuric Acid and Carbon disulphide this factory produces Rayon Fibre, zinc and vanadium pentoxide are used as catalysts. Factory releases effluent to the tune of 3,600 to 3,700 M³/day through open channel in Jaleshwar (Veraval) creek.

During 1980 the effluent was highly toxic and very few physico chemical parameters matched with ISI (Ruparellia et al. 1980).

The factory has installed lime addition, mixing plant as well Zinc settling/filtration plant and there was gradual improvement in the effluent quality. Temp was found between 25°C to 31°C pH from 2 to 10.5 BOD from 200 to 360 ppm and LC-50 value from 20% to 100% Conc/Vol (non toxic). But during surprise check, lime treatment plant was found unoperative, pH was found drastically low between 2 to 3 and LC-50 value was found very low between 20 to 26 Conc/Vol.

The effluent requires periodical monitoring.

6. M/S EXCEL INDUSTRIES, BHAVANAGAR

This factory produces yellow phosphorous, red phosphorous and sulfur and ammonium phosphides and use Rock phosphate, cock silica Urea, Wax, Ammonium carbonate, Thionyl chloride, Butene diet and Hexa chlore cyclo pentadiene.

The effluent quantity released is 2 to 3 lakhs litres/day the effluent has pH between 6 to 7, COD between 100 to 300 ppm and suspend solid between 5 to 200 ppm the LC-50 value was found 2% in 1984 it was 16.5% in February-'85.

The treatment to the effluent is given mainly through neutralization. The factory has installed activated carbon treatment plant, solar evaporation plant and filtration screens for solid wastes. However samples have not been tested thereafter.

The factory deals with highly toxic chemicals and hence periodical monitoring of effluent is necessary.

6. BHADAR RIVER (JETPUR NEAR RAJKOT)

There are around 1,500 printing industries

in Jetpur and Navagadh which are on the bank of river Bhadar and releases 8.26 million litre of effluent per day in the river the effluent is highly coloured (Red) with high COD, low BOD and high suspended and dissolved solids.

The L.C-50 value was found around 13% Conc/Vol.

IMPACTS OF THE WORK UNDERTAKEN BY GFASRI

1. GFASRI is getting recognition as an agency to shoulder responsibility to protect aquatic environment.
2. Earlier industrial units were either not aware of or never worried about that they were causing damages to near by flora, fauna and in all aquatic ecosystems by releasing their effluents and hence never bothered to treat their effluents. From the sequential experiences it can be informed that now an awareness is created among factory authorities about the damage caused to aquatic systems through release of untreated effluents. Many factories have installed treatment plants and have started putting efforts towards improvement of their effluents. Few factories have created special squads to look after their effluents.

REFERENCE

- BHASKARAN, M. AND CHAUHAN. H. D. 1975 "Pollution studies along the Saurashtra Coast." Symposium on "Multiuse of Coastal Zone" IFA, Bombay.
- CHAUHAN. H. D., and CHHAYA. N. D. 1977 "Preliminary Pollution Studies along Mithapur Coast". All India Seminar on Environmental Impact on Development Activity.
- CHAUHAN. H. D. AND CHHAYA. N. D. 1977 "Preliminary Pollution Studies along Porbandar Coast." Special issue of Jour. Inst. Pub. Health Eng., Indian Third National Convention on Environmental Engineering.
- PRASAD. K. N., NANDASANA D. V., TRIVEDI. C. R., BHASKARAN. M. AND CHHAYA. N. D. 1984 "Preliminary studies of

Sugar factory effluent Characteristics on Saurashtra Coast". (Unpublished) sent to NEERI., Nagpur for Ind. Jour. Environ. Health.

RUPARELIA. S. G , SHAH. N. C., PRASAD. K. N. AND BHASKARAN. M., 1981 "Studies on chemical characteristic of industrial effluents and recipient marine coastal

water with reference to ISI. International symposium on water resources conservation and pollution.

RAVAL. Y.B., NANDASANA. D.V., TRIVEDI. C.R. BHASKARAN, M., CHHAYA N.D. AND PRASAD. K. N., Studies on environmental disturbances by two soda ash factories on Saurashtra coast in Gujarat.

A BRIEF APPRAISAL OF MARINE FISHERIES IN INDIA

K. Alagaraja

Central Marine Fisheries Research Institute, Cochin

ABSTRACT

Using Relative Response Model and Maximum Contribution Approach, estimates on potential yield from the 0-50m depth area of Indian coastal waters are obtained as 2.20 and 2.00 million tonnes respectively. Basing on productivity estimates, potential yield from 50-200 m depth area is expected to be one million tonnes. It is suggested that no further increase in effort in 0-50 m depth is advisable. Instead, mechanisation of indigenous craft and/or replacement of existing small mechanised ones by medium sized vessels may improve the yield to 2.00 million tonnes. In the case of 50-200 m depth, introduction of 400 large vessels of length above 10 m is suggested.

INTRODUCTION

India with a vast coast line of more than 6500 km has rich marine fishery resources containing not less than 1000 species. Recent estimates indicate that there are resources accounting for about 4.5 million tonnes in the EEZ of this country for exploitation (George *et. al* 1977). These estimates are based on productivity studies and exploitation rates. At present the near shore areas stretching to not more than 50 m depth are intensively exploited by the small scale fishery sector comprising indigenous craft and small mechanised ones mainly operating trawls and drift/set gill nets. There are about 120 big trawlers in private sector, operating mostly in the east coast. Apart from them there are about 50 large vessels operated by the Government of India organisations for exploratory and research purposes. In fish production India ranks sixth in the world. In shrimp production and export it ranks second. From exports this

country earns about Rs. 390 crores annually. This paper presents the existing overall status of marine fisheries in terms of quantity exploited groupwise and the role of small scale and large scale fishery sectors. It also indicates the level of potential resources for exploitation using Relative response model and Maximum contribution approach. It also discusses the scope for intensifying fishing effort by way of introducing more gears and the scope for increasing yield from marine sector.

The Central Marine Fisheries Research Institute has been collecting data on the exploited marine fishery resources of this country for more than three decades for assessing their level of exploitation in terms of quantity caught and effort expended and biological and environmental aspects in order to find out the levels of effort suitable to harvest maximum sustainable yields. For this purpose, the Institute has developed a stratified multistage random sampling

design, the stratification being over space and time. This system of collection of data on marine fishery resources, vital for stock assessment studies is recommended by the FAO to other developed and developing countries. In the coverage of the CMFRI, data on exploitation of large vessels operated in the private sector are included as these are not made available to the National Marine Living Resources Data Centre of the CMFRI. The data base considered for this paper covers thus the small scale mechanised and non-mechanised fishery sectors only, the period of coverage being 1971-'81.

PRESENT STATUS OF EXPLOITED MARINE FISHERY RESOURCES

During 1971-'84 the total annual marine fish landings in India ranged from 9.8 to 16.3 lakh tonnes. This period witnessed the introduction of mechanised craft in the marine fishery sector and mechanisation of indigenous craft. The average during the first four years amounted to 11.45 lakh tonnes followed by 13.66 lakh tonnes during 1975-'79 and 14.46 lakh tonnes during 1980-'84 indicating the slow rate of increase during the period under consideration. This is an indicator to the fact that in the present area of exploitation substantial increase in the yield may not be expected from what is harvested at present. This period also witnessed intensive exploitation of demersal fishes particularly by smaller shrimp trawlers. The contribution from demersals was increasing from about 35% to almost 50% in the total landings, in this period. As expected the trend was similar in the case of mechanised sector but more impressive with about 20% initially and touching almost 70% in the end. (Anon, 1982; Anon, 1983 a; Anon, 1986 and Alagaraja *et. al*, 1982).

Clupeoids contributed about 27% of the total landings during this period out of which oil sardine accounted for 12%. The landings of oil sardine varied from 1.15 to 2.21 lakh tonnes. Prawns ranked second with 13% of which the share of penaeid prawns was 8%. The ranges of the landings of penaeid and non-penaeid prawns were 0.72-1.42 and 0.49-0.85 lakh tonnes respectively. The landings of Bombay duck varied from 0.52 to 1.38 lakh tonnes with an average contribution of 7% to

the total landings. Sciaenids landed in good quantities varying from 0.37 to 1.15 lakh tonnes accounting for 6% in the total landings. Heavy fluctuations were noticed in the landings of mackerel during 1971-'84, the range being 0.28-2.05 lakh tonnes, like of which no other group has experienced during the period under review. It accounted for 5% of the total landings. Cat fish, ribbon fish and silver bellies contributed 4% each to the total, followed by pomfrets, perches (3% each) and seer fish (2%).

PRESENT LEVEL OF FISHING

Though there was an increase in the total marine fish landings during 1971-'84, the trend was not uniformly increasing. There were fluctuations in the total as well as groupwise landings. In this context it is better to know the condition of the exploited marine fish stocks at the present level of fishing. Heavy fluctuations in the landings of some of the groups and later reaching a plateau raised doubts on overfishing. Overfishing can be considered under three categories. In economic overfishing, though the landings are not adversely affected, fishing activity becomes economically not viable. In such cases the effort pressure is automatically reduced so as to maintain the economic viability of fishing operations. Such a situation has arisen in some parts of the country leading to clashes between the indigenous fishermen and those operating mechanised boats. Clashes in Tamil Nadu, Kerala, Karnataka and Goa are indicators of this situation. These clashes are being averted by properly scheduling fishing operations (Jacob *et al*, 1979; Balakrishnan *et al* 1984 and Alagaraja *et. al*, 1982). The second type of over fishing is 'size overfishing'. Due to reduction in the mesh size it has been noticed that the size at first capture is very much reduced particularly that of prawns (Rao *et al*, 1980). In the initial stages the capture of larger fish and their reductions in the stock, leads to reduction in the average size of fish caught. This reduction gives chance to the younger fish to grow better in the absence of competition for food from the older ones. However, when the effort pressure is increased and mesh size reduced even the younger ones

are caught indiscriminately without allowing them to use their fast growing potential. This adversely affects the biological efficiency of the system. Hence such a tendency should not be encouraged. Finally comes the 'recruitment overfishing'. Since all living resources are renewable resources, their renewability could be maintained only when the recruitment is not affected. Capturing young fish in large quantities before they spawn may leave only a few fish to spawn and the resultant recruitment to the fishery may not be able to balance the loss due to natural and fishing mortalities. Hence once recruitment overfishing sets in, it adversely affects the stocks leading finally to their disappearance from the regions of fishing. Such a situation may happen purely by fishery dependent factors as in the case of cat fish in Karnataka (Silas et. al. 1980) or by the combination of fishery independent and dependent factors as in the case of Peruvian anchovies (Anon, 1983). All these three effects are felt though not in full extent in some region or the other in the Indian coastal waters demanding care and attention to the marine fishery in this country.

POTENTIAL YIELD IN 0-50 M DEPTH REGION

In the context of the above observations it is pertinent to know the level of potential yield. Estimates on potential yield or maximum sustainable yield could be obtained by using the well known macro and micro analytic models. Under micro analytic models the often used Beverton-Holt model is applicable for a fish stock and the non selective gear employed for its exploitation. As this model is gear and species specific its use is restricted to only those species for which information on growth and mortalities is available. To get an estimate on all India level, such a model has to be used for the most important groups of fishes and their MSY are to be added to get the total estimate. At present such studies have been made on a few groups namely prawns (Alagaraja et al, 1986), *Nemipterus* spp (Murthy, 1983) and cat fishes (Anon, 1987) to cite a few references. These studies have clearly indicated the necessity for mesh regulation in those regions where these stocks were exploited. However, an over all estimate on all India basis are not available even for these groups.

Under macro analytic models two models are used to find the level of potential yield and

to examine their comparability. As per the Relative response model (Alagaraja, 1984) for the period 1980-'84; the estimate of potential yield is 220 million tonnes as given in the Table 1.

TABLE 1.
Estimate of potential yield using relative response model

C_t	$C_t + 1$ ('000 t)	$C_t = C(1 - e^{-k}) + e^{-k} C_t$
1250	1379	$= 263.5 + 0.88 C_t$
1379	1421	$r = 0.94$
1421	1550	
1550	1630	$C = 2200$

Specieswise estimates of exploited marine fishery resources in India have not shown any interactive effect among them. In the absence of interaction among the exploited species 'Maximum Contribution Approach' (Alagaraja, 1986) could be used to obtain the potential yield. Under this approach during the period under review, the maximum landing of each group is taken. For this purpose the total landings are considered under 14 major groups. For example landings of penaeid prawns were the maximum in 1975 touching 1.42 lakh tonnes. Such maxima are obtained for all the 14 groups as indicated in Table 2.

TABLE 2.
Maximum contribution approach

Groups	Maximum landings ('000 t)	Percentage	Year
1. Oil sardine	221	11.2	1981
2. Other clupeoids	283	14.5	1984
3. Mackerel	205	10.4	1971
4. Bombay duck	138	7.0	1981
5. Penaeid prawns	142	7.2	1975
6. Non-penaeid prawns	85	4.3	1972
7. Sciaenids	115	5.8	1975
8. Catfish	76	3.9	1974
9. Perches	71	3.9	1974
10. Silver bellies	92	4.7	1983
11. Ribbon fish	78	4.0	1978
12. Pomfrets	54	2.7	1983
13. Seer fish	37	1.9	1984
14. Others	370	18.8	1984
Total	1967	100.0	

The grand total of these maxima is about 2.00 million tonnes which is the potential estimate under the Maximum Contribution Approach. This estimate is closer to the one obtained under Relative Response Model. Hence the exploitable potential yield may safely be taken as 2.00 million tonnes from the present heavily exploited area extending upto 50 m depth. It may be interesting to note that the estimate of 2.26 million tonnes obtained by George *et al.* (1977) for this region is very close to that obtained through Relative Response Model.

SCOPE FOR INTRODUCING ADDITIONAL CRAFT IN THE 50 M DEPTH REGION

From the foregoing it may be stated that the present yield of about 1.60 million tonnes could be raised to 2.00 million tonnes. For obtaining this additional yield of 4 lakh tonnes one would like to know whether the present level of effort, in terms of number of craft and gear, should be increased or not. As indicated earlier, clashes between small scale mechanised sector and the indigenous one have been reported in different parts of India particularly in the south west and south east regions. These clashes have affected the fishery very much. Hence introduction of additional small mechanised craft in these regions for exploiting the resources available in the 0-50 m depth area is not advisable. However motorisation of indigenous craft for operating gear and tackle such as drift/gill nets and hook and line may enhance the contribution from these units. Since the existing craft would be motorised under this scheme, clashes may not be expected and this approach may help the traditional fisherfolk to increase their revenue as the area of exploitation of each motorised indigenous craft would be extended, its mobility increased and hence such craft would be able to land fish in good and fresh condition fetching higher price. It is worthwhile, in this context to think in terms of replacing smaller crafts by medium sized ones so as to increase the fish hold capacity and the space for carrying ice.

POTENTIALITIES OF 50-200 M DEPTH REGION

At present exploitation of the resources in 51-200 m depth region is not as intensive as

in the area within 50 m depth. Hence a precise and reliable estimate on potential yield from this region on the lines indicated for the 0-50 m region, could not be made. This region is not supposed to be as biologically productive as the near shore areas. However, George *et al.* (1977) have indicated its potential yield equivalent to that of 0-50 m depth region. In other words according to them there exists another 2.0 million tonnes outside the present area of fishing ready to be exploited. From Jones and Banerjee (1973) primary production rate for 0-50 and 50-200 m on all India level are estimated at 1.21 and 0.28 $c_g/m^2/day$ respectively and the corresponding areas are 193 and 401 thousand sq km respectively. On the basis of these estimates, the potential yield of 50-200 m depth area may be equal to about half that of 0-50 m depth area. Regionwise break-up of potential yield is given in Table 3. The potential yield of the 0-50 m region is estimated at 2.00 million tonnes. Hence the estimate of the potential yield for the region 51-200 m is 1.00 million tonnes. This estimate appears to be a modest one.

TABLE 3.

Regionwise potential yield (lakh tonnes) and required no. of large vessels

Region	0-50 m	50-200 m	0-200 m	No of large vessels (above 17 m length) required in 50-200 m depth area.
North East (West Bengal and Orissa)	2.00	1.00	3.00	40
South East (Andhra Pradesh, Tamil Nadu and Pondicherry)	5.00	2.50	7.50	100
South West (Kerala and Karnataka)	6.00	3.00	9.00	120
North West (Goa, Maharashtra and Gujarat)	7.00	3.50	10.50	140
Total	20.00	10.00	30.00	400

To determine the level of effort required to exploit these resources information on types of vessels their holding capacity and break even point is needed so that their operations become economically viable. For instance for a larger vessel of about 23 m length, the fish holding capacity is 25 tonnes and it can stay out at sea for about 20 days. Out of this about 15 days are spent in fishing. On an average the vessel is expected to catch about 1.7 tonnes of fish per day. If this catch is made up of low quality fish, then the operation may not be economically viable. Hence to fix the No. of vessels required to exploit multispecies resources more information on the distribution of the resources over space and time and the economic viability of harvesting them by various types of gear-vessel combinations is needed. In the case of north east coast of India where large trawlers of length 23 m and above are operating mainly for shrimps required information is available. Hence it is possible to calculate the maximum yield of shrimps that this area can sustain and the optimum No. of vessels of length 23 m and above needed to judiciously exploit this resource. The MSY estimated for this region is 4800 t of shrimps and the optimum No. of trawlers is 104. Now there are about 120 trawlers operating in this region. Hence it is suggested to reduce the No. of trawlers from 120 to 100. Since such details are not available for the 50-200 m depth region, it is difficult to estimate the No. of vessels which should be deployed to optimally exploit the marine fishery resources of this zone.

Assuming, however, that large trawlers are expected to catch on an average 10 tonnes/day and taking 250 days in a year as the effective operation period for each vessel, total expected annual landings for each vessel may be put at 2500 tonnes. On this basis 400 such vessels are needed to catch 1.00 million tonnes.

From Table 3 it may be mentioned that large vessels numbering 40 may be introduced in the north east region, 100 in the south east region, 120 in the south west region and 140 in the north west region to fish beyond 50 m depth. At present there are about 120 large trawlers operating off the coasts of West Bengal, Orissa and Andhra Pradesh. These vessels are exploiting mainly prawns. As these

prawns are not deep sea prawns it appears that these large trawlers are operating in the relatively shallower regions. In the absence of the data on the exploited marine fishery resources by these vessels no conclusion could be drawn on the effect of operations of these vessels on the fish stocks exploited by them. However, it may be stated that large vessels may be directed to exploit deep water resources and the area with 0-50 m depth may be left to small vessels for exploitation.

Before the advent of mechanised craft, fishing gear in India was passive in the sense that gear was operated on the stocks approaching the fishing areas. After the introduction of mechanised craft, gear has become active and stocks are 'hunted' and fished as in trawling and purse-seining. While the gear is passive, exploited stocks are not adversely affected by the fishing effort. But when the gear is active and when the effort is intensive there are chances for recruit overfishing. Hence constant monitoring of the resources exploited by the active gears is required for their judicious management.

ACKNOWLEDGEMENT

The author is grateful to Dr. P. S. B. R. James, Director, Central Marine Fisheries Research Institute, Cochin for the encouragement during the preparation of this paper.

REFERENCES

- ANON. 1982. Trends in marine fish production in India - 1981, *Mar. Fish. Infor. Serv. T & E Ser.*, 41 : 1-33.
- ANON. 1983 a Trends in marine fish production in India - 1982 - 83. *Ibid.*, 52 : 1-21.
- ANON. 1983. Review of the state of world fishery resources - *FAO Fisheries Circular No. 710, Revision 3* : 1-41.
- ANON. 1985. Marine fish production in India- 1983-84 and 1984-85, *Mar. Fish. Infor. Serv. T & E Ser.*, 67 : 1-79.
- ALAGARAJA, K., K. NARAYANA KURUP., M. SRINATH AND G. BALAKRISHNAN 1982. Analysis of marine fish landings in India - A new approach. *CMFRI Spl. Publ. No.10* : 44 pp.

- ALAGARAJA, K. 1984. Simple methods for estimation of parameters for assessing exploited fish stocks. *Indian J. Fish.* 31 (2) : 177-208.
- ALAGARAJA, K. 1986. Maximum Contribution Approach for assessment of fish stocks (MSS).
- BALAKRISHNAN, G. AND K. ALAGARAJA 1984. Regulated mechanised and traditional fishing in Tamil Nadu. *Mar. Fish. Infor. Serv. T & E Ser.*, 58 : 10-13.
- GEORGE, P. C., K. C. GEORGE AND B. T. ANTONY RAJA 1977. Fishery resources of the Indian Economic Zone, *Souvenir. Silver Jubilee, IFP. Coch. India* : 79-116.
- JACOB, T., S. K. DHARMA RAJA AND K. K. P. PANIKER 1979. Socio-economic implications of purse-seine operations in Karnataka. *Mar. Fish. Infor. Serv. T & E Ser.*, 12 : 1-8.
- JONES, S. AND S. K. BANERJEE 1973. A review of the living resources of the Central Indian Ocean. *Proc. Symp. Living resources of the seas around India*. CMFRI. Spl. Publ. : 1-17.
- RAO, G. SUDHAKARA, C. SUSEELAN AND S. LALITHA DEVI 1980. Impact of mesh reduction of trawl nets on the prawns fishery of Kakinada in Andhra Pradesh. *Mar. Fish. Infor. Serv. T & E Ser.*, 21 : 1-6.
- SILAS, E. G., P. PARAMESWARAN PILLAI, M. H. DHULKHED, C. MUTHIAH AND G. SYDA RAO 1980. Purse-seine fishery - Imperative need for regulation, *Ibid.*, 24 : 1-9.
- SRIRAMACHANDRA MURTHY, V. 1983. Estimates of mortality, population size and yield per recruit of *Nemipterus japonicus* (Bloch) in the trawling grounds off Kakinada. *Indian. J. Fish.*, 30 (2) : 255-260.

RESEARCH IN MARINE CAPTURE FISHERIES

Paper 6

FISHERY AND BIOLOGY OF OIL SARDINE *SARDINELLA LONGICEPS* (VALENCIENNES) FROM COASTAL WATERS OF PARANGIPETTAI

K. Kumar and K. Balasubrahmanyam
Centre of Advanced Study in Marine Biology, Annamalai University
Parangipettai 608502

ABSTRACT

Although oil-sardine fishery is a major fishery on the west coast, it is a minor fishery in some places on the east coast. Information about *Sardinella longiceps* (valenciennes) on the east coast is scanty and the total catch landed at Parangipettai was about 79.95 tonnes from October 1985 to September 1986. Oil-sardine fishery was dominant in Parangipettai during July 1986 to September '86 amounting to about 70.5 tonnes. The length ranged from 102 to 103 mm in total length and nearly 60% of the catch comprised of fish above 150 mm in length. The size at first maturity was 156 mm for females and 158.5 mm for males and spawning was found to occur from July 1986 to September '86. A comprehensive study of the occurrence and biology of oil-sardine, *S. longiceps* on the east coast is needed to assess the resource potential.

INTRODUCTION

Marine fisheries play an important role in the national economy of our country. The annual catch for 1984-'85 consisted of 1,614,922 tonnes and the oil sardine, *Sardinella longiceps* (Valenciennes) is one of the major marine resources contributing to about 20% of the total marine catches. Oil sardine is a major fishery on the west coast restricted to Kerala and Karnataka states. Several studies have been made on the oil-sardine fisheries on the west coast. Only recently occurrence of oil-sardine in good numbers have been reported from the east coast (Gnanamuthu and Girijavallabhan, 1984; Ramasomayajulu and Dhana Raju, 1985; Srinivasarengan and Chidambaram, 1985). The present paper presents an account of the oil-sardine fishery in the coastal waters of Parangipettai during 1985-'86.

MATERIAL AND METHOD

Specimens of *Sardinella longiceps* (Val.) used in the present study were collected twice

in a week from the fish landing centre at Parangipettai for one year from October 1985 to September 1986. Total length of the fishes were recorded in mm from the tip of the snout to the longest ray of caudal fin. Sex, maturity stages and weight were also noted. The stomach contents were analysed by "points method" (Hynes, 1950) based on formalin preserved samples. For studying the maturation and spawning of *S. longiceps*, the size of the gonad in relation to body cavity, the general appearance, colouration, stage of maturity and weight were noted.

FISHERY

The total marine fish production during 1984-'85 was estimated at 1,614,922 tonnes of which the Indian oil sardine, *Sardinella longiceps* (Valenciennes) contribute about 1,65,000 tonnes. Srinivasarengan and Chidambaram (1985) reported an unusual landing of 57 tonnes at Pondicherry during October '83 to December '83. Oil-sardine is also caught in

TABLE 1.

Monthly landings of oil-sardine at parangipettai from October 1985 to September 1986.

Months	Landings in tonnes
October '85	1.25
November '85	0.80
December '85	0.50
January '86	0.30
February '86	0.30
March '86	0.40
April '86	0.50
May '86	0.90
June '86	4.50
July '86	19.50
August '86	30.00
September '86	21.00
	79.95

good quantities from Parangipettai and the total catch landed was about 79.95 tonnes from October 1985 to September 1986. (Table 1). Parangipettai fish landing Centre has 7 fishing villages namely Mudasodai, Annankoil, Parangipettai, Chinnoor South, Chinnoor North, Pudupettai and Puthukuppam and the craft engaged in oil sardine fishery was 'Catamarans', dug-out canoes and trawlers. Bottom-set gill nets (mesh size 2.5 to 4 cm) like "Kavala valai" and "Salangai Valai" are mainly employed for catching the oil sardine. Cast nets locally known as "Veechu valai" of varying mesh size are operated from dug-out canoe. The shoals of oil-sardine occurred at a depth of 10 meters in the inshore waters.

FOOD AND FEEDING

The food of *S. longiceps* consisted of 14 items. *Coscinodisus* sp. was always dominant and ranged from 17.26% to 44.82% in all size groups followed by *Plaurosigma* sp. and *Biddulphia* sp. in the order of abundance *Fragillaria oceanica* was less in the gut of fishes from parangipettai waters. Copepods, crustacean pieces, Tintinnids, bivalve larvae, *Lucifer*, *Evadne* sp. and zoea also occurred. Copepods formed the principal food of the

juveniles. In the 101-105 mm size groups, Copepods formed 28.66% but in 146-150 mm size group, the copepods contributed only 12.44% and less in higher groups.

LENGTH - WEIGHT RELATIONSHIP

Length-weight relationships in *S. longiceps* were studied by applying the formula $\log W = a + n \log L$ where,

W = weight, L = length

a = multiplying constant

n = exponent of length.

In the present study on 25 indeterminates, 150 males and 185 females, the relationship was found to be:

Indeterminates: $\log W = -0.8256 + 3.8056 \log L$.

Males: $\log W = -2.3645 + 3.1516 \log L$.

Females: $\log W = -3.0024 + 3.4436 \log L$.

The regression equation of males, females and indeterminates were subjected to analysis of covariance (F. test) to find the significance between the regression co-efficient. The data subjected for analysis of variance showed no variation between Male and Female, Female and Indeterminates, Male and Female & Indeterminates. Since there was no variation between male, female and indeterminates, the data have been pooled together and a common equation was derived.

$\log W = -3.2415 + 3.5505 \log L$.

SEX RATIO AND SPAWNING

648 specimens were examined and the ratio of males and females is 1.00 : 1.01. Sex ratio calculated for various months showed it has deviated slightly from the expected ratio 1 : 1.

Sex could be identified in specimens on attaining the length above 115 to 120 mm. Males were found to mature at 135-140 mm and females at 130-135 mm size. Maturity curve showed that 50% of females attained maturity at 156 mm and males at 158.5 mm.

PERIOD OF SPAWNING

The changes in gonado-somatic index were calculated for males and females and monthly average of gonado-somatic index (G. S. I.) is given in Fig. 1. High G. S. I. values of July-September indicate the spawning months of *S. longiceps*. The decrease in G. S. I. value in other months viz., from October to December may be due to spent condition in the fish during this period.

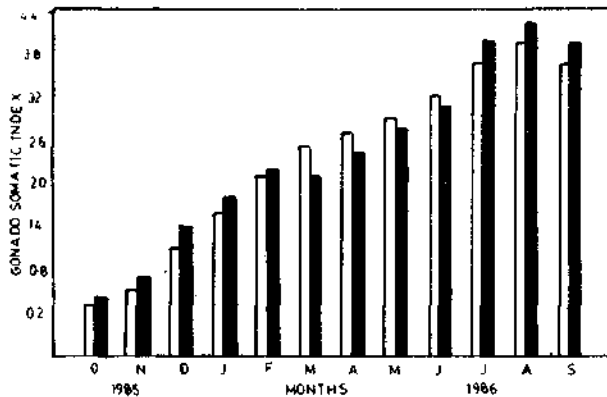

Fig. 1. Monthly average of gonado-somatic index of *Sardinella longiceps*.

DISCUSSION

The oil sardine, *Sardinella longiceps* forms a good fishery in west coast of India. Gnanamuthu and Girijavallabhan (1984), Ramasomayajulu and Dhana Raju (1985) and Srinivasarengan and Chidambaram (1985) reported about the occurrence of oil sardine from east coast also. Oil sardine regularly caught in Parangipettai and about 79.95 landed in 1985-'86.

In the present study, *Sardinella longiceps* showed preference of feeding exclusively on planktonic diatoms. This observation is similar to findings reported in Trivandrum (John and Menon, 1942), Calicut (Hornell and Nayudu, 1924; Nair, 1953; Venkataraman, 1961), Mangalore Dhulkhed, 1964) and Karwar (Noble, 1969). According to Nair (1953), Dhulkhed (1964) and Kagwade (1967), among the different diatoms found in the dietary of the oil sardine, *Fragillaria oceanica* Cleve formed the most important constituent and they found the existence of a significant correlation between the occurrence of this diatom and the

oil-sardine. However, in the present study *F. oceanica* was less in the gut contents of *S. longiceps* at Parangipettai waters. Bensam (1967) found that the juveniles of oil sardine feed mainly on zooplankton diet while the adults feed mostly on phytoplankton. In the present study also, the juveniles have fed more on zooplanktonic diet than on phytoplankton.

Hornell and Nayudu (1924) reported that oil sardine attained first maturity at the age of one year when they measured about 150 mm in length and this has been confirmed by other workers (Chidambaram and Venkataraman, 1946). Dhulkhed (1967) considered 160 mm as the minimum size at first maturity while Antony Raja (1967) reported it to be around 150-160 mm which is in agreement with the present study.

The spawning season of oil sardine has been variously recorded by several workers as May to August (Hornell and Nayudu, 1924), June to October (Antony Raja, 1967, '69), June to September (Nair, 1953; Dhulkhed, 1967) and June to December (Prabhu and Dhulkhed, 1967). Gnanamuthu and Girijavallabhan (1984) reported that the mature oil sardine occurred from January to March in Madras waters. In the present study, spawning season of *S. longiceps* in Parangipettai waters was from July to September.

REFERENCES

- ANTONY RAJA, B. T., 1967. Some aspects of spawning biology of Indian oil sardine, *Sardinella longiceps* (Val.) Indian J. Fish., (1964) 11A (1) : 45-120.
- ANTONY RAJA, B. T., 1969. The Indian Oil Sardine. Bull. Cent. Mar. Fish. Res. Inst., No. 16.
- BENSAM, P., 1967. Differences in the food and feeding adaptations between juveniles and adults of the Indian oil sardine *Sardinella longiceps* (Valenciennes.) Indian J. Fish., (1964), 11A (1) : 377-390.
- CHIDAMBARAM, K. and R. VENKATARAMAN, 1946. Tabular statements on the natural history of Certain Marine food fishes

- on the Madras presidency-West coast. Government Press, Madras, 1-26.
- DHULKHED, M. H., 1964. Observations on the food and feeding habits of the Indian Oil sardine *Sardinella longiceps* (Val.) Indian J. Fish., 9A (1) : 37-47.
- DHULKHED, M. H., 1967. Observation on the spawning behaviours of Indian oil sardine, *Sardinella longiceps* (Valenciennes) determined by Ova diameter studies. Indian J. Fish., (1964) 11A (1), 371-376.
- GNANAMUTHU, J. C. AND K.G. GIRIJAVALLA BHAN, 1984. A note on the occurrence of mature Oil sardine *Sardinella longiceps* (Val). Off Madras Coast. Indian J. Fish., 31 (3) : 378-379.
- HORNELL, J. AND M. R. NAYUDU, 1924. A contribution to the life history of the Indian Oil-sardine with notes on the plankton of the Malabar coast. Madras Fish Bull., 17 : 129-197.
- HYNES, H. B. N., 1950. The food of freshwater sticklebacks (*Gasterosteus aculeatus* and *Pygosteus pungitius*) with a review of methods used in studies of the food of fishes. J. Anim. Ecol., 19 : 36-58.
- JOHN, C. C. AND MENON, 1942. Food and Feeding habits of the oil sardine and mackerel Curr. Sci., 11 (6) : 243-244.
- KAGWADE, P. V., 1967. Food and Feeding habits of the Indian oil sardine *Sardinella longiceps* (Valenciennes) Indian J. Fish., (1964), 11A: 345-370
- NAIR, R. V., 1953. Studies on the revival of the Indian oil-sardine fishery. Proc. Indo-Pacific. Fish Coun., 1952 Sec. 2: 115-129.
- NOBLE, A., 1969. The food and feeding habits of the oil sardine *Sardinella longiceps* (Valenciennes) at Karwar. Indian J. Fish., 12A (1) (1965) : 77-87.
- PRABHU, M. S. AND M. H. DHULKHED, 1967. On the occurrence of small sized oil oil sardine, *Sardinella longiceps* (Val). Curr. Sci., 36 (15) : 410-411.
- RAMASOMAYAJULU, K AND K. DHANA RAJU, 1985. A confirmation of the occurrence of oil sardine *Sardinella longiceps* (Valenciennes) along the Orissa coast. Indian J. Fish., 32 (4) : 495-496.
- SRINIVASARENGAN, S. AND L. CHIDAMBARAM, 1985. An unusual occurrence of oil-sardine in Pondicherry on the east coast of India. Mar. Fish. Infor. Serv. T & E Ser., 61 : 16-17.
- VENKATARAMAN, G., 1961. Studies on the food and feeding relationships of the inshore fishes off Calicut on the Malabar coast. Indian J. Fish., 7 (2): 275-306.

ON THE FISHERY AND POPULATION DYNAMICS OF SEER FISH *SCOMBEROMORUS COMMERSON* (LACEPEDE) OFF TUTICORIN (GULF OF MANNAR)

H. Mohamad Kasim and K. M. S. Ameer Hamsa
Central Marine Fisheries Research Institute, Cochin - 682 031

ABSTRACT

On an average 34,476 t of seer fish were landed in India during 1982-1985. *Scomberomorus guttatus* constituted 50% of the total catch, *S. commerson* 49.1%, *S. lineolatus* 0.6% and *Acanthocybium solandri* 0.3%. In Gulf of Mannar, seer fish are exploited by drift gill nets of different mesh sizes, hooks and lines, trawl nets and to a limited extent by shore-seines. On an average 421.4 t of seer fish are being landed annually by all these gears along Tuticorin coast. The drift gill net, *paruvalai* landed on an average 156.7 t at the catch rate of 46.5 kg per unit. Hooks and lines landed annually 141.2 t at the catch rate of 14.6 kg per unit and trawl nets 113.4 t at the catch rate of 3.04 kg per unit. The smaller mesh sized drift gill net, *podivalai* landed on an average 10 t annually at the catch rate of 8.65 kg per unit.

The fishery of seer fish in Tuticorin is supported by *Scomberomorus commerson* (91%), *S. lineolatus* (6.9%) and *S. guttatus* (2.1%). The growth in length of *S. commerson*, estimated from length frequency studies, can be expressed by the von Bertalanffy growth formula (VBGF), $L_t = 1938 (1 - e^{-0.2008(t + 0.0835)})$. The growth in weight may be expressed as $W_t = 32002 (1 - e^{-0.2214(t + 0.1297)})^3$. The natural, total and fishing mortality rates have been estimated with respect to different gears. The yield per recruitment for different combinations of age at first capture and fishing mortality rates for the prevailing M/K ratio is estimated and given in the form of yield isopleth. The estimated optimum age of exploitation is 3.88 years and the potential yield per recruit is 1749 g.

The highly selective gears like the drift gill net, *paruvalai* and hooks and lines have been observed to exploit seer fish resource very effectively and more number of larger individuals have been caught. Therefore, exploitation by *paruvalai* with still larger mesh size and hooks and lines may be encouraged for enhancing the production of this resource.

INTRODUCTION

Seer fishes are commercially important scombroids caught all along the coastal waters of India. Though this resource forms a good fishery all along the Indian coast, the information available on the fishery and biology of the component species are limited. Hornell (1917) dealt the seer fish fishery of Tuticorin coast along with other important fishes. Subsequently Chacko *et. al.* (1962) have studied the scombroid fishery of Madras State. Silas (1962) has given an account on the fishery of seer fish while dealing in detail the fishery of tuna, sailfish and marlins along the Tinneveli coast. Biological aspects like food and feeding, growth and spawning of different species of seer fish have been studied by several workers (Vijayaraghavan, 1955; Krishnamoorthi, 1957; Nayar, 1958; Kaikini, 1960; Rao, K. Srinivasa, 1962; Kumaran, 1962). Devaraj (1977, 1982) has

worked in detail the growth and biology of seer fishes in Palk Bay. A detailed account is given on the fishery, extent of exploitation and population dynamics of the dominant species *Scomberomorus commerson* in this paper.

FISHERY

Fishing ground, season, craft and gear

This resource is being exploited all along the Indian coast by both mechanised and non-mechanised fishing units although the year by employing different types of gears like drift gill net, hooks and line, trawl net, shore-seine etc. Present exploitation is limited to the nearshore waters upto the depth of 50 m by trawlers and beyond 50 m by drift gill net and hooks and line units. Drift gill nets are of different types varying in mesh size from 25 mm to 205 mm with different vernacular names from region to

region. Smaller mesh sized gill nets are employed for exploiting smaller clupeids like sardines and anchovies and the bigger one for sharks and rays. Gill nets with larger mesh size from 120-170 mm have been observed very efficient in catching seer fish. Hooks of different sizes are used in hand line, long line and trolling. The gill nets and hooks and lines have been found to be highly selective and exploit this resource effectively whereas the trawl net and shore-seine are less selective and only smaller individuals of seer fish are caught more in these gears. Though this resource is exploited although the year, the peak period of fishing is during July to September off Tuticorin as in the west coast and November to January along the east coast.

Rate of exploitation

On an average 34,476 t of seer fish were landed in India in a year during 1982-83 to 1984-85 period (Table 1). The catch was constituted by the king seer, *Scomberomorus commerson* (49.1%), spotted seer, *S. guttatus* (50%), streaked seer, *S. lineolatus* (0.6%) and *Acanthocybium solandri* (0.3%). *S. commerson* constituted the major portion of the catch during 1982-83 and 1984-85. This species occurs predominantly along the southern coasts of India and *S. guttatus* occurs in good abundance on the northern coasts of India. *S. lineolatus* and *A. solandri* do not form a fishery anywhere and the occurrence of the latter is very sparse. This resource is exploited mostly

TABLE 1
Specieswise all India seer fish landing in tonnes from 1982-83 to 1984-85.*

Species	Year			Average	%
	1982 - 83	1983 - 84	1984 - 85		
<i>S. commerson</i>	19,799	13,433	17,548	16,926.7	49.1
<i>S. lineolatus</i>	176	286	186	216.0	0.6
<i>S. guttatus</i>	13,627	21,900	16,218	17,248.3	50.0
<i>A. solandri</i>	9	201	44	84.7	0.3
Total	33,611	35,820	33,996	34,475.7	

*Anon 1986

by drift gill nets and trawl nets along the northern coasts of India (Sudhakara Rao and Kasim, 1985; Kasim and Mohamad Zafar Khan, 1986). In southern coasts hooks and lines are also employed in addition to drift gill nets, trawl nets and shore-seines.

The fishery of seer fish in Gulf of Mannar is commercially very important as the fishermen migrate from northern coast of Tamil Nadu for exploiting this resource along with tuna during the peak fishing season from July to September every year. Among the different gears operated off Tuticorin, *Chalavalai* a type of drift gill net with mesh size 25-35 mm always landed only a very small size groups of seer fish during April-June and sometimes during September-November, whereas the *podivalai* another type

of gill net with mesh size 70-100 mm and trawl net land little bigger size groups. *Paruvalai*, a drift gill net with mesh size 120-170 mm and hooks and line always land bigger size groups and the larger individuals are dominant in the catches of these gears.

The observation on this fishery during 1980-85 along Tuticorin coast in Gulf of Mannar reveals that annually 421.4 t of seer fish were landed by *paruvalai*, *podivalai*, hooks and line and trawl net. Among the three species *S. commerson* constituted the major portion of the catch (91%) followed by *S. lineolatus* (6.9%) and *S. guttatus* (2.1%). The occurrence of *A. solandri* was very rare. *Paruvalai* landed on an average 156.7 t at the catch rate of 46.5kg per unit. There has been a decline in the catch

TABLE 2

Species composition, total catch, effort and catch per unit effort of seer fish landed by different gears operated off Tuticorin.

Gear	Year	<i>S. commerson</i> (kg)	<i>S. lineolata</i> (kg)	<i>S. guttatus</i> (kg)	Total (kg)	Effort (units)	CPUE (kg)
<i>Drift Gill net</i>	1980	197101	32194	2316	231611	3874	59.8
	1981	136508	35837	779	173124	3964	43.7
<i>Paruvalai</i>	1982	144175	12688	757	157620	4049	38.9
	1983	54810	8337	1335	64482	1584	40.7
Average		133148.6	22264	1296.8	156709.3	3367.8	46.5
<i>Podivalai</i>	1980	19159	2783	1094	23036	1791	12.9
	1981	3221	259	159	3639	531	6.9
	1982	3779	1065	420	5264	1119	4.7
	1983	7348	731	157	8236	1206	6.8
	Average		8376.8	1209.5	457.5	10043.8	1161.8
<i>Hooks & lines</i>	1980	185770	5995	365	192130	11723	16.4
	1981	96797	1166	—	97973	7462	13.1
	1982	152078	4756	645	157479	8979	17.5
	1983	111004	6037	188	117229	10476	11.2
Average		136412.3	4488.5	299.5	141202.8	9660	14.6
<i>Trawl net</i>	1984	62886	2066	3471	68423	29603	2.3
	1985	129276	1091	6845	137212	38177	3.9
	1986	124943	465	9290	134698	44228	3.04
Average		105701.7	1207.3	6535.5	113444.3	37336	3.04

rate from 1930 with marginal increase in 1983. *Podivalai* landed only 10 t in a year at the catch rate of 8.65 kg per unit. The trend in the catch rate was as observed in *paruvalai*. Hooks and line units have landed 141.2 t annually at the catch rate of 14.6 kg per unit and the catch rate was fluctuating. Trawlers landed on an average 113.4 t in a year during 1984-86 at the catch rate of 3.04 kg per unit (Table 2).

POPULATION DYNAMICS

The catch statistics of different gears reveal that the seer fish catch is constituted mostly by the king seer, *S. commerson*. It was felt essential that various population parameters such as the growth, mortality rates and yield per recruitment of this species have to be

studied for providing required information for better management of the fishery of this species. Forkal length in mm and wet weight in g of this species were collected at random from catches of different gears for length frequency and length-weight relationship of *S. commerson* can be expressed as $\text{Log } W = -1.9599 + 2.8479 \text{ Log } L$.

Growth

The gearwise primary data on the observed length frequency were initially raised to the day's catch and then to the month's catch to obtain the weighted length frequency at an interval of 25 mm. For the purpose of growth estimation the length frequency data from trawl and drift gill net were used as these gears are operated in the same fishing ground. A com-

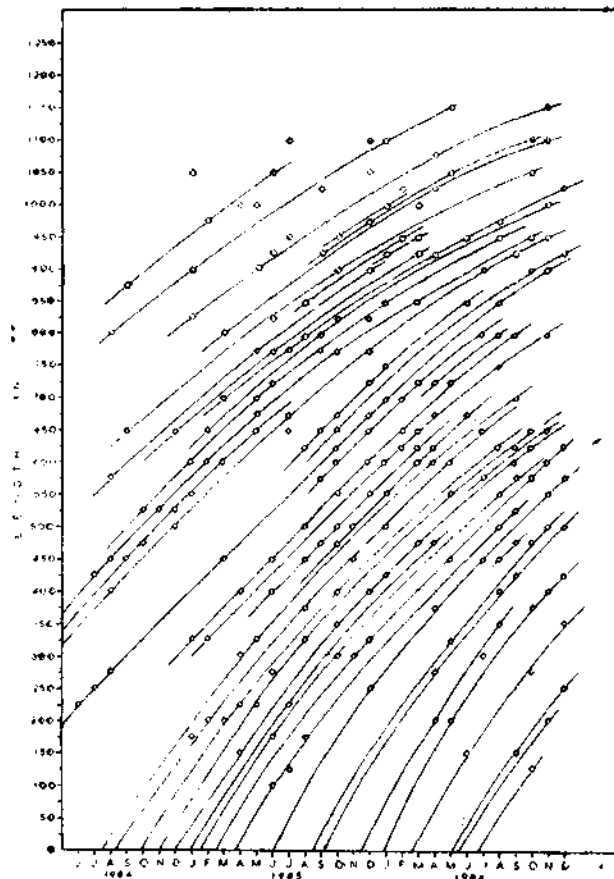

Fig. 1. Tracing of the progression of modes by scatter diagram of modal length-month for *Scomberomorus commerson* from Tuticorin

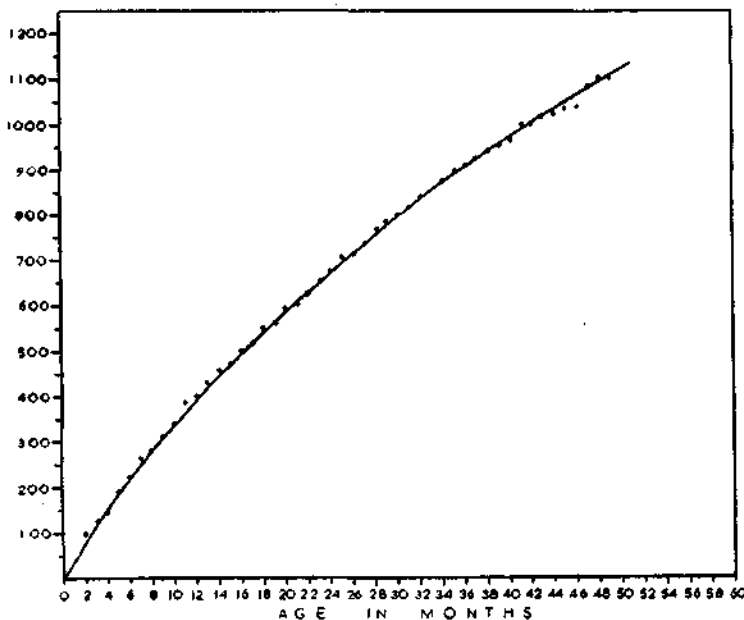

Fig. 2. Mean length at age in months based on the scatter diagram for *S. commerson* from Tuticorin.

bination of "Petersen method" and "Modal progression analysis" was used by plotting the modal lengths in the length frequency in the form of a scatter diagram. The progression of the modes is indicated by eye-fitted lines and these lines are extrapolated free hand so that they intersect the time axis indicating the time of brood origin as shown in Fig 1. The average sizes obtained from the modes traced in this way indicate roughly the length attained by the king seer in consecutive months. These values were plotted against respective months and the curve fitted through the plots represents the growth curve of this species (Fig 2). The half yearly growth of this species obtained from this analysis is 224 mm, 382 mm, 529 mm, 665 mm, 796 mm, 907 mm, 1015mm and 1088 mm in 0.5, 1.0, 1.5, 2.0, 2.5, 3.0, 3.5, and 4.0 years respectively. These data were further analysed as per the method of Bagenal (1955) by regressing L_{t+1} on L_t to obtain growth parameters like L_{∞} , K and t_0 . The growth in length of *S. commerson* may be expressed as per von Bertalanffy growth equation, $L_t = 1938 (1 - e^{-0.2008 (t + 0.0888)})$ and the growth in weight, $W_t = 32002 (1 - e^{-0.2214 (t + 0.1287)})^3$.

Mortality rates

The total mortality coefficient (Z) is estimated for *S. commerson* as per Beverton and Holt (1956) method from the relation $Z = \frac{K (L_{\infty} - \bar{L})}{\bar{L} - L_c}$ where L_{∞} and K are parameters of von Bertalanffy growth equation, \bar{L} is the mean length in the catch and L_c is the mean length at first capture. L_c is normally estimated from selection experiments, which, however, are rather time and resource consuming. The L_c of *S. commerson* for different gears have been estimated from the ascending limbs of the catch curves of the respective gear (Pauly, 1934; Devaraj, 1983) and it varied from gear to gear depending on its selectivity. The estimates of Z obtained by the above said method for different gears are given in Table 3.

The natural mortality coefficient (M) is estimated by regressing the annual effort on Z as per the relation $Z = M + qf$, where q is the catchability coefficient, which relates f and fishing mortality rates (F) through $F = q \times f$.

TABLE

Estimates of Z obtained from the average mean size at first capture (Lc) as per

Year	PARUVALAI (Lc 512.5mm)				HOOKS & LINES (Lc 575mm)			
	Effort (units)	L (mm)	Z	F	Effort (units)	L (mm)	Z	F
1980	3874	698.8	1.33	1.05	11723	815.7	0.94	0.56
1981	3964	681.3	1.49	1.07	7462	869.0	0.73	0.36
1982	4049	664.6	1.68	1.10	8979	848.3	0.80	0.43
1983	1584	778.9	0.87	0.43	10476	832.6	0.86	0.50
Average	3368	705.9	1.28	0.91	9660	841.4	0.83	0.47
Catchability coefficient 'q'	0.000271125				0.000048121			
M	0.43				0.37			
Average M	$1.28 - 0.91 = 0.37$				$0.83 - 0.47 = 0.36$			

Considerable difficulties are experienced in obtaining reliable estimates of M for tropical fishes by several workers (Pauly, 1980; Srinath and Alagarja, 1982; Yohannan, 1982; Devaraj, 1983). In the present study, M varied from 0.37 in hooks and line to 0.57 in trawl net. The independent estimate of M for *S. commerson* as per Pauly (1980) is 0.45. Devaraj (1983) has estimated the M to be 0.4 for this species in Palk Bay. The average value of M obtained from all the four gears is 0.48 (Table 3).

Yield per recruit

Yield per recruit estimated as functions of different fishing mortality rates and keeping the age at first capture constant for different M/K ratios are shown in Fig 3. The 'F max' which can produce the highest yield increases with the increase in M/K ratio. Yield per recruit estimated as functions of varying fishing mortality rates and different age at first capture for the prevailing M/K ratio 2.0 are given in the form of yield isopleth diagram in Fig 4, wherein the eumetric fishing curve (line A-A) and maximum sustainable yield curve (line B-B) are also given. The optimum age of exploitation is defined as the age when the brood attains its maximum weight (Beverton and Holt, 1957) and potential yield per recruit is the quantity corresponding to this weight as a function of infinite fishing intensity (Ricker, 1945; Holt, 1958). The estimated optimum age

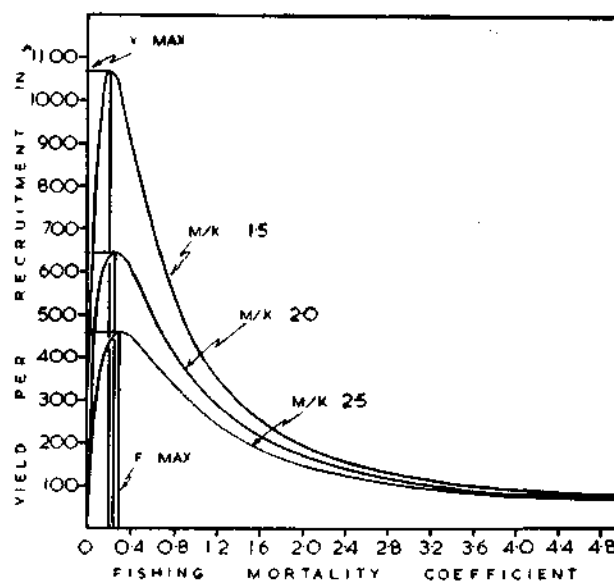

Fig. 3 Yield per recruitment of *S. commerson* at different M/K ratios and various fishing mortality coefficients. The corresponding yield max and F max are indicated for each curve.

of exploitation for *S. commerson* is 3.88 years and the potential yield per recruit estimated as per Krishnankutty and Qasim (1968) is 1749 g which is indicated in the yield isopleth diagram. The age at first capture pertaining to different gears presently employed in Tuticorin are indicated in the isopleth diagram with yield max and corresponding F which can produce the yield max.

3.

Beverton and Holt method (1956) and estimates F by regressing effort on Z .

Effort units)	PODIVALAI (Lc 325 mm)			Year	Effort (units)	TRAWL NET (Lc 212.5 mm)		
	L (mm)	Z	F			L (mm)	Z	F
1791	408.2	3.69	2.90	1984	29003	359.6	2.15	1.53
531	498.5	1.66	0.86	1985	38177	342.2	2.47	2.04
1119	466.2	2.90	1.81	1986	44228	321.3	2.98	2.34
1206	458.7	2.22	1.95					
1162	457.9	2.23	1.88		37136	341.0	2.49	1.97
	0.001609574				0.00005292			
	0.55				0.57			
	2.23-1.88 = 0.35				2.49 - 1.97 = 0.52			

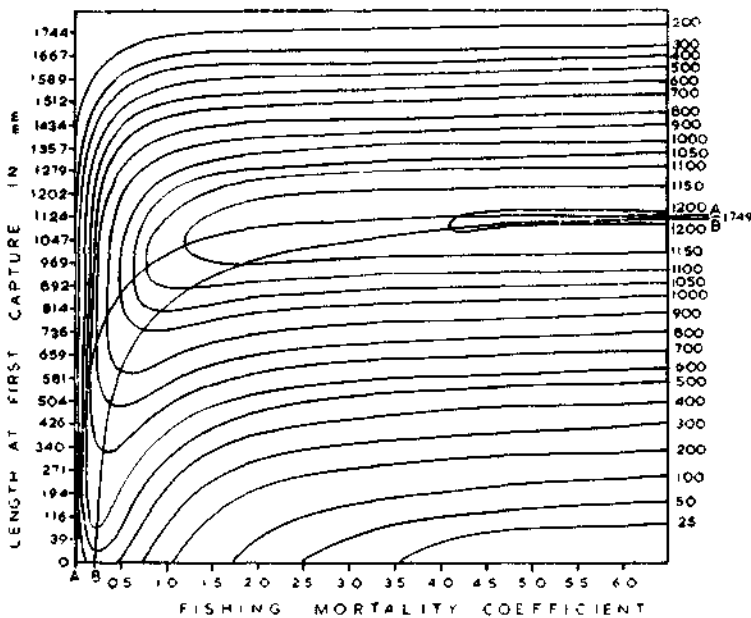

Fig. 4. Isopleth diagram for yield per recruit in grams of *S. commerson* population in Gulf of Manner. The line A-A indicates the eumetric fishing curve and the line B-B the maximum sustainable yield curve. The potential yield per recruit of 1749 g is also shown.

The yield per recruit for different age at first capture pertaining to different gears are shown in Fig 5. The F_{max} which can produce the yield max has not exceeded 0.5 for any of the gears; whereas the prevailing fishing mortality coefficient of these gears are well above 0.5 except the F for hooks and line (Table 3).

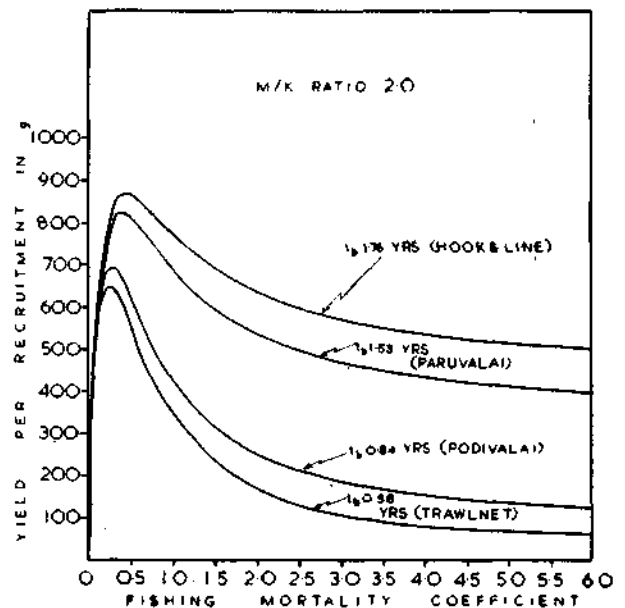

Fig. 5. Yield per recruitment of *S. commerson* at different fishing mortality rates and different age at first capture pertaining to different gear for the prevailing M/K ratio 2.0.

This indicates that the present effort input by by *paruvalai*, *pohivalai* and trawl net in Tuticorin is higher than the required levels and do not commensurate with the yield. The stock of *S. commerson* is under higher fishing pressure by these gears in Tuticorin waters. The increase in the overall production of seer fish by further increase in the effort of any of these gears without due consideration on the increase

in age at first capture, may not be appreciable as the yield per recruit tend to decline in higher fishing intensity for the prevailing age at first capture.

FISHERY MANAGEMENT

The fishery of seer fish in India is supported by the king and spotted seer whereas in Gulf of Mannar it is mostly by the king seer. The suggestions made here are valid only for Gulf of Mannar as the present study deals with the data collected at Tuticorin coast in detail. The fishing mortality coefficient, which varied from 0.47 for hooks and line to 1.97 in trawl net indicates that the present effort input by all the gears except hooks and line are higher than the required optimum effort and the yield is not commensurate with the effort expended. A moderate increase in age at first capture by these gears may improve the yield. Increase in mesh size. Increasing the mesh size of trawl net is not possible as the main aim of this gear is to exploit some other resource. Since as much as 113.4 t of seer fish of mostly smaller size groups are landed by trawl net, this gear may be considered as the most unfavourable for the exploitation of seer fish. *Podivalai* is mainly employed to exploit the resources like hilsa, chirocentrids, mackerel, belones etc. Though a very limited number of *podivalai* are in vogue, this gear is also not suitable for proper exploitation of seer fish. Therefore, *paruvilai* with increase in mesh size to 170-190 mm and hooks and line may be considered well suited for the exploitation of this resource and operation of these gears may be encouraged for easing the prevailing higher fishing pressure and to increase the seer fish production as well.

REFERENCES

- ANON. 1986. Marine fish production in India during 1983-84 and 1984-85. *Mar. Fish. Infor. Serv. T & E Ser.* 67 : 1-79.
- BAGENAL, T. B. 1955. The growth rate of the long rough dab *Hippoglossoides platessoides* (Fabr.). *J. Mar. Biol. Ass. U. K.*, 34 : 297-311.

- BEVERTON, R. J. H. AND S. J. HOLT. 1956. A review of the methods for estimating mortality ratio in exploited fish populations with special reference to source of bias in catch sampling. *Rapp. Cons. Explor. Mer.*, 140 (1) : 67-83.
- BEVERTON, R. J. H. AND S. J. HOLT. 1957. On the dynamics of exploited fish populations. *Fishery Investigations* (Ministry of Agriculture, Fisheries and Food, London), *Series 2*, 19 : 533 pp.
- CHACKO, P. I., S. D THOMAS AND C. MALU-PILLAI. 1962. Scombroid fisheries of Madras State, India. *Proc. Symp. Scombroid fishes*, MBAI, 3: 1006-1008.
- DEVARAJ, M. 1977. The biology and fishery for the seer fishes of India. Thesis submitted to the Madurai Kamaraj University for the award of Ph. D. degree, pp 337.
- DEVARAJ, M. 1983. M. 1983. Fish population dynamics-Course manual. *CIFE Bulletin*, 3 (10), pp. 98.
- HOLT, S. J. 1958. The evaluation of fisheries resources by the dynamic analysis of stocks, and notes on the time factor involved. *Pec. Publs. Int. Comm. NW, Atlant. Fish.*, 1 : 77-95.
- HORNELL, J. 1917. A statistical analysis of the fishing industry of Tuticorin (South India). *Madras Fish. Bull.*, 11 : 67-117.
- KAIKINI, A. S. 1960. The fishes of Malwan. *Indian J. Fish.*, 7 : 348-368.
- KRISHNAMOORTHY, B. 1957. Fishery resources of the Rameswaram Island. *Indian J. Fish.*, 4 (2) : 229-253.
- KRISHNAN KUTTY, M AND S. Z. QASIM. 1968. The estimation of optimum age of exploitation and potential yield in fish populations. *J. Cons. perm. int. Explor. Mer.*, 32 (2) : 249-255.

- KUMARAN, M. 1962. Observations on the food of juveniles of *Scomberomorus commerson* (Lacepede) and *S. guttatus* (Bloch and Schneider) from Vizhinjam, West coast of India. *Proc. Symp. Scombroid Fishes*, MBAI, 2 : 586-590.
- KASIM, H. M. AND MOHAMMAD ZAFAR KHAN, 1986. A preliminary account on the gill net fishery off Veraval during 1979-82. *Indian J. Fish.*, 33 (2) : 155-162.
- NAYAR, S. G. 1958. A preliminary account of the fisheries of Vizhinjam *Indian J. Fish.*, 5 : 32-55.
- PAULY, D. 1980. A selection of simple methods for the assessment of tropical fish stocks. *FAO Fisheries Circular 729*, FIRM/129, pp. 54.
- PAULY, D. 1984. Length converted catch curves: A powerful tool for fisheries Research in the tropics (part II)^a. *Fishbyte*, 2 (1) : 17-19.
- RAO, G. SUDHAKARA AND H. MOHAMAD KASIM. 1985. On the commercial trawl fishery off Veraval during 1979-82. *Indian J. Fish.*, 32 (3) : 296-308.
- RAO, K. SRINIVASA. 1962. Observation on the food and feeding habits of *Scomberomorus guttatus* (Bloch & Schneider) and juveniles of *S. lineolatus* (Cuvier & Valenciennes) and *S. commerson* (Lacepede) from the Waltair coast. *Proc. Symp. Scombroid Fishes*, MBAI, 2 : 591-598.
- RICKER, W. E. 1945. A method of estimating minimum size limits for obtaining maximum yield. *Copeia*, No. 2 : 84-94.
- SILAS, E. G. 1962. Tuna fishery of the Tinneveli coast, Gulf of Mannar. *Proc. Symp. Scombroid Fishes*, MBAI, 3 : 1083-1118.
- SRINATH, M. AND K. ALAGARAJA. 1962. A method of estimation of mortality rates from length samples. *Indian J. Fish.*, Vol 29 (1 & 2) : 183-188.
- VIJAYARAGHAVAN, P. 1955. Life history and feeding habits of the spotted seer *Scomberomorus guttatus* (Bloch & Schneider). *Indian J. Fish.*, 2 : 360-372.
- YOHANNAN, T. M. 1982. Population dynamics of Indian mackerel based on data from Mangalore during 1967-75. *Indian J. Fish.*, 29 (1 & 2) : 50-62.

THE PRESENT STATUS OF POLYNEMID FISHERY IN INDIA

P. V. Kagwade

Bombay Research Centre of C. M. F. R. Institute, Bombay-400001.

ABSTRACT

The polynemid fishery which is not of a big magnitude has shown rise and fall in the catches during the last 30 years from 1956 to 1985. The fishery whenever dropped in the north west coast showed improvement along the east coast. Though represented by 9 species most of which have fisheries of very small magnitude, the overall fishery is supported mainly by *Polydactylus indicus* ('Dara') and to a lesser extent by *Eleutheronema tetradactylum* ('Rawas') both growing to over a meter in length and weighing more than 18kg. Because of the dominance of *P. indicus*, fluctuations in its catches are reflected on the fluctuations in the total polynemid catches. The decline in the catches in sixties is attributed to the heavy landings of 'Chelna' which are nothing but juveniles of 'Dara' in the fifties and sixties by the commercial trawlers. Added to this are certain biological facts 'Dara' matures in the IVth year and is a gonochoristic hermaphrodite in which the ovarian part of ovotestis becomes active alternatively with the testicular part and in this process the period for an individual to reproduce the progeny is reduced to half. Hermaphrodites are also encountered in other polynemid species.

Cessation of trawling in the nursery grounds of 'Dara' due to the concentration of fishing for prawns in other areas in late sixties and seventies has helped the fishery to revive in seventies and eighties and conserved the species at the present level. The traditional fishermen use a highly selective gear namely 'Waghra Jal', a bottom drift gill net for 3-4 months in a year during the spawning migration of this species towards the Gulf. This by itself is a good management policy to conserve such an important fishery, in spite of its moderate magnitude.

INTRODUCTION

Polynemids, though belong to a resource of a moderate magnitude, have attained a unique place among the quality fishes. They still command the age old popularity as highly esteemed table fish. They move in small schools and contribute to the coastal fisheries of this country. When trawling started in fifties on commercial scale, *Polydactylus indicus*, one of the polynemid species growing to over a meter in size and called as 'Dara' along the north west coast, gave an impressive sight of its abundance by its huge landings, not known earlier. The catches dwindled in sixties and gradually this species has become very rare these days in the trawlers landings. Similarly *Polynemus heptadactylus*, another species growing to less than about 1/3 of a meter which occurred in trawler landings in substantial quantity in the early years, has declined drastically these days. A critical study and analysis of such an important fishery of polynemids by virtue of its being a highly favoured one, is all the more important

at present, no matter what its magnitude is. Data available for the past 30 years from 1956-1985 with the Central Marine Fisheries Research Institute should hold the key to exploit, conserve and manage this fishery.

CATCH

Polynemids during the 10 year period 1956-65 were reported to form annually 0.80% of the total landings (Kagwade, 1968 a). Trend of the fishery (Fig 1) for this group of fishes for the past 30 years from 1956 to 1985 indicated that during the later half of fifties, the annual average catch of polynemids was 1.16% in the total fish landings. The catch declined in sixties and gave an annual average of 0.46%. The trend in the early part of seventies till 1976 was towards improvement, recording an annual average catch of 0.84% of the total landings. The catch declined again from 1977 onwards and fluctuated between 0.31% and 0.59% giving an annual average of 0.42% in the total landings till 1985.

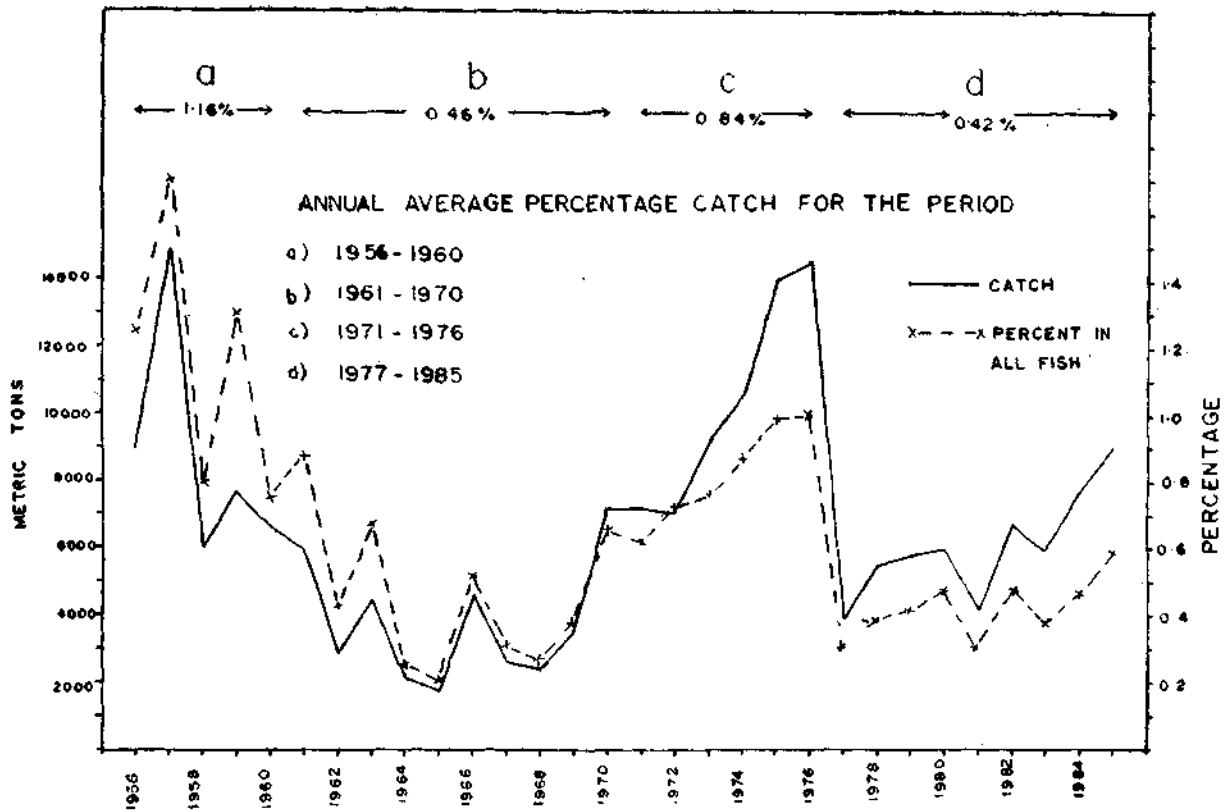

Fig. 1. Annual catch and percentage catch of polynemids in India for the period 1956-1985.

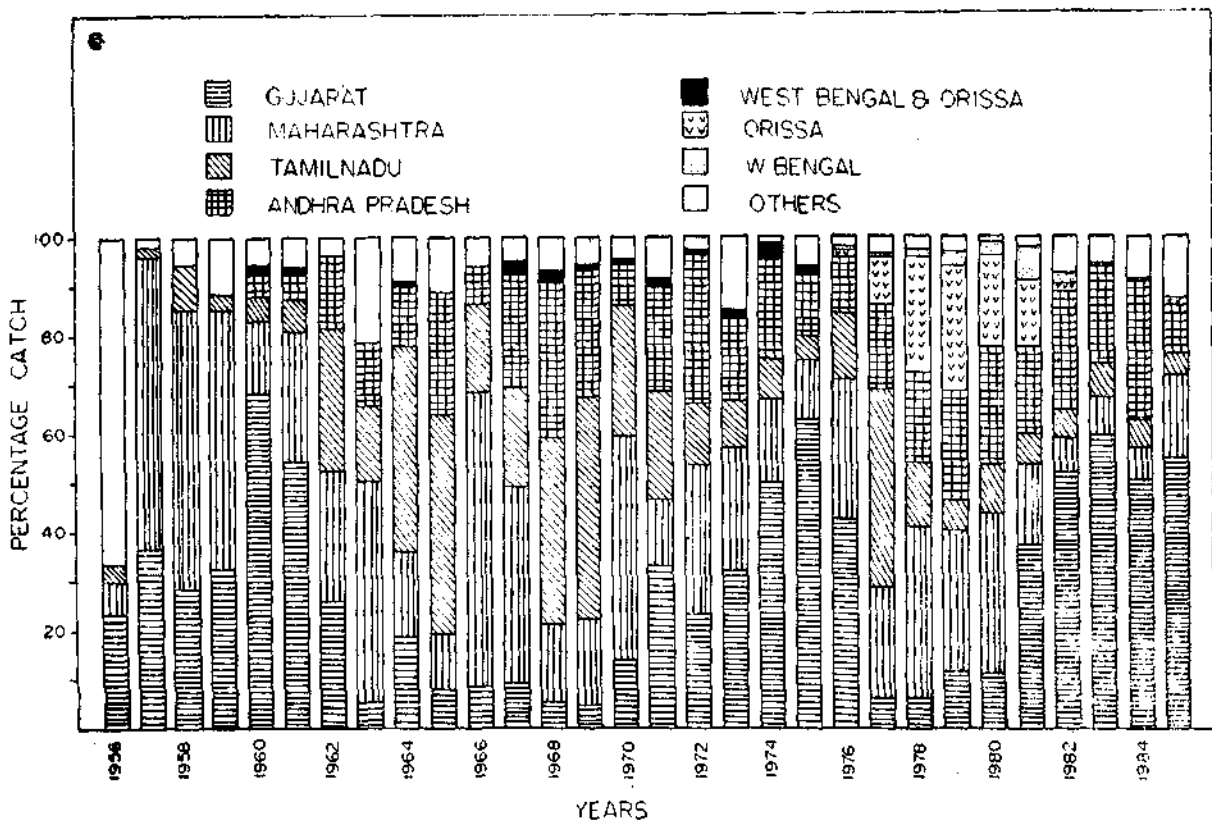

Fig. 2. State-wise percentage catch of polynemids during 1956-1985.

CATCH DISTRIBUTION

It was reported that between 1956 and 1965 nearly 80% of the polynemid catch was coming from Gujarat and Maharashtra along the north west coast (Kagwade, 1968). However the data showed that it was true till 1961 only (Fig 2) and thereafter the catches and percentage catches began to drop reaching 337 t and 19.26% in 1965. The catch improved in 1966 recording 3158 t which formed 68.71%. It further fluctuated till 1970 and steadily increased to record a catch of 10460 t and a percentage catch of 74.48 in 1975. The years after 1977 when the catch was reduced to 1130 t forming 28.76% the catch steadily improved year after year and reached the value of 6505 t forming 71.8% indicating that the fishery in north west coast is towards improvement. The status of Gujarat and Maharashtra appeared to be equal as far as polynemid catches were concerned because in some years the catches were more in Gujarat and in other in Maharashtra. However, the catches were improving and were very good in Gujarat from 1981 onwards while they were poor in Maharashtra during the same period, but showed a sign of improvement in 1985 with a yield of 1527 t forming 16.86%.

Along the east coast, polynemid catches improved with the passage of time. Tamil Nadu and Andhra Pradesh yielded good polynemid catches which in some years excelled those either in Gujarat or Maharashtra. Till 1975 data on catches of West Bengal and Orissa were combined. Catches forming less than 1% in the total landings were not shown in Fig. 2. Fluctuations in the catches and percentage catches were noticed in all the states but the variations were not as wide as in the north west coast. In Tamil Nadu maximum catch of 1944 t was in 1977 and the minimum of 236 t was in 1981. The highest percentage catch of 45.37 was in 1965 and it was also the highest among all states for that year. The minimum of 1.92% for this state was in the very beginning period, in 1957. In Andhra Pradesh the catches ranged between 298 t in 1964 and 2231 in 1974 while the percentage catch ranged between 4.54 in 1960 and 31.96 in 1968. The combined catches of West Bengal and Orissa from 1960 to 1975 were

very poor, ranging between 3 and 313 t and between 0.06% and 3.63%. From 1978 onwards, the catches were recorded separately for these two states. The Orissa coast appeared to yield better polynemid catch than the West Bengal which can be graded as poor. Between 1978 and 1980 Orissa landed over 1100 t annually, the maximum being 1491 t forming 25.67% which is far above the catches at Gujarat or Maharashtra during their lean years. The south western coast covering Goa, Karnataka was very poor for polynemids.

SPECIES CONTRIBUTING TO THE FISHERY

The polynemid fishery along the north west coast was comprised of 3 species as mentioned earlier. *P. indicus* and *E. tetradactylum* growing to large sizes cost more than Rs. 100/- per piece and *P. heptadactylus* Rs. 6-7 per kg. Along the east coast the fishery of *P. indicus* exists near Madras and of *E. tetradactylum* in Orissa and West Bengal. In addition to these *P. heptadactylus* and *P. sextarius* contribute to the fishery here. At Mandapam *P. microstoma* is another species adding to the list. In the Hooghly estuarine system *P. paradiseus* contributes to the polynemid fishery. The last 4 mentioned species do not grow to large size.

LIFE HISTORY

Of the 9 species of polynemids found in India, the biology of *P. indicus* and *P. heptadactylus* in full, of *E. tetradactylum* and *P. paradiseus* in parts and some informations scattered here and there on other species are available. Except *E. tetradactylum* which is conditioned for estuarine as well as marine environment, all other species are marine in habitat. *P. indicus* and *E. tetradactylum* which grow to large sizes, on the north west coast are traditionally caught by gill nets. 'Waghra' (Deshpande, 1962) is a special gill net used to capture *P. indicus*. The polynemids are also captured incidentally in the bag nets and seine nets operating along different parts of the coasts and also in trawl nets. In the Hooghly estuarine system *P. paradiseus* is captured by long lines with 200 to 500 hooks of No. 16 and 17 with prawns as bait (Jones & Menon, 1953).

P. indicus is a major species contributing to the bulk of polynemid fishery of the country (Kagwade, 1968 and 1970). Preferring shallower waters up to 45 meters, the species is recorded in depths upto 70 meters (Rao *et al.*, 1968). It has a specific size distribution along the north west coast. The young ones of the sizes 30-75 cm. called 'Chelna' are found in the shallower waters of Dwarka and Kutch (Kagwade, 1968 a). At this stage they are all immature and aged from 1 to 3 years. After they mature in the fourth year, they move towards shore and enter Gulf of Kutch and Gulf of Cambay for spawning. Of the 2 spawning seasons April-June and October-December (Nayak, 1959), the former is the major one. It is during this major spawning migration that the gill netters of Gujarat and of the fishing villages Satpati and Dahanu in Maharashtra go towards Gulf of Kutch and Gulf of Cambay respectively for fishing. The specimens caught at this time are mostly mature in the beginning and later on, are in running condition followed by a number of spent ones. Though specimens as large as 142 cm is on record the size range of *P. indicus* caught by 'Waghra' net is generally 84 to 110cm and the dominant size group is 91-100 cm (Kagwade, 1970) and the individuals weigh over 18 kg. (Kagwade, 1966). Another important aspect of biology of this species is that it is a regular hermaphrodite with gonochoristic ovotestis (Kagwade, 1974). When the ovary is active, the testicular part is dormant and is difficult to see through the naked eyes. When the testis is active, a careful observation reveals ovarian part in immature condition running side by side of the testis from one end to the other. The alternate development and functioning of ovary and testis is repeated throughout. A fecund of 5,611,650 ova in this species has been recorded by Karekar and Bal (1960).

P. heptadactylus growing to a small size has its juveniles inhabiting the inshore waters. Its adults are found in appreciable quantities in the trawler landings operating upto 80 meters (Kagwade, 1968 b). This species is also a hermaphrodite (Kagwade, 1967) and is found to breed throughout the year with two peak periods during March-June and August-November (Kagwade 1970). Maximum of 61,943 eggs has been recorded as the fecundity in this species.

E. tetradactylum which grows to a recorded size of 180 cm. matures comparatively very early at 36-39 cm (Kagwade, 1970), a size nearly half of that when *P. indicus* matures. This species also records 2 peak spawning periods (Karandikar and Palekar, 1950). The findings of Jones and Sujansingani (1954) that there was total absence of females in the III-IV stages of maturity in the Chilka lake suggest that this lake may be a nursery for *E. tetradactylum*. The availability of females with oozing ova and their larvae and post larvae in the creeks around Bombay indicate that this species breeds in the inshore waters.

Jones and Menon (1953) observed only juveniles of *P. paradiseus* upto 70 cm and adults above 12.5 cm and later on David (1954) too found only the juveniles upto 8 cm and adults above 15.0 cm in the Hooghly river while the sizes between these 2 lengths did not appear here at any time of the year. Hida (1967) reported the sizes between 8 and 14.3 cm in the Bay of Bengal along the Burmese coast at a depth between 15 and 27 meters. It appears from this that *P. paradiseus* also demonstrates a specific size distribution, similar to that noticed in *P. indicus*. Just as the shallow waters of Dwarka and Kutch are the nursery grounds for *P. indicus*, the shallow grounds along the Burmese coast may be the nursery grounds for *P. paradiseus*. After maturation they may be moving towards Hooghly river for spawning.

DISCUSSION

The polynemid fishery on the north west coast showed a decline of alarming nature in the sixties while in the years that followed it improved on the east coast. The bulk of the fishery on the north west coast was formed by *P. indicus*. When the trawling started especially, in the nursery grounds of Dwarka in fifties and later on of Kutch in sixties, large quantities of medium sized juveniles in their I to III years measuring upto 75 cm and weighing upto 7 kg., were landed. This species attains maturity only in the fourth year. The fecundity of over 5.5 million eggs has been estimated in some individuals. Being a gonochoristic hermaphrodite, the female phase is restricted to nearly half the time that a normal female would take

if it were to exist independently. The heavy exploitation of the juveniles, late maturity in the fourth year and restriction in reproducing progeny brought about by the hermaphroditic character, must have all been the combined force for the decline of polynemid fishery along this coast.

Concentration of trawling in late sixties and seventies for prawns which by then were under great demand because of their export potential, the trawling for 'Dara' was forgotten and this must have helped in the revival of its fishery accompanied by natural fluctuations during seventies and eighties. In the absence of any meaningful catch of polynemid by the trawlers, the improved polynemid catch is only due to the traditional fishermen fishing by the indigenous methods during the spawning migration of the species. The gear used by them is highly selective and the size of species caught in it is mostly between 91 and 100 cm. This helps the bigger and smaller individuals left for propagation. Since the fishery is of very small magnitude, the species can be conserved by restricting to the traditional way of fishing and prohibiting trawling in the nursery grounds. Further the traditional fishermen fish during 3-4 months in a year and this itself acts as a good enough management measure for this fishery.

ACKNOWLEDGEMENT

The author expresses thanks to Shri J. D. Sarang, Technical Assistant for helping in the preparation of the figures.

REFERENCE

- ANONYMOUS 1969. Marine fish production in India, 1950-1968. *Bull. Cent. Mar. Fish Res. Inst.* No. 13 : 1-144.
- ANON 1979. Trends in total marine fish production in India - 1978. *Mar. Fish. Infor. Serv. T & E Ser. No. 9* : 7-22.
- ANON 1981. Trends in marine fish production in India - 1981. *Mar. Fish. Infor. Serv. T&E Ser. No. 41* : 1-33.
- ANON 1983 Trends in marine fish production in India - 1982-83. *Mar. Fish. Infor. Serv. T & E Ser. No. 52* : 1-21.
- ANON 1986 Marine fish production in India - 1983-84 and 1984-85. *Mar. Fish. Infor. Serv. T & E Ser. No. 67* : 1-79.
- DESHPANDE, S. D. 1962. An account of 'Dara' *Polydactylus indicus* (Shaw) fishery of the Bombay coast with particular reference to the fishing method by bottom drift nets. *Indo-Pacif. Fish. Councl.* 62. Tech. 26, 10th session, Seoul, Korea : 1-20.
- DAVID 1954. A preliminary survey of the fish and fisheries of a five mile stretch of the Hoogly river near Barrackpore. *Indian J. Fish.* 1 : 231-250.
- HIDA, T. S. 1967. The distribution and biology of polynemids caught by bottom trawling in Indian seas by the R/V Anton Brunn, 1963. *J. Mar. Biol. Ass. India*, 9 (2) : 281-299.
- JONES, S. AND P. M. G. MENON 1953. Notes on the breeding habits and developmental stages of some estuarine fishes. *J. Zool. Soc. India* 5 (2) : 255-267.
- JONES, S. AND K. H. SAJANSINGANI 1954. Fish and fisheries of the Chilka lake with statistics of fish catches for the year 1948-50. *Indian J. Fish.* 1 : 256-343.
- KAGWADE, P. V. 1966. *Polydactylus indicus* (Shaw) in the landings by bull trawlers operating in Bombay and Saurashtra waters during 1956-63. *Indian J. Fish.* 12 (2) : 459-472.
- KAGWADE, P. V. 1967. Hermaphroditism in a teleost, *Polynemus heptadactylus* Cuv. & Val. *Indian J. Fish.* 14 : 187-197.
- KAGWADE, P. V. 1969 a. Polynemid fishery resources of India. *Symposium on the living resources of the seas around India*. Special publication, CMFRI : 425-433.
- KAGWADE, P. V. 1968 b. The fishery of *P. heptadactylus* Cuv. and Val. in India. *Proc. Indo. Pacific. Fish councl.* 13 (III) : 384-401.

- KAGWADE, P. V. 1970 Maturation and spawning in *Polynemus heptadactylus* Cuv. & Val. *Indian J. Fish.* 17 : 76-89.
- KAGWADE, P. V. 1970 The polynemid fishes of India. *Bull. Cent. Mar. Fish. Res. Inst.* No. 18 : 1-69.
- KAGWADE, P. V. 1974 Sexuality in *Polydactylus indicus* (Shaw). *Indian J. Fish.* 21 (2) : 323-329.
- KARANDIKAR, K. R. AND V. C. PALEKAR 1950 Studies on the ovaries of *Polynemus tetradactylus* (Shaw) in relation to its spawning habits. *J. Univ. Bombay* 19 (3) : 21.
- KAREKAR, P. S. AND D. V. BAL 1960 A study on maturity and spawning of *Polydactylus indicus* (Shaw). *Indian J. Fish* 7 (1) : 147-164.
- NAYAK, P. D. 1959 Some aspects of the fishery and biology of *Polydactylus indicus* (Shaw). *Indian J. Fish* 6 (2) : 280-297
- RAO, K. VIRABHADRA. K. DORAIRAJ, P. V. KAGWADE AND D. M. PUNWANI 1968 Results of the exploratory fishing operation of the government of India vessels at Bombay base for the period 1961-67. *Proc. Indo-Pacific Fish. Coun.* 13 (III) : 402-430.

AN ASSESSMENT OF THE BOTTOM-TRAWL FISHERY RESOURCES OF THE NORTHEAST COAST OF INDIA

S. Reuben, G. Sudhakara Rao, G. Luther, T. Appa Rao, K. Radhakrishna,
Y. Appanna Sastry and G. Radhakrishnan
*Visakhapatnam Research Centre of Central Marine Fisheries
Research Institute, Visakhapatnam - 530 003.*

ABSTRACT

An overview of the bottom trawl fishery resources of the continental shelf of the northeast coast (lat. 15° N-21° N and long. 80° E-88° E) has been attempted based on data collected from the exploratory fishery surveys conducted by the Govt. of India fishing vessels during 1961-1985. The 'swept-area' method has been employed to estimate the standing stock, and 60% of this has been reckoned as the potential yield. The catch rates in the shelf region ranged between 1 kg/hr in square 17-33 C1 and 377 kg/hr in squares that yielded 150 kg/hr or more are distributed widely both in the inshore and offshore grounds. The potential yield estimates for the area explored varied between 0.83 t/km² in 20° N-87° E and 3.37 t/km² in 19° N-35° E.

A potential yield of 150 919 t has been estimated for the 81.684 km² area for the shelf and adjacent areas along the northeast coast with the State wise break up as: West Bengal 24 121 t, Orissa 52,065 t and Andhra Pradesh 74,733. Depth-wise potential yield in the shelf area and beyond are also given. It is pointed out that demersal fish catches off West Bengal and Orissa could be increased with increased exploitation. It is observed that sharks and skates, rays, catfishes, mackerels, threadfin breams and jacks are underexploited at present and that lizard fishes and croakers have already reached the optimum level of exploitation. Current knowledge of bottom trawl fishery resources of the shelf area of the northeast coast has been reviewed, and the factors responsible for the variations in the potential yields estimated by various authors have been discussed.

INTRODUCTION

Exploratory bottom trawling operations are being conducted by the Fishery Survey of India (FSI) since 1960 with intensive coverage along

the northeast coast of India: Off West Bengal, Orissa and Andhra Pradesh, between latitudes 15°N to 21°N and longitudes 80° E to 88°E. Different aspects of the results of these exploratory trawling operations have been reported

various authors from time to time (Naumov, 1961; Shariff, 1961; Poliakov, 1961 & 1962; Borisov, 1962; Sekharan *et al.*, 1973; Krishnamoorthi, 1973 and 1976; Josph *et al.*, 1976; Anon, 1980; Antony Raja, 1980 and Sivaparakasam, 1987). These accounts, however, were limited to short periods of time covering small areas and a few vessels, and some times to one or two specific resources. Stimulated by the results of the exploratory fishing operations, the private entrepreneurs have embarked on commercial fishing through the introduction of small sized boats using shrimp trawl with an operational range of about 35 km. Mexican type of large trawlers with cold storage facility which could make 20-30 days voyage covering vast areas have started fishing on a commercial scale in the area since 1978. With the concentration of over 100 such large trawlers, Visakhapatnam has come to stay as a very important fishing harbour in our country. Roychowk, Paradeep and Kakinada are the additional bases with facilities to operate small sized shrimp trawlers along the northeast coast. Bhavanapadu and Nizampatnam are fast emerging as minor fishing harbours along the Andhra coast.

In view of the ever increasing fishing effort being expended by the large trawlers as well as the small mechanized boats along this coast, it has become imperative to understand the present status of the bottom trawl fishery resources in order to formulate policies for proper management of the resources. The present account provides a comprehensive overview of the past 25 years, since 1961, by various vessels of the FSI in different areas of this vast region.

MATERIAL AND METHODS

This report is based on the analysis of data collected during the exploratory bottom trawling operations of the FSI vessels based at Visakhapatnam during the period 1961-1985 over an area of 81,684 km² extending from Sunderbans in the north (21°N) to Ramayapatnam in the south (15°) and projecting 20-120 km towards the continental slope (Fig. 1 & 2). In all 10 vessels were involved in exploratory fishing

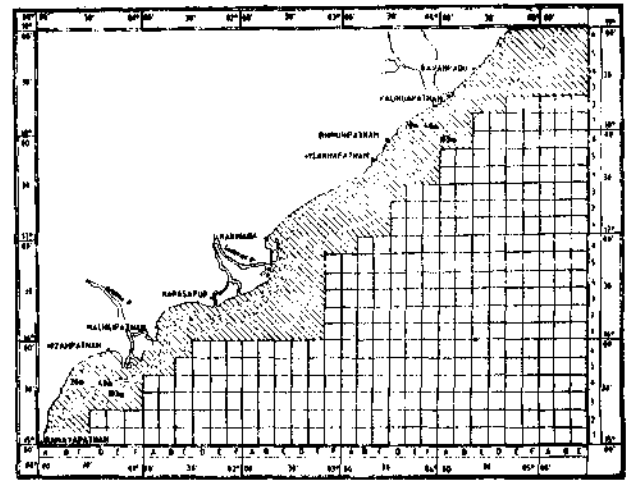

Fig 1 Areas Explored (Hatched) off Andhra Pradesh

Fig. 1 : Areas explored (hatched) off Andhra Pradesh.

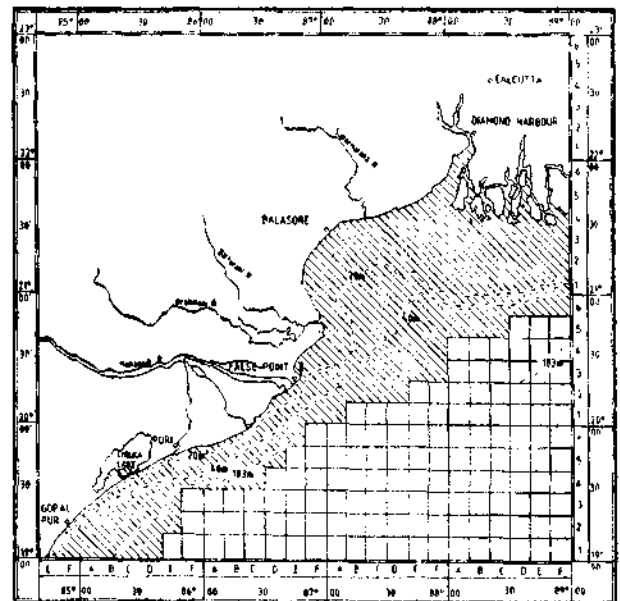

Fig 2 Areas Explored (Hatched) off Orissa and West Bengal

Fig. 2 : Areas explored (hatched) off Orissa and West Bengal.

over the period. But only 5 of them, namely, *M. T. Ashok*, *M. V. Champa*, *M. V. Meena Shodhak*, *M. V. Meena Jawahar* and *M. F. V. Matsya Shikari* are considered in the present study. The remaining five vessels, namely, *M. T. Pratap*, *M. T. Gudjon*, *M. V. Sea Horse*, *M. V. Sagar Kumari* and *M. F. V. Matsya Darshini* expended negligible effort in bottom trawling and hence not considered. The vital statistics, including the performance, of the first five vessels are presented in Table 1,

TABLE 1

Vessels and gears employed for exploratory bottom trawling off northeast coast of India

Particulars of vessel	M. T. Ashok	M. V. Champā	M. V. Meena Jawahar	M. V. Meena Shodak	M. F. V. Matsya Shikari
OAL in m	25.4	14.3	17.5	17.5	39.5
GRT	91.7	34.5	56.8	56.8	352.5
BHP (rated)	240	165	200	200	1740
Gear	Fish otter trawl	Fish otter trawl	Fish otter trawl	Fish otter trawl	Fish otter trawl
Length of head rope (m)	15	14	24	24	34
Cod-end mesh size (mm)	40	30	50	50	50
Period of operation	1961-'70	1961-'71	1973-'79	1972-'81	1980-'85
Area surveyed	16°-20°N	17°-18°N	15°-19°N	15°-19°N	15°-20°N
Hours spent in trawling	6259	6983	4366	4065	4276
Catch in t	899	687	369	303	688
Cph in kg	143.62	98.4	84.5	74.5	160.9
Fishing power	1.70	1.16	1.00	0.88	1.90

OAL = Overall length; GRT = Gross registered tonnage; BHP = Break horse power
Cph = Catch per hour of trawling.

On board the vessel, the catches were broadly categorised into six groups, namely, 1) sharks & skates 2) rays 3) catfishes 4) prawns 5) miscellaneous small and 6) miscellaneous big. The scientists of the Visakhapatnam Research Centre of C. M. F. R. I. further subdivided these groups into genera and species by collecting representative samples. In all, the following 17 major groups/species were considered for this purpose: 1) sharks & skates 2) rays, 3) catfishes, 4) mackerel, 5) ribbon-fishes, 6) silverbellies, 7) threadfin breams, 8) croakers, 9) lizard fishes, 10) drift fish, 11) whitefish, 12) grunters, 13) jacks (Carangids), 14) pomfrets, 15) goat fishes, 16) 'other perches' and 17) miscellaneous fishes (Table 2). Tunas, threadfins, seerfishes, sickle fishes, red snapper, barracudas, silver breams and such other large varieties were clubbed under 'other perches', where prawns, crabs, lobsters, cephalopods, soles, flatfishes, clupeoids etc, comprised the miscellaneous fishes.

The entire region of exploration of 81,684 km² has been subdivided into 10' x 10' squares, each of 343 sq km (18.53 x 18.53 km). These squares were designated numerically

(1-6) along the latitude and alphabetically (A-F) along the longitude. Each square is indicated by its latitude-longitude and the coordinates separated by an oblique stroke. Each ten minute square is taken as the unit grid to demarcate the abundance of the resources. Catch and catch rate (cph) are expressed in kg, and effort in hours. The data from each vessel were analysed square-wise for the entire period of operation. The effort put in by the different vessels has been standardized instead of interpreting the data vessel-wise as was done by the previous authors.

M. V. *Meena Jawahar*, among the five vessels, was taken as standard as she operated during the middle part of the period under study, and was intermediate in OAL among the vessels employed in the survey. In view of the wide variability in design, capability and efficiency of the vessels and nets, fishing power of different vessels/nets could not be standardized based on the length or horse power of the vessels. Hence, the cph of the vessels based on their catch and effort for the entire period has been taken into account to compute their relative fishing power. Thus, considering the fishing power of *M. T. Jawahar* as 1, the

relative fishing powers of *M. T. Ashok*, *M. V. Champa*, *M. V. Meena Shodhak* and *M. F. V. Matsya Shikari* was estimated as 1.70, 1.16, 0.88 and 1.90 respectively. Based on these estimates the effort put in by each vessel was standardized. For instance if *M. T. Ashok* operated in a square for 5 hours, the standard effort of this operation works out to (5 x 1.7) 8.5 hours. Likewise if *M. V. Meena Shodhak* operated for 5 hours in a square the standard effort becomes (5 x 0.88) 4.4 hours. In this

manner the entire fishing operations by different vessels in each square have been integrated to obtain the total fishing effort expended, and the catch rate arrived at. Depending on the cph values for the total trawl catches the squares were categorized as very poor (< 20 kg), poor (21-50 kg), moderate (51-100 kg), rich (101-150 kg) and very rich (> 150 kg) (Figs. 3 and 4). For individual groups of fishes, however, a lower scale was adopted eg. very poor (< 1 kg), poor (1-5 kg) moderate (6-10 kg), rich (11-20 kg) and very rich (> 20 kg).

Data from squares, where the total effort put in was 5 hours or less have not been considered in this study.

Standing stock in each square is estimated by the 'swept area' method (Gulland, 1965). The size of the standing stock (B) is obtained from the relationship :

$$B = \frac{C/F.A}{a \cdot X_1}$$

where,

C/F = the mean catch per unit of effort (cph),

A = the area of exploitation

a = the area swept by the gear during one unit of effort (one hour)

X_1 = the proportion of fishes in the path of the net which are actually retained by the net. A value of $X_1 = 0.5$ as proposed by Pauly (1979 and 1983) for Southeast Asian waters is adopted here.

The bottom surface area (a) swept by the gear during a unit of effort is computed from the equation :

$$a = t \cdot v \cdot h \cdot X_2$$

where,

v = speed of the vessel while trawling

t = time spent for trawling

h = length of the trawl head rope

X_2 = fraction expressing the width of the area swept by the gear, which is a function of the length of the head rope (h). The value of X_2 ranging between 0.4 and 0.66 has been employed in Southeast Asian waters with 0.5 as the best compromise (Pauly 1979). Hence X_2 is taken as 0.5 in this analysis.

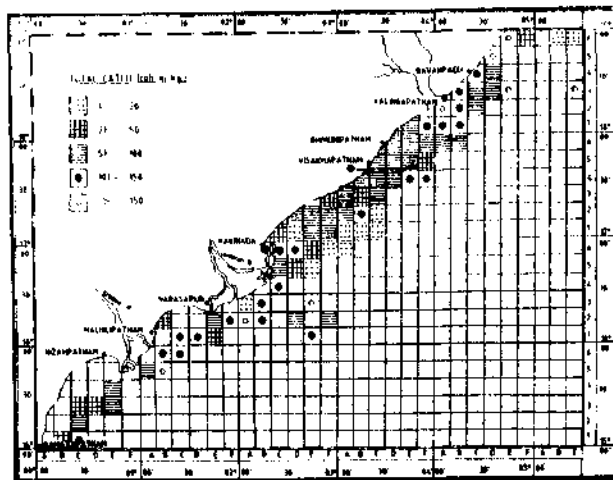

Fig. 3: Distribution of catch rates for the total catches in the explored areas off Andhra Pradesh.

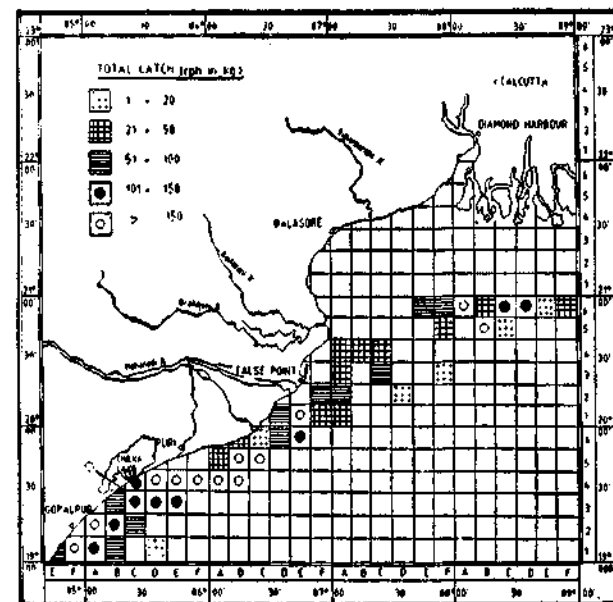

Fig. 4: Distribution of catch rates for the total catches in the explored areas off Orissa and West Bengal.

Fig. 4: Distribution of catch rates for the total catches in the explored areas off Orissa and West Bengal.

For computing the area swept (a) the following values have been adopted : $t =$ one hour, $v = 2.5$ km, $h = 24$ km and $x_2 = 0.5$. Thus the area swept per unit time works out to 0.06 km².

For computing standing stock (B) the values adopted are : $C/F =$ mean cph, $A =$ area of one square being 343 km², $a = 0.06$ km² and $x_1 = 0.5$.

The values of standing stock for the different $10' \times 10'$ squares surveyed have been added up and the average value for one square was obtained. Based on this, the standing stock for the corresponding $1^\circ \times 1^\circ$ area along the north east coast surveyed has been estimated. Thus the total value of standing stock for the entire region was obtained by adding values calculated for different $1^\circ \times 1^\circ$ trawled during the period under report. The terms 'square' and 'area' used in the text refer to $10' \times 10'$ squares and $1^\circ \times 1^\circ$ squares respectively.

The above procedure has been adopted to estimate the standing stock of the bottom trawl resources as a whole as well as for the individual groups. The potential yield is reckoned as 60% of the standing stock.

The catch figures of the various groups of fishes mentioned in the text as 'present landings' refer to the landings by all the craft and gear mechanised as well as artisanal.

Three depth zones viz, less than 40 m, 40m-180m and beyond 180 m are considered for the depth-wise estimation of potential yields. The latitude-longitude zones of $15^\circ-80^\circ$ to $18^\circ-85^\circ$, $19^\circ-84^\circ$ to $20^\circ-88^\circ$ and $21^\circ-86^\circ$ to $21^\circ-88^\circ$ have been considered to represent the fishing grounds off Andhra Pradesh, Orissa and West Bengal respectively for the purpose of the present analysis. The data from the explored area in the shelf have been extrapolated to the entire shelf area.

RESULTS

Effort

Effort expended by different vessels varied widely. The quantum of effort expended in different squares ranged from 1.1 trawling hrs in 19-85/A3 to 8640.4 trawling hrs in 17-83/C5.

Out of the 160 squares explored, 24 squares were fished for less than 5 hours, 18 squares for 5.1-10 hrs, 47 squares for 10.1-50 hrs, 20 squares for 50.1-100 hrs, 4 squares for 100.1-1000 hrs and 5 squares for more than 1000 hrs.

Catch rates

The catch rates for the total resource (Figs. 3 & 4) in different squares varied from 1 kg (16-82/E5, 17-83/C1) to 377 kg (20-88/B5). The categorisation of squares in terms of abundance is given below :

Very rich : 15-81/B5, 16-82/A2, E3; 18-84/A2, D5, E6; 18-85/C3; 19-84/C ; 19-85/A2, B4, D4, E4, F4; 19-86/A4, B4, B5, C5, 20-86/E1; 20-85/A6, B5.

Rich : 15-80/C1; 15-81/B6; 16-81/C1, D1, F2; 16-82/B2, B3, B6, C4, C6, D6, 17-83/B2, B5, E4, F4; 18-83/F1; 18-84/A1, B1, B2, B3, C4; 19-85/A1, B2, C3, C4, D3, E3, 19-86/E6; 20-88/C6, D6.

Moderate : 15-80/C2, E3, E4; 15-81/A5; 16-81/E2; 16-82/C5, D2, F2; 17-82/D2, E1, E2, F1, F2; 17-83/A2, A4, B4, C3, C4, C5, C6, D4, D5, D6, E5, E6, F6; 17-84/A6, B6; 18-83/E1; 18-84/C2, C3, D3, D4; 19-84/E1, 19-85/B1, B3, C2; 20-86/D1, F2; 20-87/A2, C3, E6, F6.

Poor : 15-80/B1, C3; 16-81/B2, E1; 16-82/D5, E6; 17-82/C1, F3, 17-83/B3, F5; 18-83/D1; 18-84/F6; 19-86/A5, 20-87/A1, A3, A4, B4, C4, F5.

Very poor : 16-82/A3, E5, F6; 16-83/A6; 17-83/B1, C1, C2; 18-85/B6, C6; 19-85/D1; 19-86/C6; 20-87/D2; 20-88/C5.

Standing stock and potential yield

Standing stock of trawl fishery resources varied from 1740 t in area $17^\circ-84^\circ$ to 33,067 t in area $16^\circ-82^\circ$. The potential yield for each area of 1° latitude and 1° longitude are shown in Table 2. The area surveyed in terms of km², the potential yield of the total resource as well as group wise breakup for each one degree squares are also given in this table. The potential yield varied from 1044 t in area $17^\circ-84^\circ$ to 19840 t in area $16^\circ-82^\circ$ with the total estimate as 1,50,919 t for the entire area of 81,684 sq km. However, potential yield per km² varied from

TABLE
Area-wise potential yields (t) of different

Latitude/ longitude	15-80	15-81	16-81	16-82	17-82	17-83	17-84	1883	18-84
Area in km ²	5848	2133	3882	9711	2519	7058	686	743	5760
Potential yield (t)	7831	5617	6369	19840	3157	10054	1044	1396	12318
Sharks & skates	355	419	497	637	141	386	58	101	677
Rays	203	121	658	1860	139	572	31	100	710
Catfish	551	683	1084	2495	274	2158	256	221	3411
Mackerel	163	134	128	2063	220	452	109	—	82
Ribbonfish	178	22	141	557	6	163	—	17	555
Silverbellies	631	790	248	60	61	420	138	89	365
Threadfinbreems	1254	114	143	485	171	928	7	47	282
Croakers	349	1185	1032	2450	271	1197	76	230	1997
Lizard fishes	2	—	12	89	73	260	78	23	134
Drift fishes	4	114	118	260	228	187	10	25	465
Whitfish	13	19	20	136	32	96	8	39	170
Grunters	18	88	78	548	123	214	4	133	620
Jacks	1436	663	1083	2630	384	437	47	57	755
Pomfrets	387	306	298	465	72	147	8	19	100
Goatfishes	7	25	61	346	77	424	38	54	290
Other perches	820	192	385	707	74	261	11	83	508
Miscellaneous	1440	742	891	3508	891	1752	165	158	1697

0.86 t in area 20°-87° to 3.37 t in area 19°-85°, the average estimate for the entire region surveyed being 1.85 t.

1. **Sharks & skates** : Sharks and skates represented by *Scoliodon* spp, *Carcharhinus* spp, *Sphyrna* spp, *Rhynchobatus* spp, *Rhinobatos granulatus*, *R. variegatus* and *Pristis* spp formed important components of this resource along this coast. The catches were very rich in 19-86°/B4, 20-86°/D1, 20-87°/F 6,

rich in 15°-81°/B5, 15°-81°/C6, 16°-81°/B2, 16°-82°/86, 18°-84°/D5, 19°-85°/A1, 19°-85°/C4, 19°-85°/C4, 19°-85°/F4, 19°-86°/A5, 20°-86°/E1, 20°-87°/E6 and 20°-87°/F5. In the other areas the catch was moderate, poor or very poor (Figs. 5 and 6).

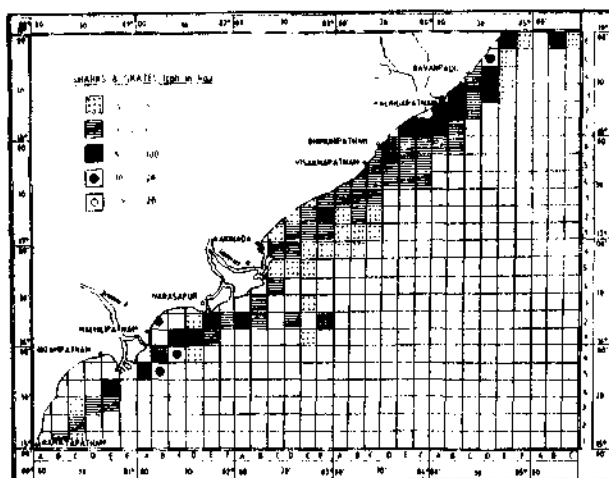

Fig. 5 : Distribution of catch rates for sharks and skates in the explored areas off Andhra Pradesh.

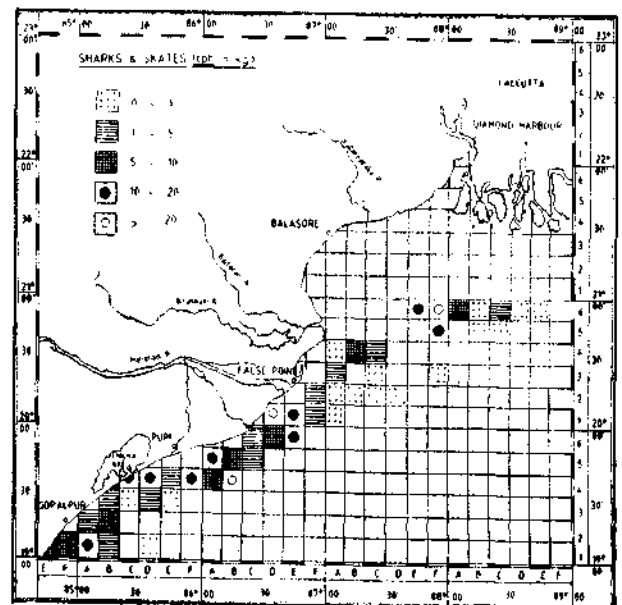

Fig. 6 : Distribution of catch rates for sharks and skates in the explored areas off Orissa and West Bengal

bottom trawl fishery resources.

18-85	19-84	19-85	19-86	20-86	20-87	20-88	11-86	21-87	21-88	Total
4116	730	5733	2879	27-28	9605	2744	686	7899	6174	81684
6607	1867	19312	9447	5987	8295	7157	1518	8511	14092	150919
260	115	759	727	802	1348	136	203	1383	268	9272
—	61	488	204	70	317	124	17	325	245	6237
5719	560	8405	890	371	636	516	94	653	1015	29992
—	—	1561	2890	—	334	1161	—	343	2286	11826
—	20	53	21	27	43	53	7	43	104	1510
—	18	630	32	173	147	—	44	151	—	4541
—	1	730	182	13	402	1032	3	413	2033	8240
44	564	1279	1035	1170	611	1075	298	628	2116	17607
—	9	21	17	14	40	—	4	41	—	817
480	5	416	237	—	26	167	—	26	329	3097
—	12	37	567	52	13	79	13	14	156	1476
—	56	505	409	22	74	36	5	76	71	3080
—	79	914	433	368	310	1718	93	318	3380	15085
—	25	194	122	389	388	56	98	398	110	3522
32	3	52	40	64	20	—	16	21	—	1570
—	115	399	164	463	820	214	118	850	423	6607
72	224	2869	1577	1989	2766	790	505	2828	1556	26440

Potential yield estimates of this group varied from 58 t in area 17°-84° to 1383 t in area 20°-87°. The potential yield for the entire area was estimated as 9272 t. As the present average annual landings is about 7362 t, a further 1910 t of sharks & skates could safely be harvested from this region.

2. Rays: Rays represented by *Dasyatis* spp, *Aetomyleus* spp, *Aetobatus* spp and *Mobula diabolus* formed an important component of

the catches. 'Very rich' grounds for rays were observed in 16°-81°/E1 and 16°-82°/B3. The catch rate was 'rich' in 16°-81°/E2, 16°-82°/B6, 16°-82°/C4, 17°-83°/F4, 18°-84°/B1 and 18°-84°/F6. In the other squares they were moderate, 'poor' or 'very poor' (Figs. 7 and 8).

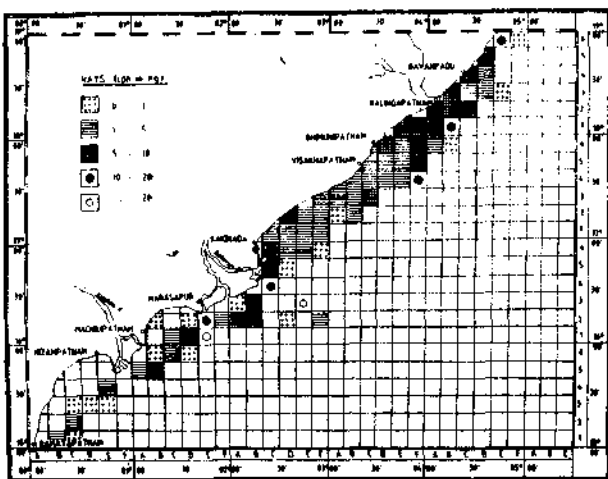

Fig. 7 : Distribution of catch rates for rays in the explored areas off Andhra Pradesh.

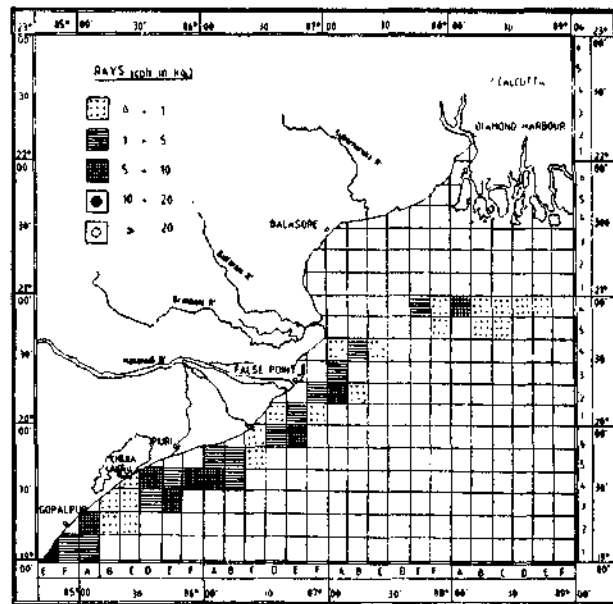

Fig. 8 : Distribution of catch rates for rays in the explored areas off Orissa and West Bengal

Potential yield for the entire region was estimated as 6237 t. It varied from 17 t in 21°-86° to 1860 t in 16°-82°. The present annual landings of rays along this coast is about 2261 t. Hence there is scope for harvesting an additional 3976 t of rays in this region.

3. **Catfishes:** Five species of catfishes viz., *Tachysurus thalassinus*, *T. tenuispinis*, *T. caelatus*, *T. dussumieri* and *Osteogeneiosus milleris* occur in the catches. Only the first two species form the bulk of the landings.

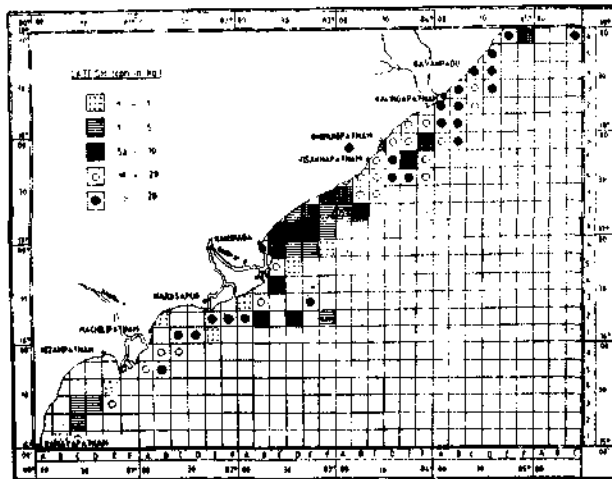

Fig. 9 : Distribution of catch rates for catfishes in the explored areas off Andhra Pradesh.

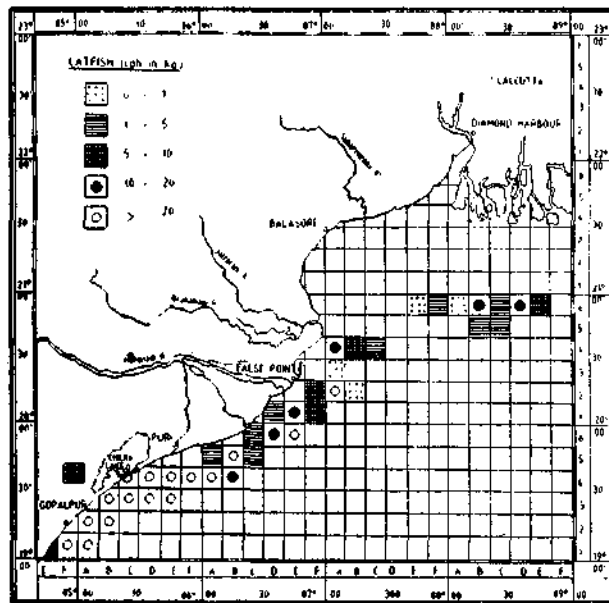

Fig 10 : Distribution of catch rates for catfishes in the explored areas off Orissa and West Bengal.

'Very rich' grounds were observed for catfishes in areas 15°-81°, 16°-81°, 16°-82°, 17°-83°, 17°-84°, 18°-84°, 19°-84°, 19°-85°, and 19°-86°. Catfish catch rates were more than 10 kg in most of squares in the general area explored (Figs. 9 and 10). Potential yield varied from 94 t in 21°-86° to 8405 t in 19°-85°. Potential yield for the entire region was estimated as 29,992 t while the present landings are only 12085 t indicating vast scope for expansion of the fishery for catfishes.

4. **Mackerel :** Mackerel are generally considered to be pelagic species. However, on many occasions, they were caught by these exploratory vessels operating bottom trawls, particularly in the northern latitudes. *Rastrelliger kanagurta* formed the major species contributing to the landings with sporadic occurrence of *R. faughni*. 'Very rich' grounds for mackerel were encountered in 16°-82°/A2, C6, E3; 17°-83°/E5, 19°-85°/A2; 19°-86°/B4, B5, C5; 20°-87°/C3 and 20°-88°/B5 while the grounds were 'rich' in 16°-82°/C5, D6; 19°-86°/A4 (Figs. 11 and 12). Potential yield varied from nil in 18°-83°, 18°-85°, 19°-84°, 20°-86° and 21°-86° to 2790 t in 19°-86°. For the entire region the potential yield was estimated as 11,826 t. The present landings along this coast are only 5065 t per annum indicating ample scope to increase the landings of mackerel. The potential yield value is in itself a gross underestimate since a sizeable portion of this resource occurs in the pelagic realm.

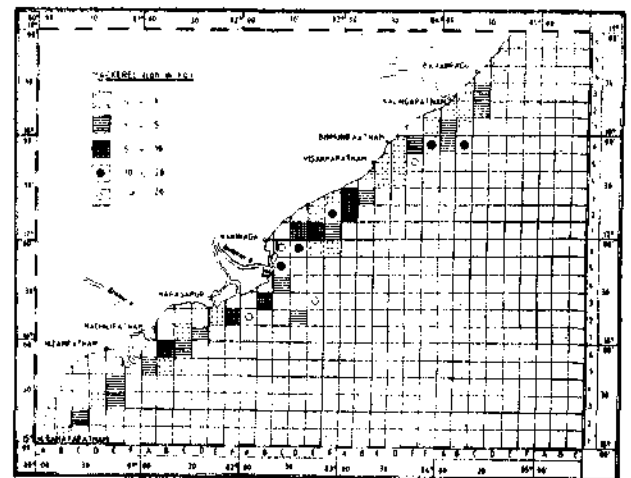

Fig 11 : Distribution for catch rates for mackerels in the explored areas off Andhra Pradesh.

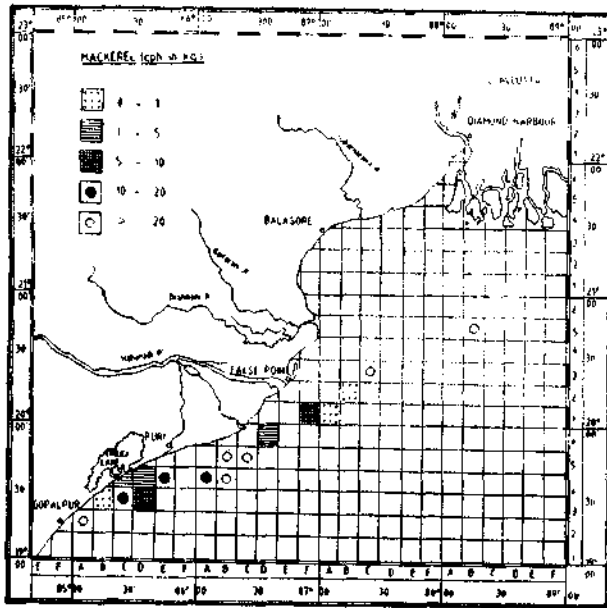

Fig. 12 : Distribution of catch rates for Mackerel in the Explored area off Orissa and West Bengal

Fig. 12 : Distribution of catch rates for mackerels in the explored areas off Orissa and West Bengal.

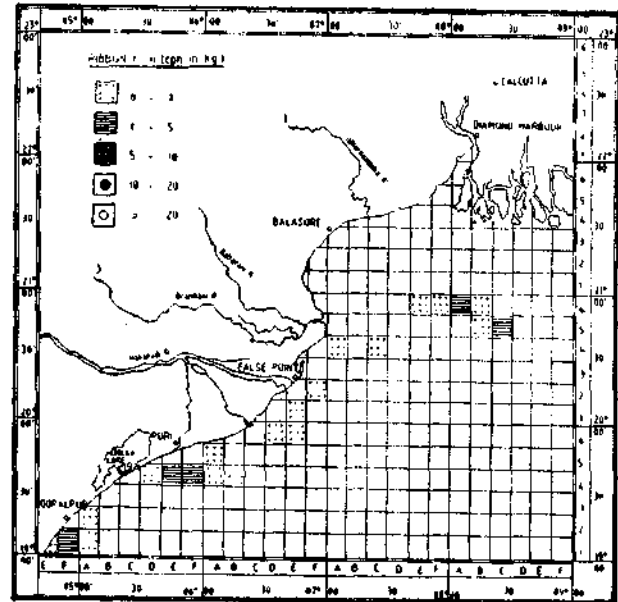

Fig. 14 : Distribution of catch rates for ribbonfishes in the explored areas off Orissa and West Bengal

5. *Ribbonfishes*: *Trichiurus lepturus* formed the major component of the ribbonfish catches with occasional occurrence of *T. russelli*, *Lepturacanthus savala*, *L. gangeticus*, *Eupleurogrammus muticus* and *E. glossodon*. Catch rates were 'poor' in most of the squares probably because of the large mesh of the codend of trawlnet and the low body depth as well as the pelagic habitat of this group. Potential yield varied from nil in 17°-84° and 18°-85° to 557 t in 16°-82° (Figs. 13 & 14).

The potential yield for the entire region was estimated as 1510 t. The present landings are about 8545 t along this coast. The lower potential yield as compared to the actual landings may be due to the pelagic nature of this group.

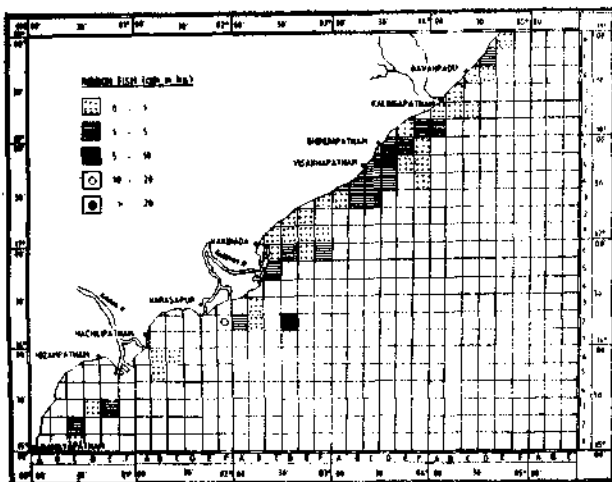

Fig. 13 : Distribution of catch rates for ribbonfishes in the explored areas off Andhra Pradesh

6. *Silverbellies*: *Leiognathus bindus* formed the bulk of the landings and the other species represented in the catches are *L. dussumieri*, *L. leuciscus*, *L. splendens*, *L. equulus*, *Secutor insidiator*, *S. ruconius* and *Gazza minut*. 'Very rich' grounds were observed in squares 15°-81°/A5, B5, 17°-83°/B5 and 19°-85°/D4, and 'rich' grounds in 15°-81°/B6, 16°-82°/C4 and 18°-84°/F2 (Figs. 15 & 16). In the other squares the catch rates were either 'moderate' or 'poor' or 'very poor'. Potential yield varied from nil in 18°-85° 20°-80° and 21°-88° to 790 t in area 15°-81°, and for the entire region it was estimated as 4541 t. It is pertinent here to mention that the nets used are of large mesh at the codend and most of the *Leiognathus species* are small in size and hence escape through the nets. The present estimate could therefore be much lower than the actual potential yield.

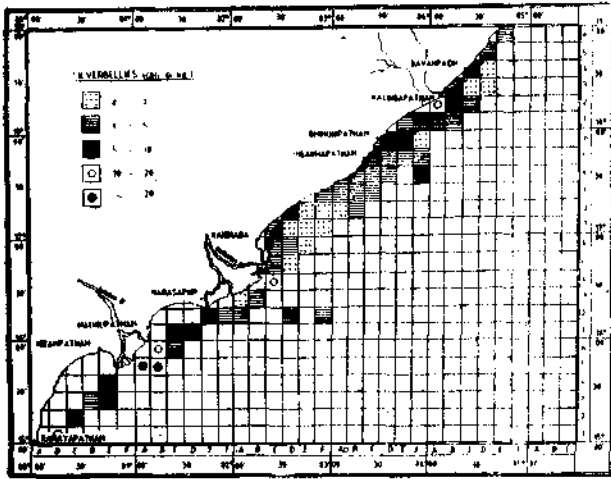

Fig. 15 : Distribution of catch rates for silverbellies in the explored areas off Andhra Pradesh.

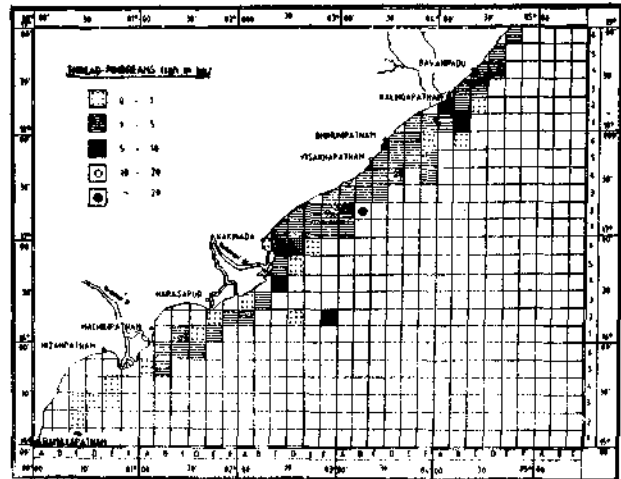

Fig. 17 : Distribution of catch rates for threadfin breams in the explored areas off Andhra Pradesh.

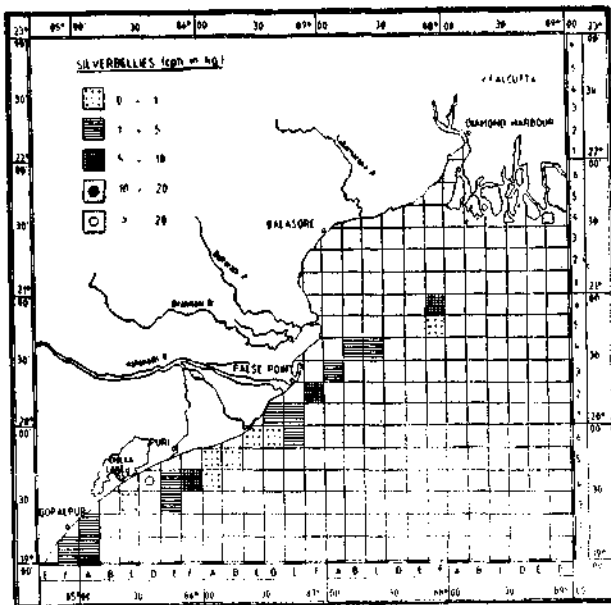

Fig. 16 : Distribution of catch rates for silverbellies in the explored areas off Orissa and West Bengal.

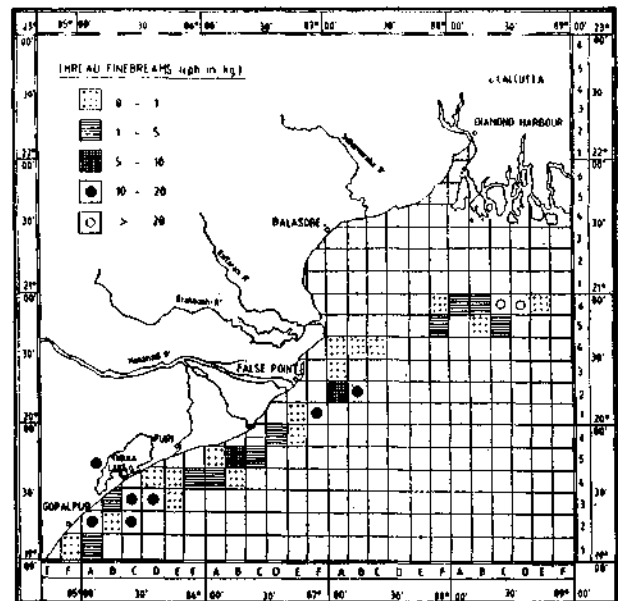

Fig. 18 : Distribution of catch rates for threadfin breams in the explored areas off Orissa and West Bengal.

7. *Threadfin breams: Nemipterus japonicus* and *N. mesoprion* constituted the bulk of the threadfin bream landings while *N. delegeae* and *N. tolu* were observed rarely. 'Very rich' grounds for *Nemipterus spp* were found in 15°-80°/C1, 17°-83°/B2, 20°-88°/C6 and 20°-88°/B6 and 'rich' grounds in 17°-83°/A4; 19°-8°/B4, C2, C3, D3, 20°-85°/F1, 20°-87°/B2, (Figs. 17 and 18). Potential yield varied from nil in 18°-85° to 2033 t in 21°-88° with the total estimate for the entire region at 8240 t. Present landings of threadfin breams along this coast are only

2348 t per annum and another 5892 t can be safely harvested from these grounds.

8. *Croakers*: Although about 20 species of this group were observed in the catches, only *Pseudosciaena aneus*, *P. bleekeri* *P. axillaris*, *P. sina*, *P. diacanthus*, *Johnius carutt*, *J. maculata*, *Sciaena dussumieri* and *Atrorhynchus nibe* were observed in commercial proportions. Very rich grounds for sciaenids were observed in 15°-81°/A4, B5, C6; 16°-81°/C2, F2; 16°-82°/A2, B3, C5, 17°-83°/F, 18°-84°/A2, C4, E6, 19°-84°/F1;

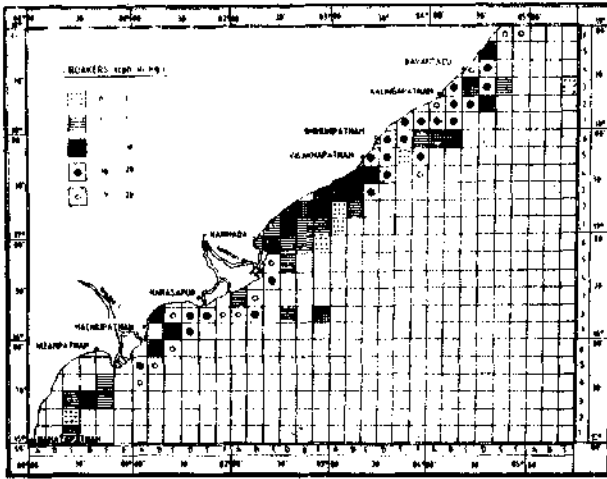

Fig 19 : Distribution of catch rates for croakers in the explored area off Andhra Pradesh.

Fig. 19 : Distribution of catch rates for croakers in the explored areas off Andhra Pradesh.

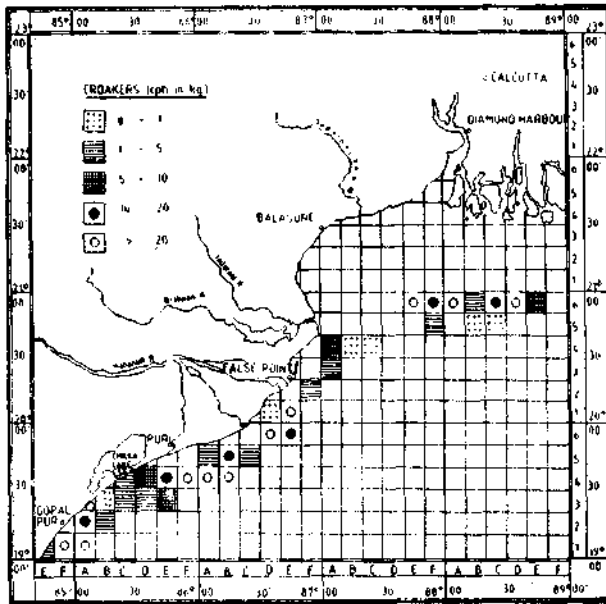

Fig 20 : Distribution of Catch rates for Croakers in the Explored area off Orissa and West Bengal.

Fig. 20 : Distribution of catch rates for croakers in the explored areas off Orissa and West Bengal.

19°-85°/A3, F4; 19°-86°/A4, B4, D6; 20°86°/E1; 20° 87°/E6, 20°-88°/A6 and D6. 'Rich' 'moderate' 'poor' and 'very poor' grounds are represented in Figs. 19 and 20. Potential yield varied from 44 t in 18°-85° to 2450 t in 16°-82° with the total for the entire region estimated as 17607 t. Present landings of sciaenids in this region are about 16,965 t per annum indicating that the resource has almost reached the optimum level of exploitation.

9. *Lizardfishes* : *Saurida tumbil*, *S. undosquamis* and *S. gracilis* constituted the bulk of the landings with occasional occurrence of *S. longimanus*. *Saurida* spp form only a small fraction of the trawler catches. Maximum cph of 9.0 kg was observed 17°-83°/B5. In most of the grounds the cph was less than 1 kg (Figs. 21 & 22). Potential yield varied from nil in 15°-81°, 18°-85°, 20°-88° and 21°-88° to 260 t in 17°-83°, and for the entire region it has been calculated as 817 t while the present landings are about

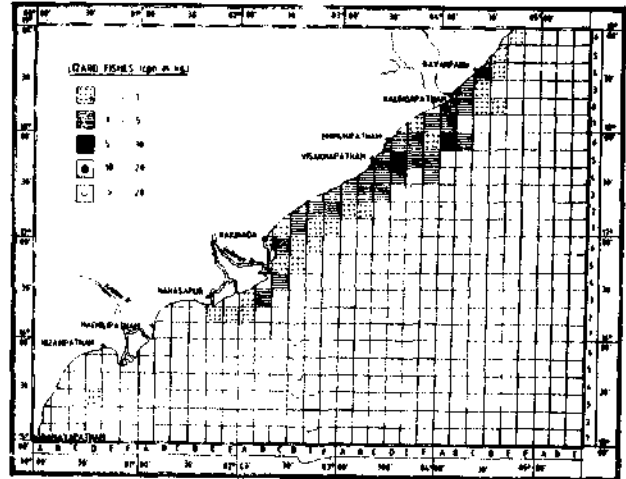

Fig. 21 : Distribution of catch rates for lizardfishes in the explored areas off Andhra Pradesh.

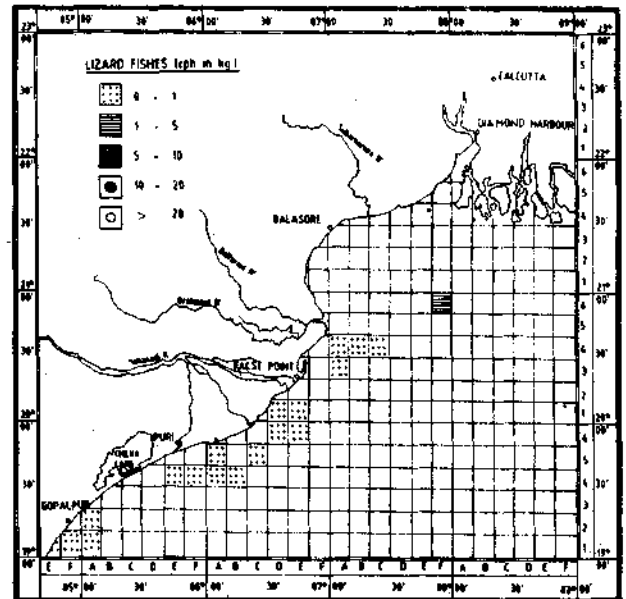

Fig. 22 : Distribution of catch rates for lizardfishes in the explored areas off Orissa and West Bengal.

1141 t. It would appear that the stocks are being fished beyond their potential.

10. *Driftfish*: *Psenes indicus* is the only species of driftfish caught along this coast. 'Very rich' grounds for the species were observed in 19°-86°/C5, 'rich' grounds in 17°-82°/E1, 18°-84°/C3, 19°-85°/A/2 and 20°-88°/A6 and 'moderately rich' grounds in 15°-81°/B5, 16°-82°/C6, 18°-8°/B2, C4, D3, 19-85/B2, C3 and C4 (Figs. 23 & 24). In the other areas either the grounds are 'poor' or 'very poor'. Potential yield varied from nil in 20°-86° and

21°-86° to 480 t in 18°-85° with the estimated total for the entire region being at 3097 t. The annual landings of this species are about 500 t along this coast indicating scope for five fold increase in the landings.

11. *Whitefish*: 'Very rich' grounds for the whitefish *Lactarius lactarius* were observed only in 19°-86°/A4 and 'rich' grounds in 18°-84°/B1, B2, 19°-06°/B5 and 20°-88°/C6 (Figs. 25 & 26). Potential yield from nil in 18°-85° to 567 t in 19°-86° with the total being estimated at 1476 t Presently about 890 t of *L. lactarius* is being

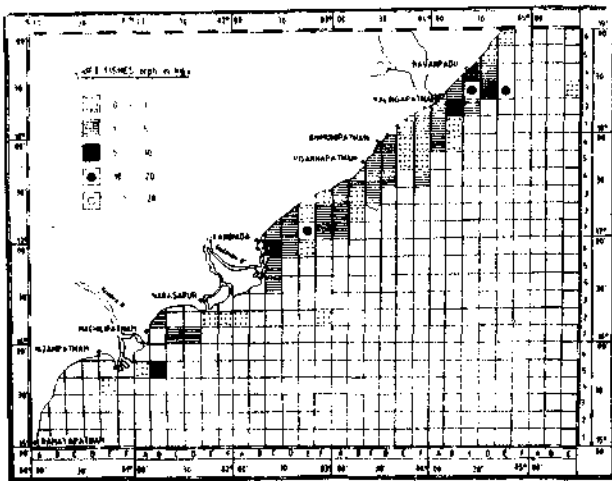

Fig. 23 : Distribution of catch rates for driftfish in the explored areas off Andhra Pradesh.

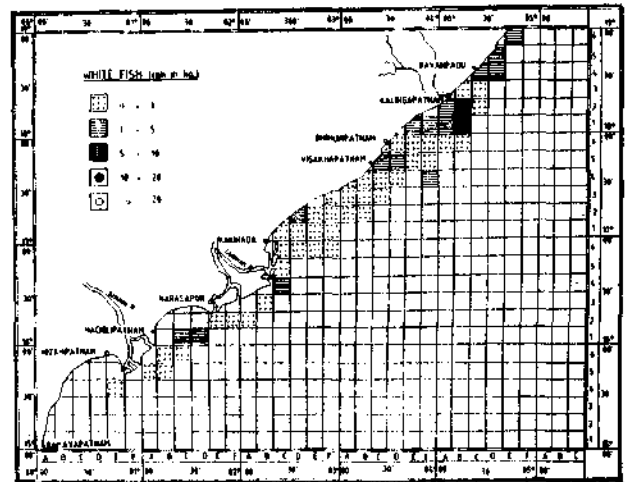

Fig. 25 : Distribution of catch rates for whitefish in the explored areas off Andhra Pradesh.

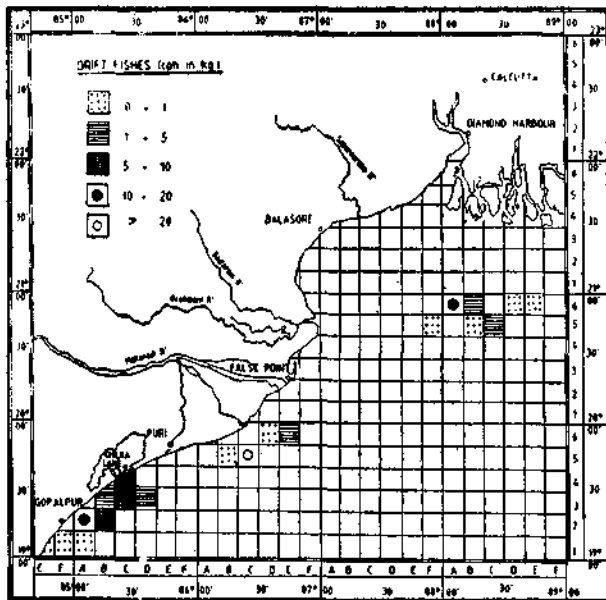

Fig. 24 : Distribution of catch rates for driftfish in the explored areas off Orissa and West Bengal.

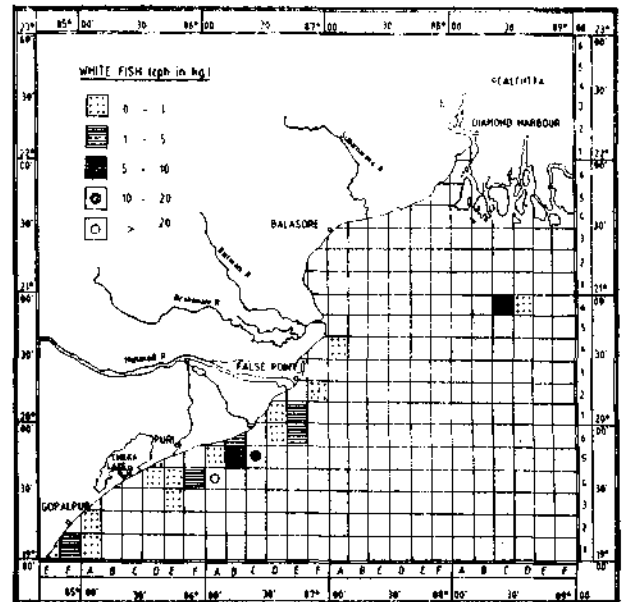

Fig. 26 : Distribution of catch rates for whitefish in the explored areas off Orissa and West Bengal.

landed annually along this coast showing that there is a harvestable supply of 586 t.

12. *Grunters*: *Pomadasys hasta* is the major species of the grunTERS in the landings. *P. maculatus* was also observed in considerable quantities. 'Very rich' grounds were observed only in 16°-82°/B6, 18°-84°/A2 and 19°-86°/B4 were rich (Figs. 27 & 28). Potential yield varied from nil in 18°-65° to 620 t in 18°-84° with an estimated total for the entire region of 3080t. Since data for the present landings of this group are not available separately, it is not possible to state whether the group is over or underfished.

Jacks: Although about 20 species of carangids comprising trevallys, scads, horse mackerel, king fishes, etc., were observed in the catches, only three species viz, *Carangoides malabaricus*, *Decapterus russelli* and *Megalaspis cordyla* contribute to the bulk of the landings. Very rich grounds for carangids were observed in 15°-80°/E3, 16°-81°/C1, D1, F2, 16°-82°/A4, B2, 18°-84°/B2, 19°-85°/C4, 20°-88°/A6 and B5, while the grounds in 15°-80°/C2, C3, E4, 15°-81°/B5, B6, C6, 16-81 A2, C2, E2, 16°-82°/

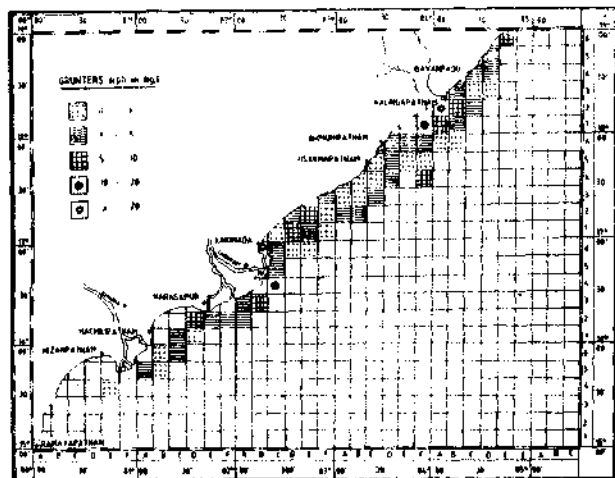

Fig. 27 : Distribution of catch rates for grunTERS in the explored areas off Andhra Pradesh.

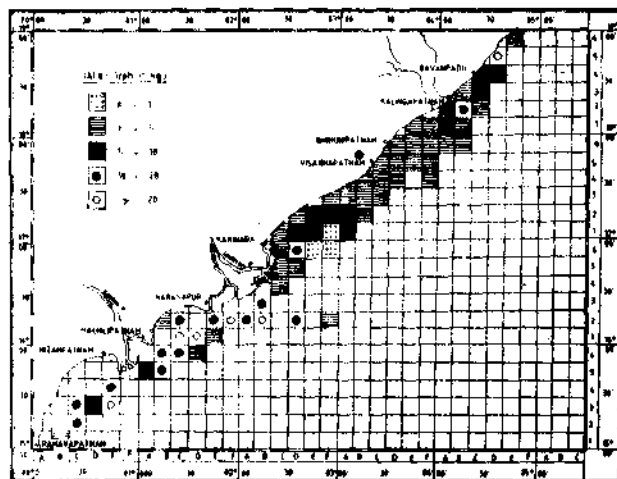

Fig. 29 : Distribution of catch rates for jacks in the explored areas off Andhra Pradesh.

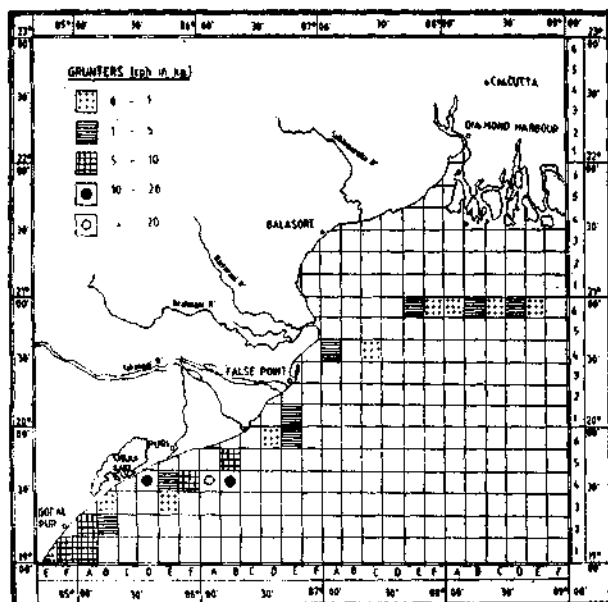

Fig. 28 : Distribution of catch rates for grunTERS in the explored areas off Orissa and West Bengal.

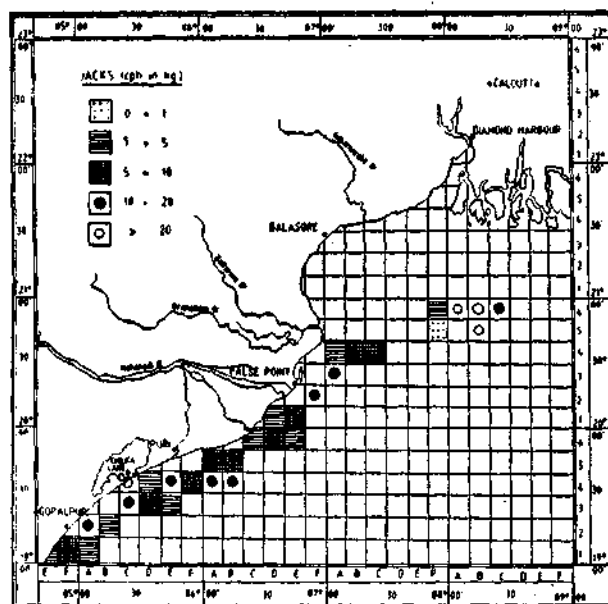

Fig. 30 : Distribution of catch rates for jacks in the explored areas off Orissa and West Bengal.

A2, B3, D2, D6, 17°-83°/B5, 18°-84°/B2, 19°-85°/A2, C3, E4, 19°-86°/A4, B4, 20°-86°/F2, 20°-87°/F2, 20°-87°/A3 and 20°-88°/C6 were 'rich' in this resource (Figs. 29 and 30). Potential yields varied from nil in 18°-05° to 3380 t in 21°-88° with the estimated total for the region at 15085 t. Presently about 5413 t of carangids are being harvested, indicating a harvestable surplus of 9672 t.

14. *Pomfrets*: *Pampus argenteus* and *Formio niger* are the main species with occasional occurrence of *P. chinensis*. 'Very rich' grounds for pomfrets were observed only in 15°-80°/E4 while the grounds in 16°-81°/C1, 20°-86°/E1

and 20°-87°/E4 were 'rich' in this resource (Figs. 31 and 32). Potential yield varied from nil in 18°-85° and 17°-84° to 465 t in 16°-82° with the estimated total for the area being at 3522 t. The annual landings along this coast are about 12370 t. Since pomfrets are columnar in habitat, bottom trawl may not be the effective gear to capture this resource. The present analysis only helps to know the relative abundance of pomfrets in different squares rather than their potential yield.

15. *Goatfishes*: *Upeneus sulphureus* and *U. vittatus* are the dominant species. Grounds were very rich for this group only in 17°-83°/C6

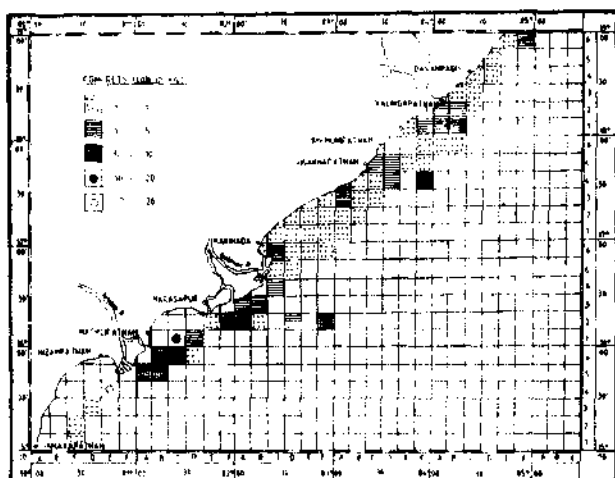

Fig. 31 : Distribution of catch rates for pomfrets in the explored areas for Andhra Pradesh.

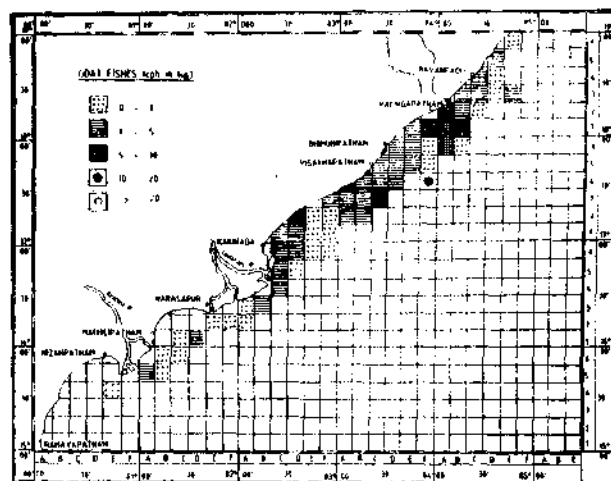

Fig. 33 : Distribution of catch rates for goatfishes in the explored areas off Andhra Pradesh.

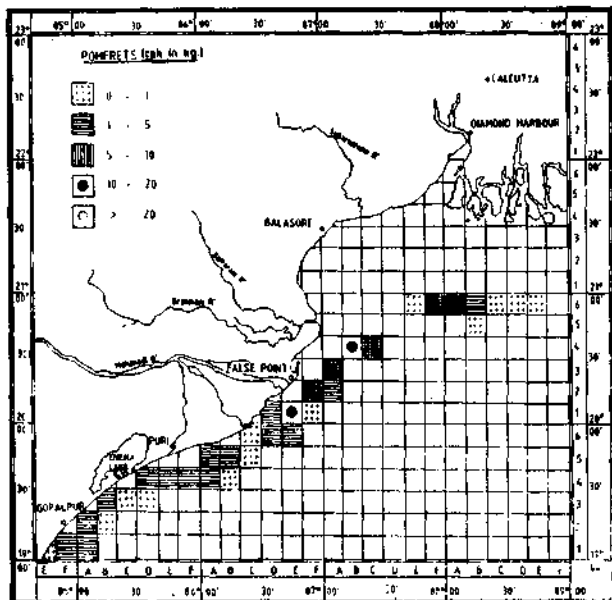

Fig. 32 : Distribution of catch rates for pomfrets in the explored areas off Orissa and West Bengal

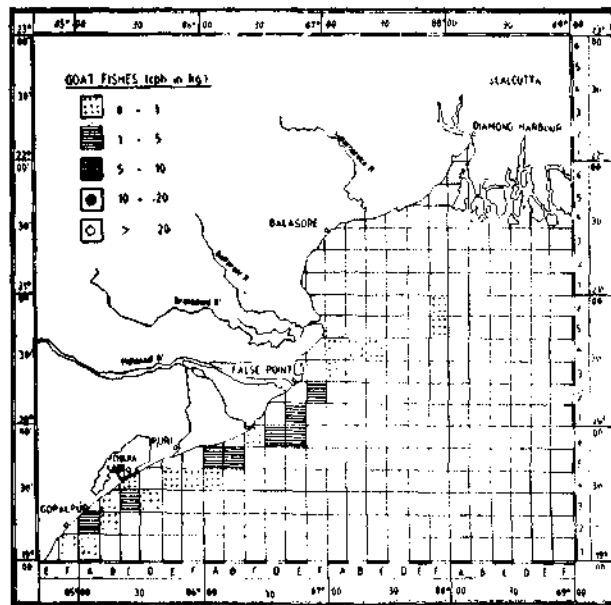

Fig. 34 : Distribution of catch rates for goatfishes in the explored areas off Orissa and West Bengal

and F4, while they were 'moderate', 'poor' or 'very poor' in most of the squares (Figs. 33 and 34). Potential yield varied from nil in 20°-88° and 21°-88° to 424 t in 17°-83° with the total for the entire region estimated as 1570 t. As the present landings of goatfishes are about 985 t the harvestable surplus is 585 t.

16. Other perches: Groups of fishes (belonging to different taxa) that do not contribute to the landings in considerable quantities individually are clubbed under this category. They are rock cods, snappers, pigface-brems, Threadfins, Seerfishes, bill fishes, barracudas, silver brems, sickle fishes, humpheads etc. 'Very rich' grounds for such miscellaneous big fishes were observed in squares 16-82/B6, 18°-84°/D5, and 20°-88°/A6, while 'rich' grounds were observed in 15°-80°/B1, E4, 16°-81°/C1, 18°-84°/E6, 19°-84°/E1, 19°-85°/D4 20°-86°/D1, E1, F2 and 20°-87°/A3 (Figs. 35 and 36). Potential yield varied from nil in 18°-85° to 850 t in 21-87 with the total for the entire region estimated as 6607 t.

17. Miscellaneous fishes: Prawns, lobsters crabs, cephalopods, clupeoids, flat fishes are the main components of this group. Potential yield of this group varied from 72 t in 18°-85° to 3508 t in 16°-82° with the total for the entire area being estimated at 26440 t. However, the estimates of potential yield of this group based on the fish trawl catches may not be valid since many of these varieties pass through the nets used by these vessels because of the big codend mesh size. Further, groups like clupeoids and cephalopods are pelagic in habitat,

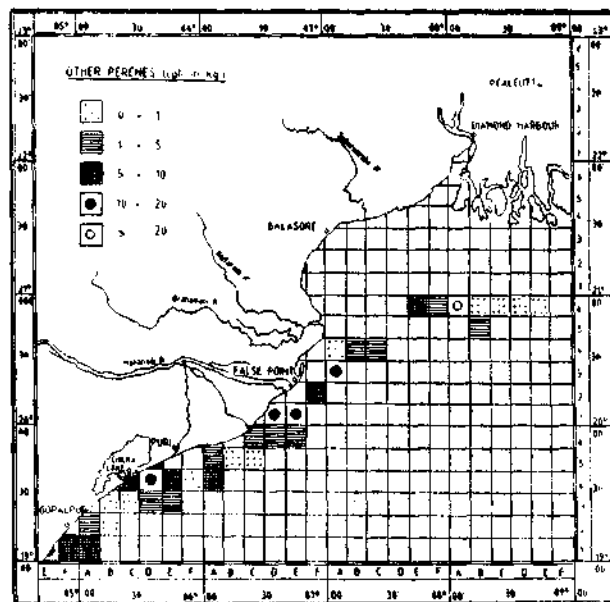

Fig 36. Distribution of catch rates for 'Other perches' in the explored areas off Orissa and West Bengal.

STATE-WISE AND DEPTHWISE DISTRIBUTION OF RESOURCES

The present account is based on bottom trawling covering 80%, 75.4% and 86.5% of the shelf area off West Bengal, Orissa and Andhra Pradesh respectively in addition to around 1200 km² off Orissa and 16,269 km² off Andhra Pradesh explored beyond the continental shelf.

In shallow waters upto 40 m of the entire region, the potential yield is 1.72 t/km² between 40 m - 180 m it is 1.94 t/km² and beyond 180 m it is 1.90 t/km². Off Andhra Pradesh the potential yield is more or less uniform in the three depth zones, whereas off Orissa it increases with increase in depth (Table 3). The high figure of 3.98 t/km² beyond the Orissa shelf could be an artifact resulting from scanty sampling.

The potential yield of demersal fishes on the continental shelf (upto 180 m) off the upper east coast is estimated at 145,502 t. Of this, the share of West Bengal is 29,312 t, Orissa-62,675 t and Andhra Pradesh-53,515 t (Table 4) Waters beyond the shelf were fairly well explored off Andhra Pradesh and to a much less extent off Orissa.

In the entire region surveyed five areas of good fishing grounds were encountered. These are; 1) 15° N-81° E, off Machilipatnam (2.60 t/km²), 2) 16° N-82° E off Kakinada (2.03 t/km²),

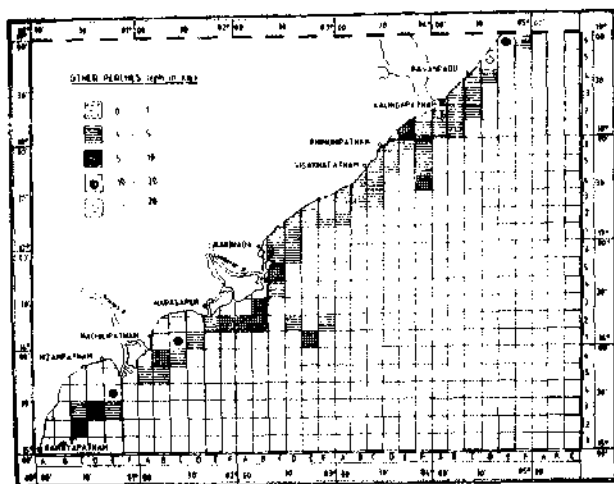

Fig. 35 : Distribution of catch rates for 'Other perches' in the explored areas off Andhra Pradesh

TABLE 3
State-wise and depth-wise distribution of potential yields of bottom trawl fishery resources in the areas explored

* State	< 40 m depth			40-180 m depth			> 180 m depth			Total area		
	Area explored (km ²)	Potential yield (t)	Potential yield/km ² (t)	Area explored (km ²)	Potential yield (t)	Potential yield/km ² (t)	Area explored (km ²)	Potential yield (t)	Potential yield, km ² (t)	Area explored (km ²)	Potential yield (t)	Potential yield/km ² (t)
Andhra Pradesh	10347	17487	1.69	15890	28753	1.81	16259	28492	1.75	42506	74733	1.76
Orissa	11438	19535	1.71	11781	27752	2.36	1200	4778	3.98	24419	52065	2.13
West Bengal	9814	17035	1.77	5146	7086	1.38	—	—	—	14759	24121	1.63
Total	31399	54057	1.72	32816	63591	1.94	17469	33270	1.90	81684	150919	1.85

* Distribution of latitude/longitude squares :

Andhra Pradesh : 15-80, 15-81, 16-81, 16-82, 17-82, 17-83, 17-84, 18-83, 18-84, 18-85.

Orissa : 19-84, 19-85, 19-82, 20-86, 20-87, 20-88, 21-86, 21-87, 21-88.

West Bengal : 21-86, 21-87, 21-88.

TABLE 4
State-wise projections of bottom trawl fishery resources upto 180 m depth

States	Area explored within 80 m (km ²)	Potential yield (t) in explored area	Total area Within 180 m depth (km ²)	Potential yield (t) extrapolated for the total area	Present demersal fish landings (t)	Remarks (Present yield vs. Potential yield)
Andhra Pradesh	26,237	46,240	30,365	53,515	57,433	Exceeds potential yield
Orissa	23,219	47,287	30,775	62,675	24,595	Far below the potential yield
West Bengal	14,759	24,121	17,935	29,312	14,113	Far below the potential yield
All states	64,215	117,648	79,075	145,502	96,141	

TABLE 5
Potential yields (t) vs present landings (t) in the three states

Group	Andhra Pradesh		Orissa		West Bengal		All three states	
	Potential yield from the area	Present demersal landings	from the explored area	Present demersal landings	Potential yield from the explored area	Present demersal landings	Potential yield from the explored area	Present demersal landings from the explored area
Sharks & skates	3531	5347	3887	1564	1854	451	9272	7362
Rays	4386	1671	1264	285	587	305	6237	2261
Catfishes	16852	3143	11378	4680	1762	4262	29992	12085
Mackerels	3351	4228	5846	824	2829	13	11828	5065
Ribbon fishes	1139	5816	217	919	154	2011	1510	8545
Silverbellies	3346	5334	1000	705	195	65	4541	6104
Threadfin breams	3431	1741	2360	607	2449	—	8240	2348
Croakers	8831	7487	5734	7676	3042	1802	17607	16985
Lizard fishes	671	995	101	250	45	—	817	1141
Drift fish	1891	500	851	—	355	—	3097	500
White fish	633	858	760	31	183	—	1476	890
Grunters	1826	—	1102	—	152	—	3060	—
Jacks	7472	4434	3822	771	3791	208	15065	5413
Pomfrets	1742	3974	11747	4134	606	4262	3522	12370
Goatfishes	1354	822	179	163	37	—	1570	985
Other perches	3041	11284	2175	1986	1391	734	6607	14004
Miscellaneous	11336	—	10215	—	4889	—	26440	—
Total Potential yield	74733	—	52065	—	24121	—	150919	—
Present demersal landings	—	77433	—	24595	—	14113	—	96141
Present pelagic landings	—	72241	—	21393	—	17412	—	111049
Total fish landings (P & D)	—	129674	—	45988	—	31525	—	207187

- 3) 18° N-84° E off Kalingapatnam (2.14 t/km²)
 4) 19° N-85° E off Chilka Lake (3.37 t/km²)
 and 5) 20° N-88° Hooghly river (2.61 t/km²)

Potential yields in relation to the present landings in respect of the 16 groups of fishes in the three states are presented in Table 5.

GENERAL REMARKS

Potential yields of bottom trawl fishery resources based on exploratory surveys are presented. Analysis of data covers a time span of 25 years (1961-1985), a geographical area of 81,684 sq. km within 15°N-21°N and 80°E-88°E upto depths of 350 m. and the operations of 5 of the 10 trawlers deployed for the survey. The potential yield for the entire area is estimated as 1,50,919 t, i. e., 1.85 t/km². In the seven latitude zones from 15° to 21°N the yield is distributed as 1.60 t, 1.93 t, 1.40 t, 1.90 t, 3.30 t, 1.40 t and 1.60 t per km² respectively. Thus the 19°N (off Orissa) emerges as very rich. The depth-wise analysis also shows that offshore waters off Orissa are rich with an yield of 3.9 t/km².

While relating the potential yield values obtained in this analysis to the present commercial landings it should be borne in mind that the commercial fishing is mostly within the 50m depth. Fishes small in size (e. g., silverbellies), low in body depth (e. g., ribbon fishes), less in girth (e. g., lizardfishes) tend to escape through the large meshes of the exploratory trawl nets, and thus not netted effectively. Sharks being active and fast swimmers can avoid capture by the trawl nets. Thus these exploratory surveys would naturally lead to the under-estimation of stocks of these groups. The survey employed fish trawl and not shrimp trawl. Hence, prawns do not figure in these surveys.

Certain groups like ribbonfishes, whitefish, jacks, (carangids), pomfrets and even mackerel which normally occur in the column or even at the surface, nonetheless, contributed to a substantial proportion of the exploratory trawl landings. These fishes are more vulnerable to and are regularly harvested by traditional gear. Potential yields of these groups based on exploratory bottom trawl surveys alone would

therefore be under-estimates. The regular and constant contribution of mackerels and jacks to the trawl landings in depths upto 180 m speak of their abundance in offshore grounds, presently beyond the reach of the traditional fishery. The present landings of the above fishes fall short of the potential yields which are in themselves under-estimates. Obviously, the actual stock are far in surplus and there is, therefore, considerable scope to expand these fisheries.

On the other hand, the present total landings too are under-estimated to the tune of at least 43,000 t, these being the fish discarded at sea by the large trawlers engaged in shrimp fishery. The fish are discarded due to shortage of cold storage space claimed by the high-value prawns.

The potential yields are more or less uniformly distributed in the three depth zones (< 40 m, 40-180 m and > 180 m) off Andhra Pradesh. Off Orissa, however, the yield increases with increasing depth. West Bengal waters are mostly shallow with average potential yields. Of the three states Orissa with its wide continental shelf holds promise for expansion of fishery in future.

The potential yields estimated in the present analysis differ considerably with those of previous workers. Mitra (1973) estimated the potential yield of the Andhra-Orissa coast upto 40 fathoms (FSI operations from Visakhapatnam Base) as 1.47 t/km² (5.1 t/square nautical mile). This is relatively a low estimate. Joseph *et al.* (1976) arrived at a standing stock of 244,432 for an area of 56,635 km² i. e., 4.32 t/km² (Table XI and XII of Joseph *et al.*, 1976). Although these authors have given potential yields also, their standing stock figures may be taken as potential yields as they did not consider the escapement factor of 0.5 as rightly pointed out by Antony Raja (1980). Krishnamoorthi (1976) also estimated potential yields for individual years for the 10 year period 1961-70 and arrived at a cumulative potential yield of 251,209.45 t for all the 10 years. He too did not consider the escapement factor (0.5). Antony Raja (1980) failed to notice that Krishnamoorthi's cumulative potential yield

value was for all the ten years and reckoned it as the potential yield.

Hence, Joseph *et al.* (1970) alone could be considered for comparison with the present analysis. Their high value of 4.32 t/km², as compared to the present value of 1.85t/km² is due to the facts that;

- 1) the area covered by Joseph *et al.*, being upto 40 fathoms, is more fertile and less in extent as compared to the area upto 180 m of the present study,
- 2) they have considered 17.5 m trawlers and *M. T. Ashok* as the standard whereas in the present study, the effort has been standardized in respect of all the five vessels considered,
- 3) Joseph *et al.* (1970) reckoned the trawling speed as 2 knots instead of 2 to 3 knots as mentioned in the log sheets of *M. T. Ashok*.
- 4) They had assumed that *M. T. Ashok* operated a 24 m otter trawl whereas the net actually used in the vessel was a 15 m otter trawl (Vide log sheets of *M. T. Ashok*).
- 5) they have not considered the escape-ment factor of 0.5, and 6) for calculating the swept area they have taken the entire length of the head rope, whereas only 50% of the head rope length is generally taken to be area effectively swept for stock assessment purpose.

Sivaprakasam (1987) in his assessment of demersal fishery resources of Indian waters, points out that along Andhra and Orissa coasts mackerel abound in the 70-200 m depths. He has given the distribution of the dominant groups of fishes in the different depth zones upto 500 m. The present analysis broadly confirms his findings particularly respecting the abundance of mackerel and columnar fishes in the offshore waters.

Finally, the present analysis brings out the following salient points: 1) presently non-demersal groups like mackerel and jacks, that contribute to the bottom trawl fisheries, also are exploited by the traditional sector much below

their potential and a good scope exists to harvest the surplus stocks, particularly in waters, beyond 40 m depth; 2) the typical demersal resources, like lizardfishes and sciaenids are being exploited to the optimum level with marginal surplus leaving no scope for future expansion; and 3) in the order of richness of bottom trawl fishery resources along the north-east coast of India, Orissa ranks first followed by Andhra Pradesh and West Bengal.

ACKNOWLEDGEMENTS

The authors express their heartfelt appreciation to the Fishery Survey of India for furnishing the fishing log sheets relating to their Visakhapatnam base. They thank Dr. B. Krishnamoorthi who supervised consolidation of the data for the period 1961-1979. The late Dr. K. V. Sekharan, and the late Shri V. Ramamohana Rao, Dr. K. V. Subba Rao, Shri M. S. Muthu and Shri P. Mojumdar have contributed much in consolidating the data. While further processing the above data for the present account considerable technical assistance was received from S/Shri M. V. Somaraju, B. Narayana Rao, K. Narayana Rao, J. B. Varma, M. S. Sumithrudu and M. Prasada Rao. The authors owe a debt of gratitude to all of them. They express their sincere thanks to Dr P.S.B R. James, Director, CMFRI, for the keen interest and encouragement given for this study. They also thank Shri C Mukundan, Head of Demersal Fishery Division of CMFRI, for reviewing the manuscript

REFERENCES

- ANONYMOUS, 1980. Industrial fisheries off Visakhapatnam coast based on exploratory surveys during 1972-1978. *Mar. Fish. Infor. Serv. T & E Ser. No. 15*: 1-15.
- ANTONY RAJA, B. T. 1930. Current knowledge of fisheries resources in the shelf area of the Bay of Bengal. BOBP/WP/8: 23 pp.
- BORISOV, N.T. 1962. Report to the Government of India on experimental and exploratory fishing in the Bay of Bengal. *FAO, EPTA Report No. 1466*.

- GULLAND, J. A. 1965. Manual of methods for fish stock assessment Part I. Fish population analysis. *FAO Fish. Tech. pap.* (40) Rev. 1 : 1-68.
- JOSEPH, K.M, N RADHAKRISHNAN, ANTONY JOSEPH AND K. P. PHILIP. 1976. Results of demersal fisheries resources survey along the east coast of India 1959-74. *Govt. of India Bulletin of the exploratory project. No. 5* : 53 pp
- KRISHNAMOORTHY, B. 1973. An assessment of *Nemipterus* fishery off Andhra Orissa coasts based on exploratory fishing. *Proc. Symp. Living Resources of the Seas around India.* 495-516.
- KRISHNAMOORTHY, B. 1976 An assessment of the demersal fishery resources off the Andhra-Orissa coast based on exploratory trawling. *Indian J. Fish.* 21 (2) : 557-565.
- MITRA, G. N. 1973. Method of estimation of fish abundance in the Indian seas and steps to be taken for management of the commercial fisheries. *Proc. Symp. on living resources of the seas around India* : 145-154.
- NAUMOV, M. V. 1961. A survey of the fishery resources of the Bay of Bengal. *FAO EPTA Report No.* 1393.
- PAULY, D. 1979. Theory and management of tropical multispecies stocks ; a review with emphasis on the southeast Asia demersal fisheries. *ICLARM Stud. Rev.* 1 : 35 pp.
- PAULY, D. 1983. Some simple methods for the assessment of tropical fish stocks. *FAO, Fish. Tech. Pap No.* : 234 ; 51 pp.
- POLIAKOV, M. P. 1961. Interim report to the Government of India on experimental and exploratory trawling in the Bay of Bengal in 1960-1961. *FAO Rome* ; pp 23.
- POLIAKOV, M. P. 1962. Report to the Govt. of India on exploratory trawling in the Bay of Bengal *FAO EPTA Report No.* 1573.
- SEKHARAN, K. V, M. S. MUTHU. K. VENKATA SUBBA RAO, V. RAMAMOohana RAO P. MOJUMDER AND S. REUBEN. 1973. Exploratory trawling on the continental shelf along the North-Western part of the Bay of Bengal. *Proc. Symp. On living resources of the seas around India* : 280-337.
- SHARIFF, A. T. 1961. A survey of the off shore demersal fisheries of Andhra Orissa coasts, 1960. *In: Souvenir Fisheries of Gujarat*, PP 46-54.
- SIVAPRAKASAM, T. E. 1937. Demersal fishery resources of the Indian exclusive economic zone. *Fishing Chimes*, 3 (3) : 49-461

THE CATFISH RESOURCES OF SOUTH WEST COAST OF INDIA - PROSPECTS AND MANAGEMENT PROBLEMS

P. S. B. R. James, V. N. Bande, N. Gopinatha Menon and K. Balachandran
Central Marine Fisheries Research Institute, Cochin-31

ABSTRACT

The marine catfishes of the genus *Tachysurus* form an important resource along Kerala-Karnataka coast. Till early seventies this resource was mainly exploited by indigenous gears and to a lesser extent by trawlers. The sudden introduction of large number of purse seines brought in a boost in the production of catfishes along Karnataka coast. This increase in the production was achieved exclusively by exploiting shoals of brooders which frequent the coastal waters for spawning in the monsoon and post monsoon months. The exploitation of the brooders year after year has led to the decline in production, probably due to poor recruitment. The steady yield of catfishes along Kerala showed a decreasing trend after the massive purse seine operations in Karnataka. The possible extent and effects of this decline are discussed in detail. The yield trends of various species of catfishes by different gears at the important fishing centres in Kerala and Karnataka have been studied in the light of declining production, and destruction of brooders. This account is an attempt to establish the degree of destruction of brooders, spawners and eggs/larvae along the entire coastal stretch, especially during September-October period. An attempt has been made to suggest suitable managerial measures to overcome this situation, so that the maximum sustainable yield can be achieved without affecting the spawning population and thereby the stock.

INTRODUCTION

Marine catfishes of the genus *Tachysurus* form an important component in the demersal resources in the coastal waters upto a depth of 80-125 m along the south-west coast of India. Though there are some published accounts on the biology and general fishery of some of the important tachysurid catfishes from Indian waters based on data from some selected centres (Sekharan, 1973 a, 1973b; Majumder 1977, 1978, Rao et al, 1977, Dan, 1977, 1980, 1985, Krishnamoorthi, 1978 and Menon, 1979, 1984 a, 1984 b), a detailed investigation on the status of this resource over the years with emphasis on the management and conservation measures, recruitment, migration and potential available is still lacking. The very objective of this account is to fill the above lacunae in our knowledge on this resource. Anon (1917) covers various aspects on the biology and fishery of important catfishes from different centres with an assessment of the stocks in the present fishing regions. The mass destruction of eggs/embryos of *Tachysurus tenuispinis* and *T. dussumieri* along the Mangalore region has been reported earlier and accordingly the Karnataka State

was advised to initiate restrictive measures to save this resource from a calamitous decline. However, the destruction still continues and another species, *T. serratus* has also been affected. Though catfishes are considered as a ground fish resource, at least in some phases of their life history, they ascend the column and surface waters for purposes of feeding and breeding. In general, catfishes prefer muddy grounds, and the young ones mostly remain at the bottom feeding on the epi- and in-fauna of such grounds. As the fish grows larger and older, they ascend the column and move towards deeper waters. All available information and observations show that after attaining maturation they congregate in large schools for breeding in shallow coastal waters and remain there till the fully developed young ones are liberated. This habit of migration of schools of gestating males/spawners makes them an easy target for many of the gears operated in the coastal belt. Such an exploitation caused damage to eggs/embryos in a small scale, when the same was exploited by more effective and mechanised gears, the devastation is manifold amounting to high mortality of eggs/embryos. The destruction is all the more pronounced when the entire school

of gestating males with eggs/embryos/larvae in their mouth are encircled by large purse-seine nets. Such a situation may lead to severe set backs in recruitment. As catfishes have longer life span, grow to larger sizes and the age at first spawning is between 2 to 4 years in most of the commercially important species, the impact of such destruction on recruitment will not be felt immediately. However, a continuous destruction of eggs/embryos/larvae by very high purse seine effort inputs will only add to the cumulative effect on the mass destruction with severe set backs in recruitment in the coming years. Since catfishes are migratory in habit, the destruction of eggs/embryos/larvae at any one centre will have its impact at other places too. Though the destruction mainly takes place along Mangalore region only, caution will have to be exercised to manage this resource after a thorough and critical study of the total estimate eggs/embryos/larval destruction year after year.

Though nothing concrete can be said about the migration pattern along the South-North direction and vice versa based on the available data, the coastward migration for breeding purpose is proved beyond doubt. An attempt has been made to interpret the South-North migration based on seasonal catch rate records from various centres along Goa to Cochin. However, only a detailed investigation by mass tagging of various species, especially shoaling ones, alone can give a clear picture of the migratory pattern of this resource. This paper examines all available data, information and observations to suggest suitable management policies by reducing the rate of removal of eggs/embryos/larvae and also to recommend methods and new avenues to explore this resource to achieve the maximum sustainable yield. The fishery managers have to bear in mind the changed conditions during the past few years and the heavy fishing pressure on the coastal environment, before formulating policies to augment production and conservation of the resource by restrictive methods. However, the ultimate management programmes should be associated with maintenance of the resource.

DATA BASE

The primary data and information were collected from important landing centres such

as Cochin, Calicut, Mangalore and Karwar along Kerala-Karnataka coast and Goa. Regular gear-wise, species-wise catch, effort, size and age frequencies in the commercial fishery and other biological parameters were collected from the above centres during the period 1979-85. Past data from Fishery Resources Assessment Division as well as from various published works on the subject were also utilised for the interpretation and recommendations suggested in this paper.

ANNUAL AND SEASONAL YIELD TRENDS

Annual catfish yield along west coast alone forms 70% of the total catfish catch of the country and the contribution by south-west coast is 54% in the catch of the west coast. During the 15 year period from 1971-1985, the catch along the south-west coast varied from 8420 tonnes in 1983 to 37192 t in 1975 with the percentage contribution of 23 and 77.6 respectively in the total west coast catch having an annual mean of 20209 t. This period showed fluctuations in the yield with high crests during 1974-75, 1979-80 and 1983 and with troughs in between (Fig.1). There was a general decline in landings in the successive years which reached its culmination in 1985 inspite of high effort inputs, both in non-mechaised and mechanised sectors.

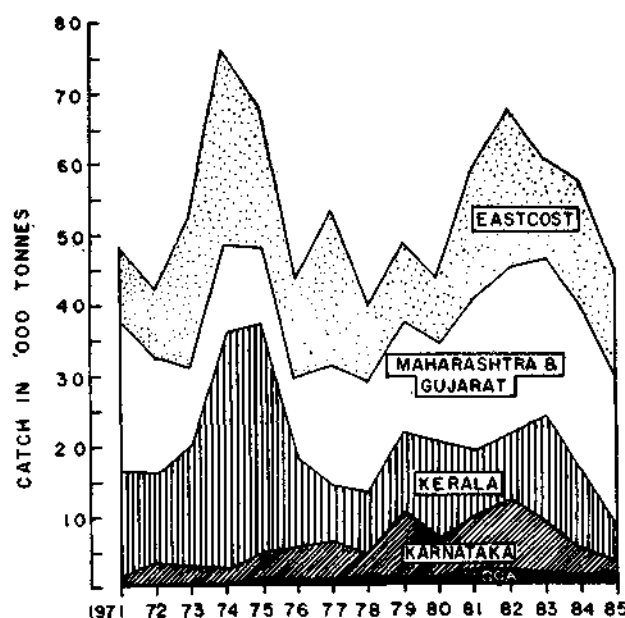

Fig. 1. Annual catfish catch trend along the maritime States of India during 1971-1985.

Kerala ranked first in the catfish catch among the maritime states of India with peak catches during 1974-75; 1979-80 and 1983, having a perfect correlation with west coast landings. The catch gradually declined and in 1985 it was at its lowest, being only 5170 t. On the other hand Karnataka, though lagging far behind till 1978, showed a boost in production after the introduction of purse seiners. But this situation continued only for a short period from 1979 to 83 and now here too the fishery is showing a declining trend with catch as low as 1572 t in 1985, a condition similar to early seventies. A review of the catch data for the past 15 years indicates that the landings in Goa do not seem to have been affected and have registered a steady but slow progress with only minimum deviation from the mean.

Annual state-wise figures show that the fluctuations, though common, have not deviated far from the mean unlike some pelagic resources. A critical study of the catch particulars of different months at the fishing centres such as Cochin, Calicut, Mangalore, Karwar and Goa emphasised the need for proper monitoring and management of this resource. At Cochin the annual yield varied from a minimum of 426 t in 1985 to a maximum of 984.9 t in 1981 with a general declining trend. May to October is the period of abundance with peak during July-September every year. Calicut centre also showed peak abundance during 1980 (190.4 t) which declined to 281 t in 1981. At Calicut the monthwise catch showed a different trend with two peaks of abundance in February, March and September-October. The catch trend seen at Mangalore is also similar to that of Cochin and Calicut with the minimum catch of 620.4 t in 1985 and the maximum of 5080 t in 1982, again showing a downward trend. As in Calicut, at Mangalore the landings have two major seasons, January-March, with peak in February and September-November.

At Karwar the highest catch was in 1932 (817t) and the lowest in 1985 (26 t), with a steady decline. The two peak periods of landings are February-April and October-November. The

catfish landing at Goa was almost steady with fluctuations from 1151 t in 1980 to 2291 t in 1981, but with a general increasing trend. Here the main fishing season is from December-May with peaks during March and December.

GEARWISE AND SPECIESWISE ABUNDANCE

On the south-west coast this resource is tapped by non-mechanised gears, such as gill nets, hooks & line, boat seines, rampani and yendi and mechanised gear, trawl. Monthwise, gearwise and specieswise catfish catch at Cochin, Calicut and Mangalore are given in Tables 1-3. At Cochin, Mangalore, Karwar and Goa in addition to trawls purse seines are also operated for catching catfish. Four species namely *Tachysurus tenuispinis*, *T. dussumieri*, *T. serratus* and *T. thalassinus* are represented in the fishery. Species abundance vary from centre to centre and gear to gear. Monthwise catch rates and gearwise CPUE at Cochin, Calicut and Mangalore are given in figs. 2-9.

TABLE 1.

Monthwise total catfish catch (tonnes) at Cochin, Calicut, and Mangalore.

Months	Cochin (1981-1985 average)	Calicut (1979-1985 average)	Mangalore (1980- 1985 average)
January	18.5	45.1	217.0
February	12.0	62.5	126.8
March	14.4	28.7	193.1
April	15.6	20.6	132.8
May	83.0	18.4	555.1
June	176.1	4.6	0.6
July	123.0	4.0	—
August	87.9	17.4	—
September	80.6	114.1	115.1
October	71.8	78.3	710.4
November	7.5	49.5	119.1
December	5.7	41.4	295.5
Annual average	696.1	484.6	2465.5

TABLE 2.

Monthwise and Gearwise catfish catch (tonnes) at Cochin, Calicut and Mangalore

Months	COCHIN			CALICUT			MANGALORE		
	Drift net (1981-1985 average)	Trawl net (1981-1985 average)	Purse seine (1981-1985 average)	Drift net (1979-1985 average)	Trawl net (1979-1985 average)	Hooks & line (1979-1985 average)	Purse seine (1979-1985 average)	Trawl net (1982-85 average)	Drift net (1979-85 average)
January	16.7	—	1.8	17.5	13.3	15.0	78.4	76.7	63.7
February	8.8	—	3.2	8.5	20.7	34.9	50.0	58.2	25.4
March	9.7	1.2	3.5	3.2	7.8	17.8	81.1	110.6	21.6
April	3.1	12.5	—	1.8	5.8	13.8	71.4	71.0	1.8
May	4.4	70.6	7.9	1.3	0.8	16.4	427.1	84.9	0.0
June	32.9	143.2	—	0.6	0.0	4.1	—	0.9	—
July	82.7	40.3	—	1.9	—	2.3	—	—	—
August	81.5	6.5	—	5.8	—	12.0	—	—	—
Sept.	71.5	6.1	2.9	28.2	—	73.4	91.9	—	32.9
October	65.3	5.1	1.5	18.2	0.0	61.0	567.7	—	79.0
November	6.4	1.1	—	10.3	0.8	39.6	44.0	99.2	33.6
December	4.6	1.1	—	12.5	1.4	28.4	317.5	59.0	51.9
Annual average	387.6	287.7	20.8	109.8	50.6	318.7	1729.1	560.7	309.9

TABLE 3.

All gear species wise monthly catfish catch (tonnes) at Cochin, Calicut and Mangalore

	Cochin - (1981 - 1985 average)				Calicut (1981 - 1984 average)				Mangalore (1982 - 1985 average)			
	<i>T. dussu- mieri</i>	<i>T. thala- ssinus</i>	<i>T. serratus</i>	<i>T. tenuis- pinis</i>	<i>T. dussu- mieri</i>	<i>T. thala- ssinus</i>	<i>T. serratus</i>	<i>T. tenuis- pinis</i>	<i>T. dussu- mieri</i>	<i>T. thala- ssinus</i>	<i>T. serratus</i>	<i>T. tenuis- pinis</i>
Jan	16.4	0.2	1.8	—	10.8	0.5	5.9	8.0	137.0	18.7	9.4	60.5
Feb	9.8	0.1	2.0	—	24.5	—	2.0	9.3	41.6	7.1	29.6	57.6
March	13.7	0.3	0.3	—	13.2	—	0.4	11.5	69.8	11.5	4.1	100.1
April	6.1	0.0	0.6	8.7	9.3	0.1	0.1	7.0	125.7	—	0.4	56.3
May	17.4	21.4	5.3	38.8	9.7	0.3	0.7	5.0	759.8	0.3	0.0	72.8
June	6.9	80.9	26.8	61.6	2.9	—	1.6	0.0	0.0	0.1	—	0.7
July	14.7	15.5	41.4	51.2	0.9	0.1	1.9	0.0	—	—	—	—
Aug.	27.3	13.0	27.0	20.5	5.6	0.9	0.8	8.1	—	—	—	—
Sept.	16.6	32.3	22.1	10.7	13.5	10.6	4.0	57.5	2.8	1.4	10.7	129.4
Oct.	12.0	32.8	25.4	1.5	8.4	18.3	1.9	43.4	100.4	4.2	26.7	222.9
Nov.	3.4	1.2	2.1	0.7	5.3	15.0	4.0	23.5	5.5	2.0	9.5	98.2
Dec.	4.2	0.0	0.4	1.0	7.0	2.5	2.5	15.4	9.4	1.6	15.9	67.2
Total	148.5	197.7	155.2	194.7	111.1	48.3	25.8	188.7	1252.0	46.9	106.4	865.7

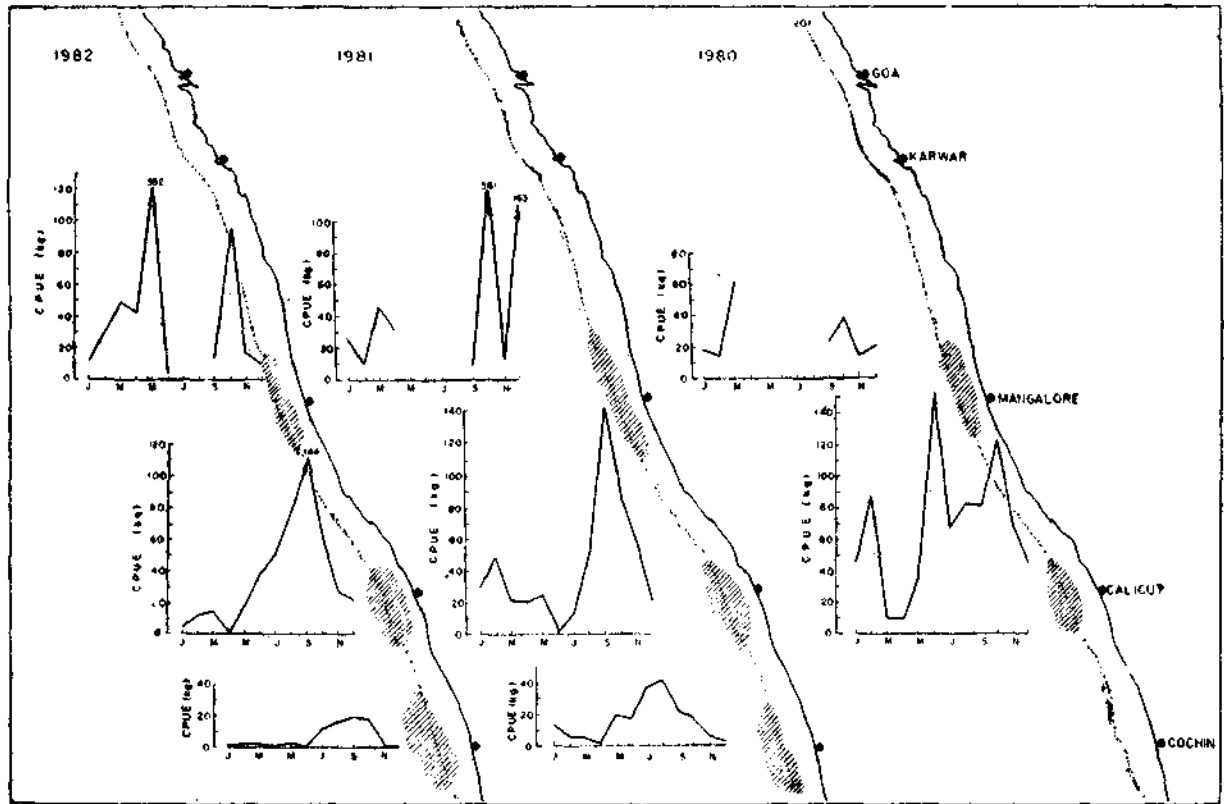

Fig. 2. Monthwise CPUE at Cochin-Calicut and Mangalore during the years 1980, 1981 and 1982 (Shaded portion denote the fishing areas)

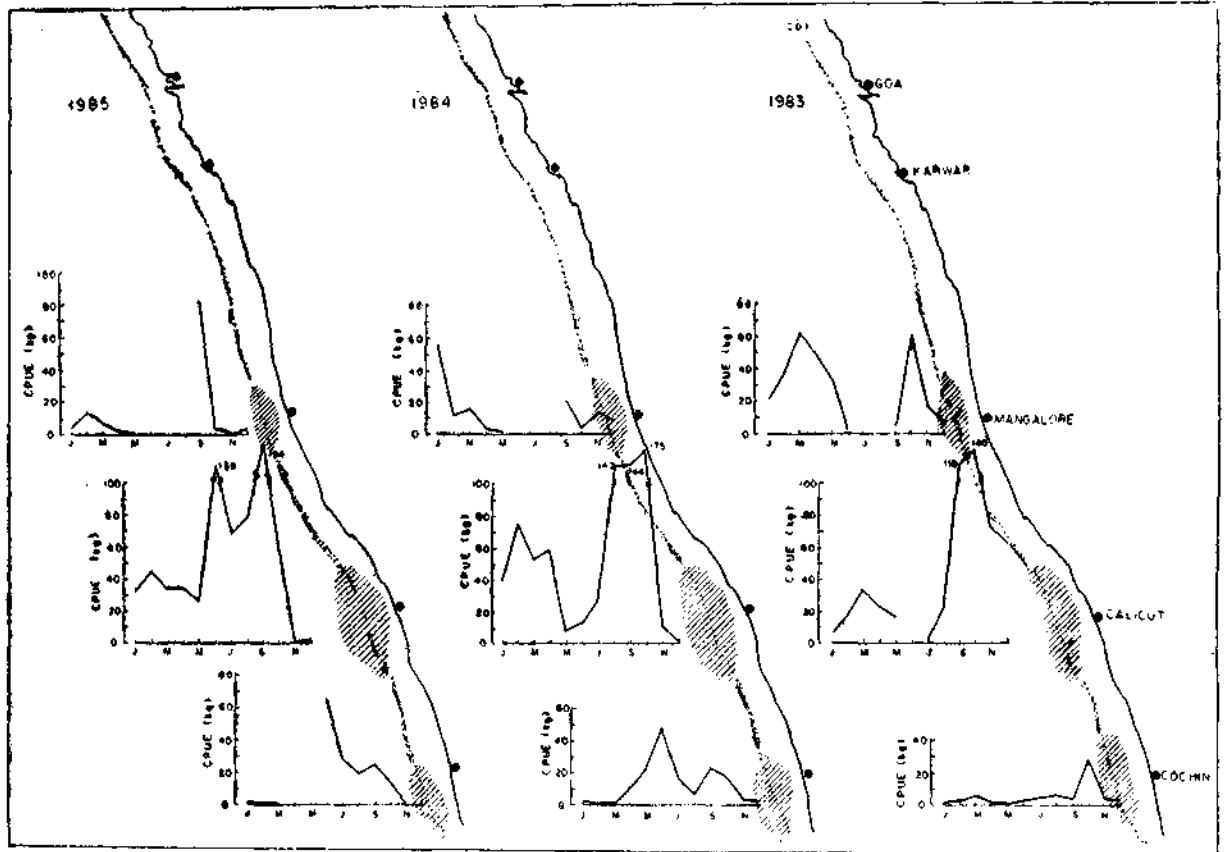

Fig. 3. Monthwise CPUE at Cochin-Calicut and Mangalore during the years 1983, 1984 and 1985. (Shaded portion denote the fishing areas)

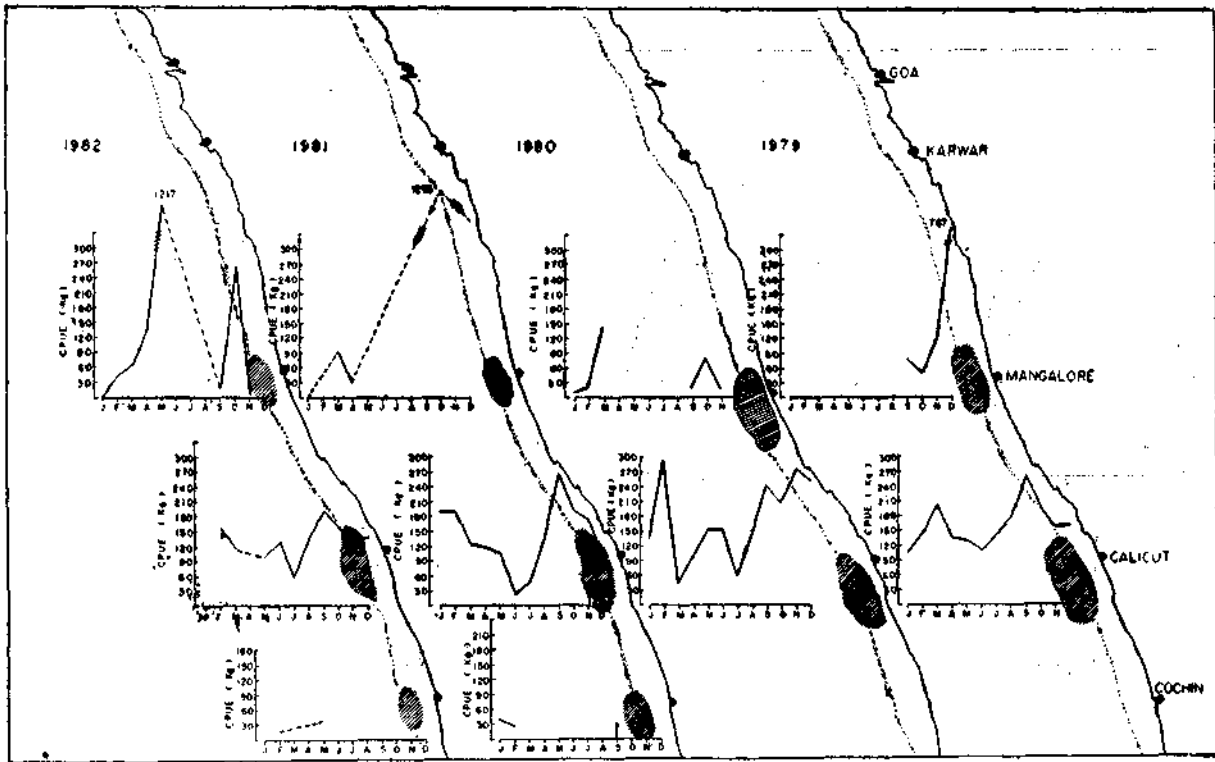

Fig. 4. Monthwise CPUE in Purse seine (Cochin and Mangalore) and Hooks & line (Calicut) during 1979, 1980, 1981 and 1982. (Shaded portion denote the fishing areas)

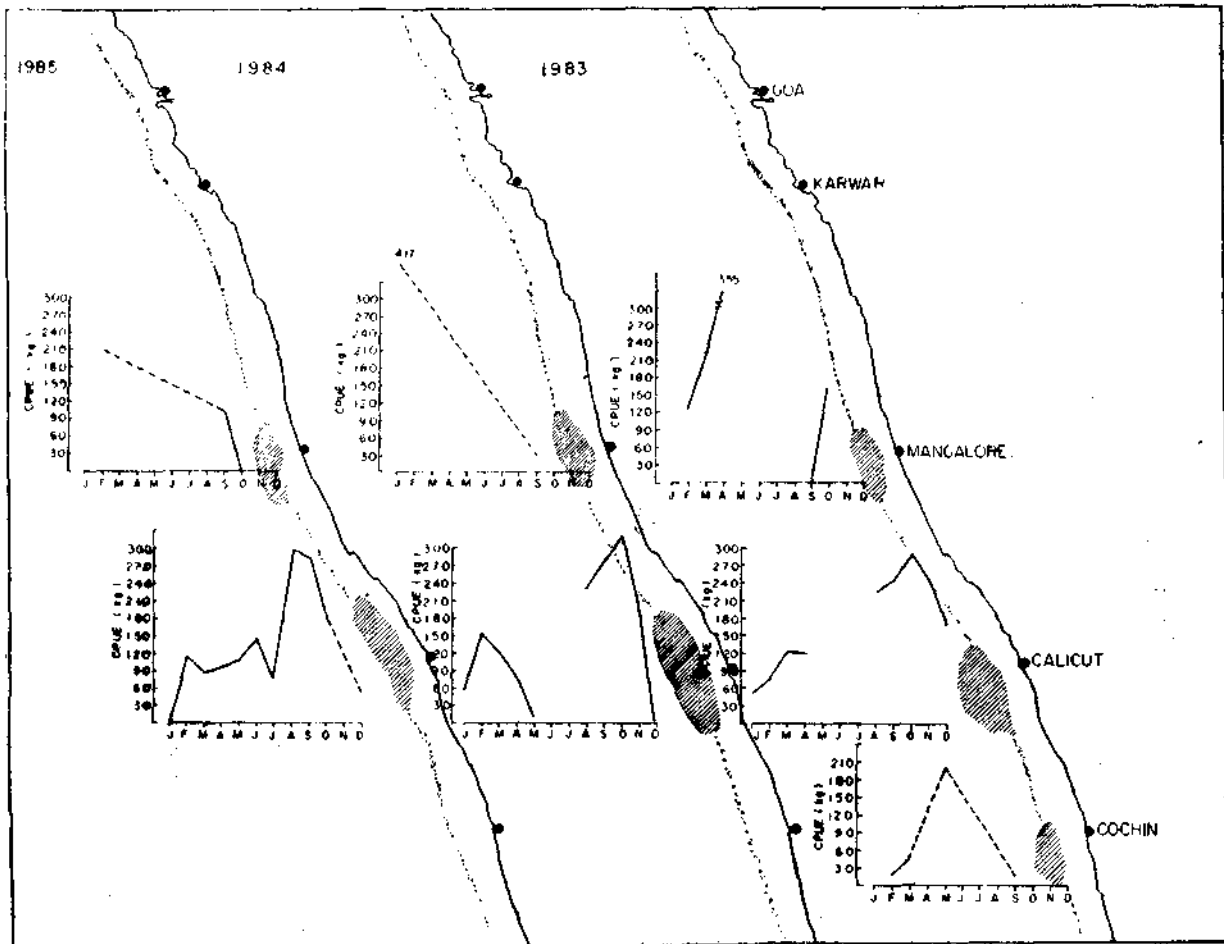

Fig. 5. Monthwise CPUE in purse seine (Cochin and Mangalore) and Hooks & line (Calicut) during 1982, 1984 and 1985. (Shaded portion denote the fishing areas).

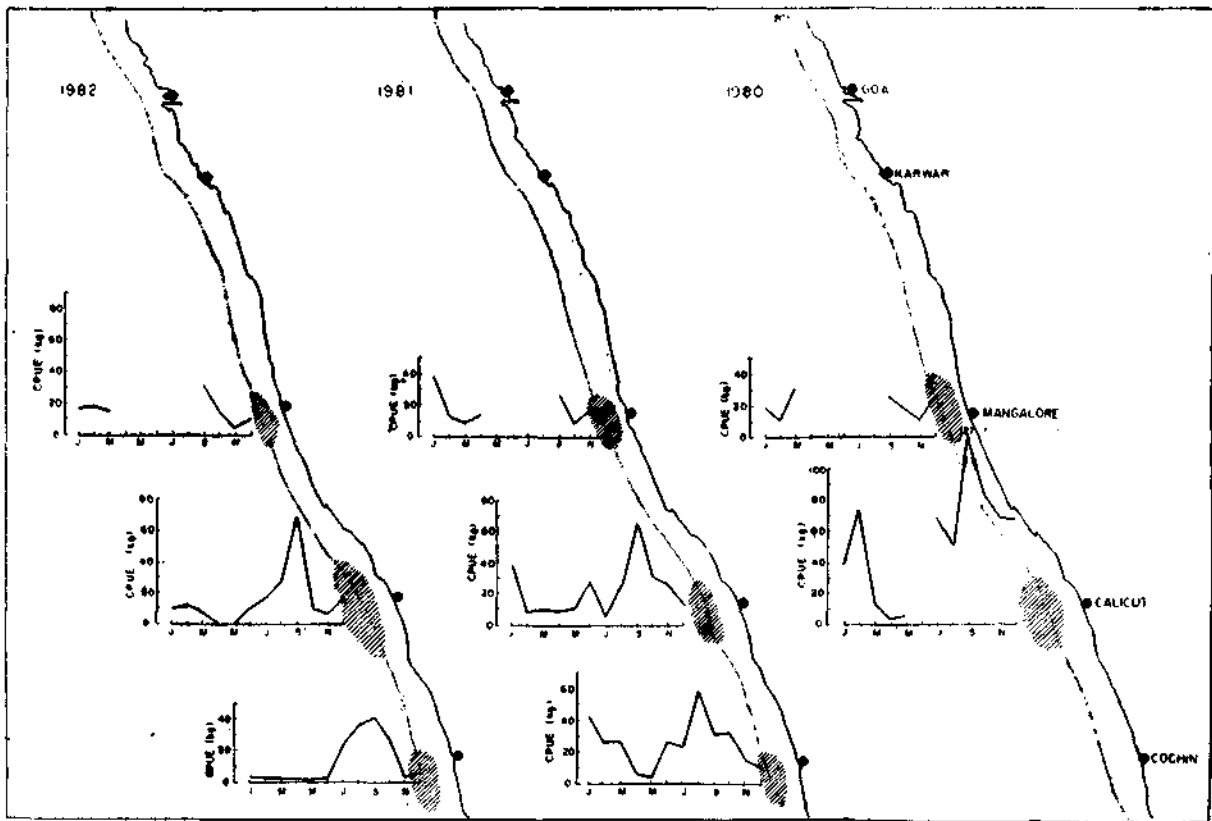

Fig. 6 Monthwise CPUE in Driftnet at Cochin, Calicut and Mangalore during 1980, 1981 and 1982. (Shaded portion denotes the fishing areas)

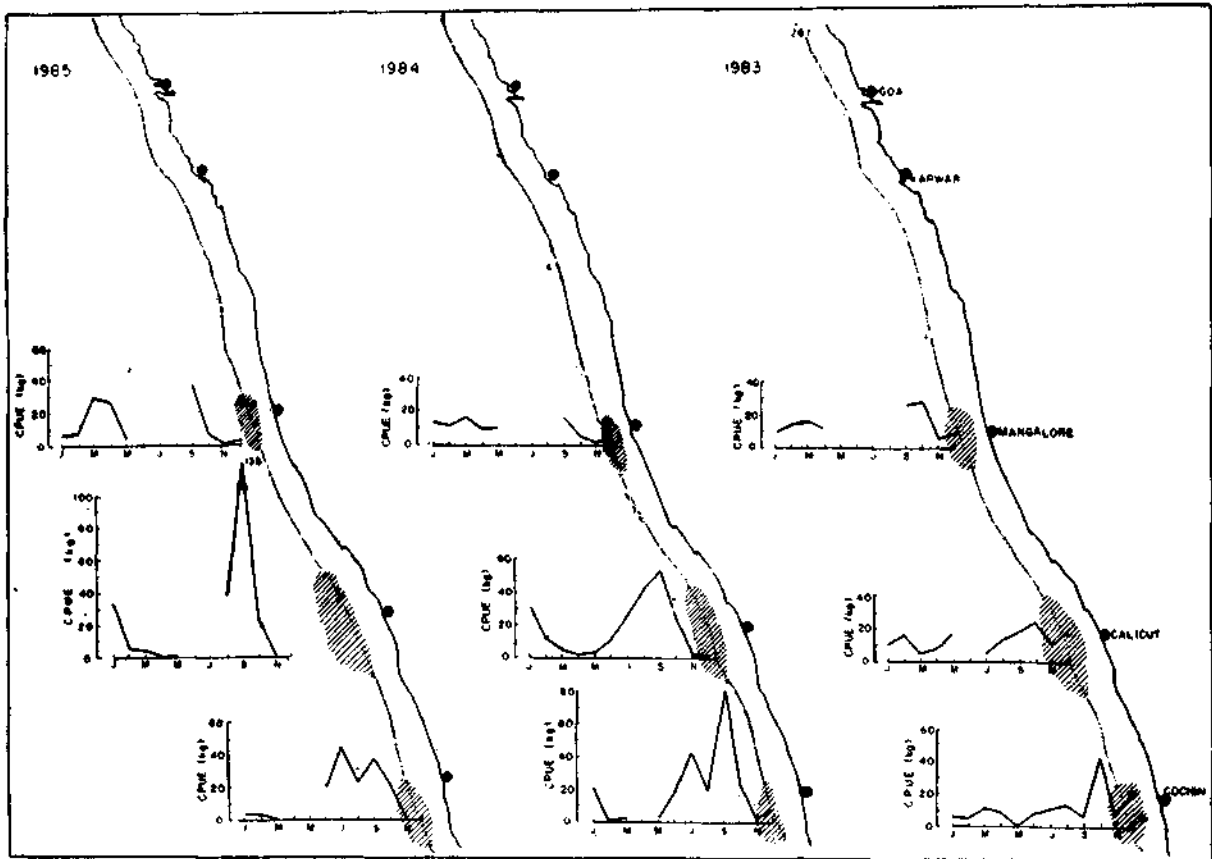

Fig. 7 Monthwise CPUE in Driftnet at Cochin, Calicut and Mangalore during 1983, 1984 and 1985. (Shaded portion denote the fishing areas)

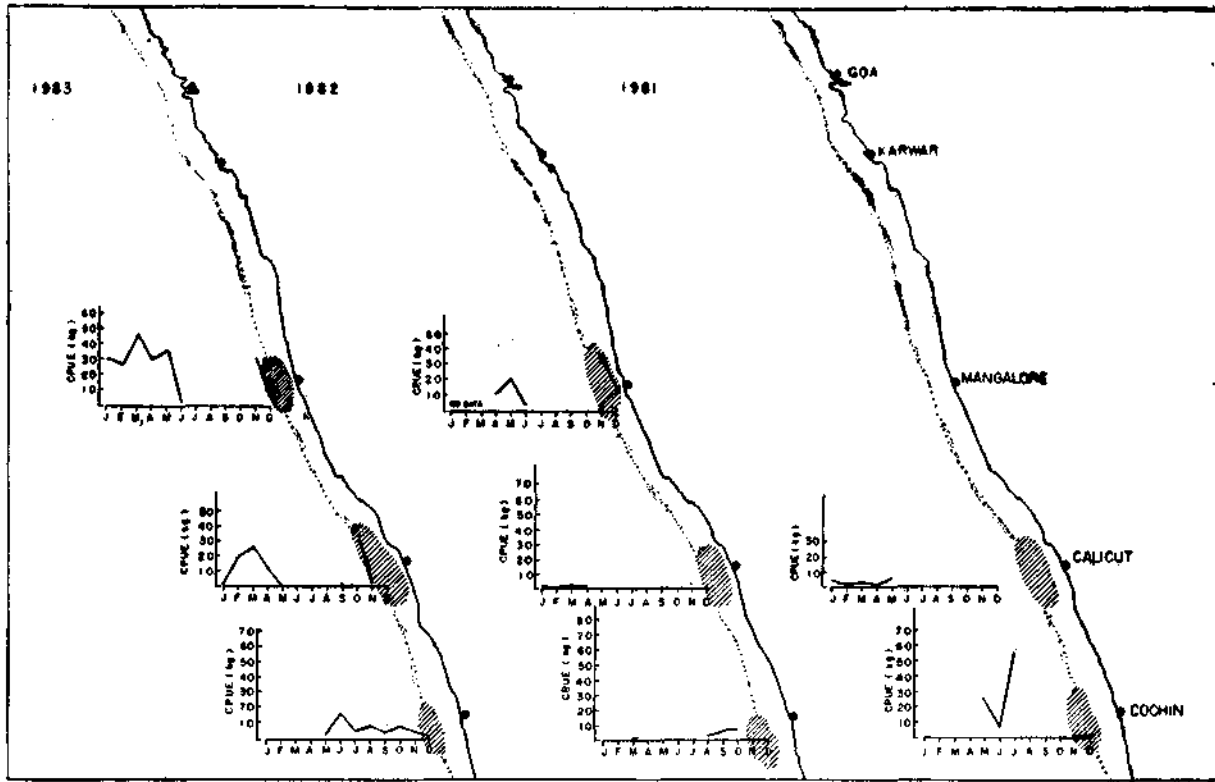

Fig. 8 Monthwise CPUE in Trawl net at Cochin, Calicut and Mangalore during 1981, 1982 and 1983. (Shaded portions denote the fishing areas)

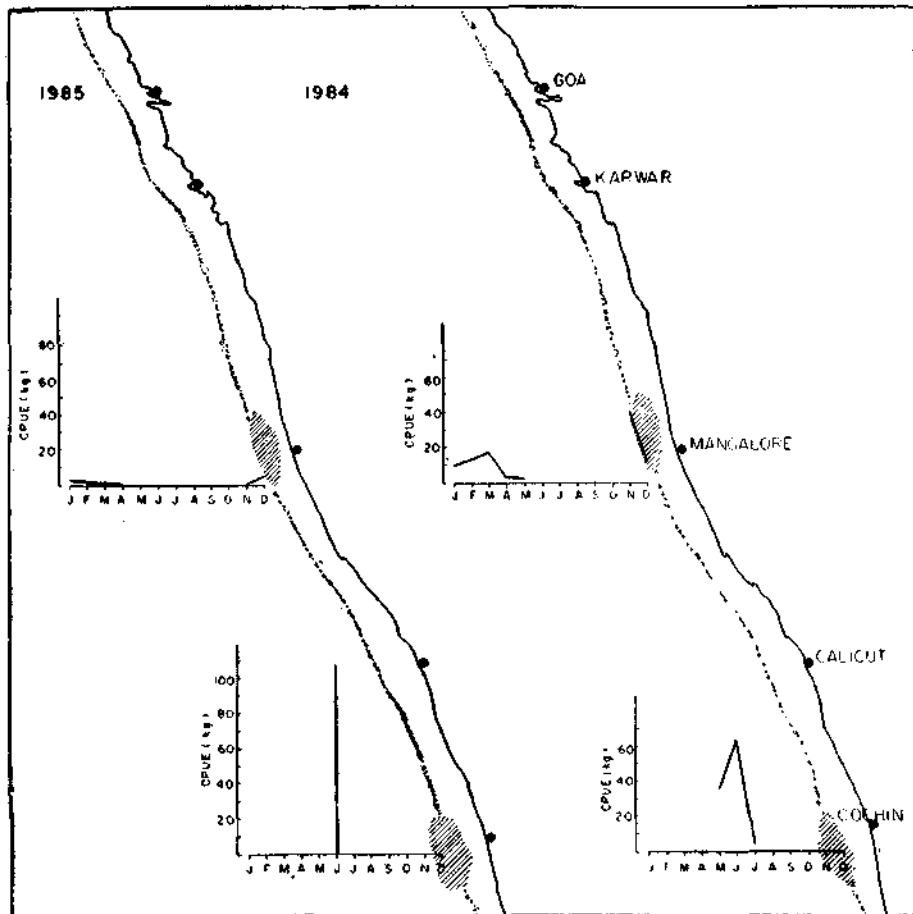

Fig. 9 Monthwise CPUE in Trawl net at Cochin, Calicut and Mangalore during 1984 and 1985 (Shaded portions denote the fishing areas)

Cochin: Purse seine operations at Cochin commenced from 1980 but the regular data are available from 1981 onwards. The annual average catch by purse seines for 1981-85 period was 20.8 t with a peak during 1983 (56t) and a sudden decline thereafter. The annual picture of species abundance shows that *T. dussumieri* is most dominant with a percentage of 65.1 followed by *T. serratus* (22.8%), *T. tenuispinis* (11.0%) and *T. thalassinus* (1.1%). In trawl gear, the annual average catch was 287.7 t with the highest catch recorded in 1984 (536.5 t). The species that rated first was *T. tenuispinis* (50.3%) with an average catch of 144.6 t. This is followed by *T. thalassinus* (43.1%), *T. dussumieri* (6.1%) and *T. serratus* (0.5%). At Cochin drift net is the most important gear for the exploitation of catfish, with an annual average catch of 387.6t and the landings fluctuating from 256.4 to 624.7 t. *T. serratus* is the important species contributing on an average 149.5 t (38.6%), next in abundance being *T. dussumieri* (30.4%). The share of *T. thalassinus* and *T. tenuispinis* is 72.4 t and 48.0 t respectively with percentages 18.7 and 12.4.

The seasonal all gear catches showed that June to September is the peak period of abundance with the highest mean value of 151.5 t in June. Purse seines landed catfish during February-May period and trawlers in June and July with high catch rates. Drift nets also showed a similar trend with peak landings during July-October period with a catch rate ranging from 28.2 kg to 32.5 kg.

In general, the seasonal catch at Cochin by all gears showed two peaks, a minor one in February-March and major in July-August, with the average specieswise landing for *T. thalassinus*-197.7 t, *T. tenuispinis*-194.7t, *T. serratus*-155.2 t and *T. dussumieri*-148.5 t. There was a gradual decline in the landings from 1981 to 1985, without perceptible wide fluctuations in the total yield. There were however, fluctuations in the landings of individual species and the reduction in the catch of one species was compensated by the hike in others, thereby maintaining the balance.

Calicut: At Calicut catfishes are exploited mainly by hooks & line, which account for

58.2 % in the 9 year's annual average catch (318.7 t). The landings, during these years, were almost steady (205.8 t in 1985 to 478.6 t in 1980) with a high hooking rate of 66.3 kg to 105.4 kg/1000 hooks. *T. tenuispinis* is the most abundant species (48.3%), the average monthly catch varying from 26 kg in June to 43.7 t in September. The peak period of occurrence of *T. tenuispinis* is September - December with an annual average catch of 160.7 t. *T. dussumieri* contributes 28.5 % in the total catfish landings and the catches vary from 162 kg in July to 12.4 t in March, with an annual average of 93.4 t and two peaks in February-April and September respectively. *T. thalassinus* is yet another important species contributing 21.3%. The catches fluctuated from as low as 34 kg in June to 18.8 t in September with an annual average of 57.9 t and peak landings are in September-November. *T. serratus* is poorly represented in the catches (1.9%) with an annual average of 8.3 t. Peak occurrence is in June-July but the landings vary from 96 kg in October to 2.3 t in June.

A downward trend was observed in the catfish landings by drift nets, with the highest value of 217.4 t in 1980 to as low as 47.7 t in 1983. With an annual average of 109.8 t, commensurate with the increase in the landings, the fishing efforts too increased till 1982 but decreased in the subsequent years with the diminishing returns. *T. dussumieri* is the dominant species with monthly average catch varying from 0.3 t in June to 135 t in January and with two peak periods in January- February and September-October. Wide fluctuations have been observed within the catch per unit effort (CPUE) from 7 kg to 35.8 kg with mean value of 16.9 kg.

T. serratus is next in importance in the drift net catches, the catch rate varying from 0.1kg in April to 9.6 kg in October. The catches are steady during July - December period. *T. tenuispinis* is yet another important constituent in the landings by drift nets, with fairly high catch rates in September-October period. *T. thalassinus*, though not so important is also recorded during August-October.

The trawl fishery for catfish existed only till 1983. Its contribution in the total catfish

landings is 14.2% during the period 1977-83 with an average annual catch of 50.6. Maximum catch is recorded (163.4 t) in 1977 and the lowest (5.8 t) in 1982. The trawl landings are exclusively comprised of *T. tenuispinis* (CPUE 40 kg) with stray occurrence of *T. dussumieri*. January-April is the peak period of abundance.

The general seasonal trend noticed at Calicut for catfish fishery, has two peaks, first one in February-March and the subsequent one in September-October. Species like *T. tenuispinis* and *T. dussumieri* are dominant in the catfish catch.

Mangalore: Purse seines at Mangalore account for 72.5% of the all gear catfish catch from the coastal waters upto the depth of 40m. The purse seines were first introduced at Mangalore in 1979 and their number multiplied at a rapid rate till 1982. This also coincided with high returns. From 1983 onwards the purse seine catches gradually declined, resulting in the stabilisation of the effort inputs. Presently over 400 purse seine units are in operation in Mangalore region. The annual average yield is estimated to be 1729.1 t with the highest catch of 4286 t in 1982, which declined to 410 t in 1985. In 1986 there was a sharp increase in the landings to the tune of 3605 t. *T. dussumieri* was the most dominant species in the catches followed by *T. tenuispinis*. Though *T. thalassinus* and *T. serratus* are not represented in the catches in the early days of purse seine fishery at Mangalore, they are caught in fairly good quantity in 1985 and '86 along with other two species. Seasonal estimates show that January-February and May and September-October are the peak periods for the purse seine fishery. Good landings of *T. dussumieri* have been recorded in January-February and May, whereas, September-October catches are exclusively of *T. tenuispinis*. *T. serratus* has two peak periods in February and October but *T. thalassinus* occurs only in September-October months.

The trawl gear contributes 17.3% in all gears catfish catch with an annual average of 560.7 t. The highest landings are

recorded (1194 t) in 1983. The dominant species contributing to the trawl catches are *T. tenuispinis*, *T. thalassinus* and *T. dussumieri* in the order of abundance. The gear is operated from November to May with *T. tenuispinis* representing the dominant species with two peaks in March (82.9 t) and November (74.7 t).

Drift gill net's share in the all gear catfish catch is 10.2%. There was a steady decline in the landings from 1981. *T. serratus* is the dominant species (39%) in this gear; next in abundance is *T. dussumieri* (31.9%) followed by *T. tenuispinis* (23.8%) and *T. thalassinus* (5.3%). Drift gill net fishery at Mangalore has two peaks, February and September-October. *T. serratus* is abundant in January and October and *T. dussumieri* in February and October.

The seasonal landing trends at Mangalore very clearly shows peak periods of occurrence in February and September - October. Species *T. dussumieri* and *T. tenuispinis* dominate the catches at Mangalore.

Karwar: At Karwar the catfish fishery was mainly supported by non-mechanised gears, like rampan, yendi and hooks and line, and mechanised trawlers till early 1978. From 1979 onwards the bulk of the landings were brought by purse seines with a steady catch till 1982 and thereafter the fishery declined. The catfish fishery at Karwar has two peak seasons in February-March and October-November and is dominated by species such as *T. tenuispinis* and *T. dussumieri*. From 1984 onwards shoals of *T. serratus* began to appear in the purse seine catches. In the early part of 1986 large quantities of just liberated juveniles of *T. serratus* were recorded in the trawl and yendi catches.

Goa: Catfishes are generally caught in Goa by rampans, yendi, trawlers and from late 1978 onwards by purse seines too. The period of occurrence is from December to May with peak abundance in December - March. Data on species-wise catfish catch from Goa region is not available for drawing conclusions on species-wise abundance.

EXPLOITATION OF BROODERS AND SPAWNERS

Ever since the introduction of purse seines in Goa, Karnataka and Kerala, there have been

* The data provided by Shri C. Muthiah, M.R.C. of CMFRI, Mangalore is greatly acknowledged.

reports of large scale destruction of gestating males and to a smaller extent, female spawners of catfishes. The exploitation of brooders existed even before the introduction of purse seine by non-mechanised gears like boat seines (Pattankolli vala), shore seines (rampan & yendi) and drift gill nets. But the quantum of destruction of eggs/embryos/larvae in the process of harvest of brooders by these less effective non-mechanised gears was either only partial or negligible. Such a destruction is inevitable due to the fact that the brooders congregate in shallow coastal belt (Figs. 10 and 11) and are vulnerable to even indigenous gears. However, this problem has altogether taken a serious turn with the introduction of purse seines, which can encircle the entire school of brooders, resulting in the removal of large quantities of eggs/embryos/larvae from the nursery grounds every breeding season, the season varying from species to species. The purse seine when initially introduced was received by the fishermen with jubilation on account of the high rate of return. It is also true that this gear accounted for a significant spurt in the catch of pelagic shoaling fishes like oil sardine and mackerel. But unusually heavy catch of oil sardine in ripe

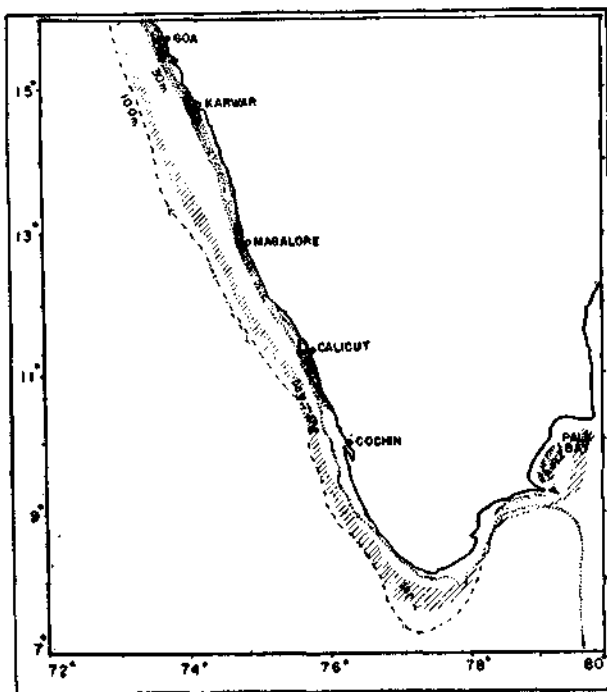

Fig. 10. Breeding grounds of *Tachysurus dussumieri* along Calicut-Goa region (stippled portion) during December-March and Matched portion portion indicate their abundance during July-August.

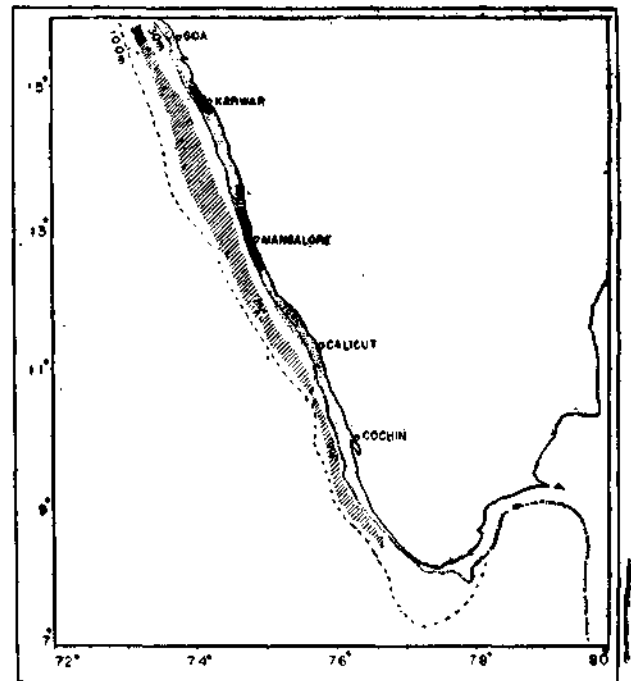

Fig. 11. Breeding grounds of *Tachysurus tenuispinis* along Calicut-Goa region (stippled portion) during September-November and Matched portion indicate their abundance in June-July

running condition during the early part of June points to the need for imposing restrictions, in the interest of conservation of the resource. The Government of Karnataka based on a timely warning from Central Marine Fisheries Research Institute, had requested the purse seine owners and other fishermen to refrain from catching spawning oil sardine and mackerel especially during May to August period.

The year 1980 witnessed another catastrophic event; the large scale landing of gestating males of catfish *Tachysurus tenuispinis* from a depth range of 25-35m, to the tune of about 528 t with an estimated 37.6 t of eggs/embryos in their buccal cavity. All this happened in a period of two months from the end of September to October from the Mangalore-Gangoli region along the South Karnataka coast (Silas *et al.*, 1980).

It is well known that large scale destruction of spawners of any species will have a deleterious effect on the recruitment and therefore on the future fishery of that resource. It is all the more evident in catfishes, whose fecundity is very low with a single spawning in the year.

Fishing of a school of gestating males accounts for 100% egg/larval mortality. More concerted action is therefore, required to conserve this resource, than any other shoaling fish, where the fecundity is very high with a high egg/larval natural mortality. This fishery is not only destructive biologically but also economically wasteful, because the eggs/embryos landed have to be discarded owing to lack of demand. Moreover, the gestating males are practically reduced in weight with a very low flesh-bone ratio due to their starvation for about two months during the gestation period.

Species-wise catfish catch by purse seines along the Mangalore coast shows that the landings of *Tachysutus dussumieri* are at its peak in December-March period and of *T. tenuispinis* during September-November, which coincided with the peak period of breeding. On an average as high as 16% of the total purse seine catch of October is composed of *T. tenuispinis* and 12% and 6.9% in December and March respectively of *T. dussumieri*. The average *T. dussumieri* catch during the four month period of December-March is 1228.7 t forming 7.4% in the total purse seine catch of the same period. The three months average *T. tenuispinis* catch (September-November) is 1199 t which comes to 6.8% in the total purse seine catch of the respective period.

The estimated average landings of gestating males of *T. dussumieri* during December-March months from Mangalore region, is 163.4 t which forms 13.3% in the total purse seine catch of this species for the corresponding period. Taking into account the mean fecundity of *T. dussumieri* as 140 ova (ranging from 108-16 ova) and the average weight of a ripe ova as 2.6 grams (2.1-3.2 grams) the average annual destruction of eggs/embryos by purse seine along Mangalore region is estimated to be 7.6 million eggs weighing 19.8 t.

The average landing of gestating males of *T. tenuispinis* during the 3 months period of September-November from the same region is estimated to be 500.6 t which forms 42% in the total *T. tenuispinis* catch by purse seine in the respective months. An estimation of the average destruction of eggs/embryos of *T. tenuispinis* in the 3 months period shows that 62 million eggs

weighing 75 t are destroyed every year from the Mangalore region, taking into account the average fecundity of the species as 50 ova (ranging from 29-89 ova) with a mean egg weight of 1.2 grams (1-1.23 grams). Almost a similar trend in the catch of gestating males as well as egg/embryo destruction has been reported from Malpe during the period September 1986 onwards. Similar reports on the destruction of brooders of *T. tenuispinis* have been reported from North Karnataka region (Karwar) by purse seine fleet during September 1982. The eggs landed on two days, 23rd and 29th September 1982 amounted to 3.9 t. The gestating males are caught from the region of 45-50 km north and south of Karwar in the depth range of 20-30m. It is also estimated that 4.3 million eggs of *T. tenuispinis* are destroyed in this process (Dhulkhed *et al.*, 1982).

There were further reports on the large scale netting of schools of *T. dussumieri* from shallow depths ranging from 10-20 m by purse seine off Mangalore-Hajmady region (Muthiah and Syda Rao, 1985). The gestating males caught during February-March period had as many as 100 numbers of embryos of fully developed in the oral cavity. The embryos were at late stage of development, the yolk sac almost absorbed and the size ranging from 40-75 mm, weighing between 2-4.3 gms. The size range of gestating males of *T. dussumieri* reported was between 51-82 cm with a weight range of 1.7-5.4 kg. This observation is in conformity with the size at first maturity of this species at 62 cm (after the completion of 4 years) as reported by Vasudevappa & James 1980. Further, it is the size at which they commonly occur along the coastal waters of Calicut-Karwar region during the period.

Thus, of the two species facing the calamitous situation of destruction of gestating males with eggs/embryos/larvae year after year along Mangalore-Karwar region, *T. tenuispinis* is most dangerously affected followed by *T. dussumieri*. However, there are also reports on the destruction of brooders of *T. serratus* from 10 m depth in the Karwar region. All the above reports and observations clearly show the enormity of egg/embryo/larval destruction caused year after year and point to an urgent necessity to conserve this resource.

MIGRATION

Catfishes which are essentially demersal exhibit both vertical and horizontal migration. The observation by the erstwhile Pelagic Fishery Project, based on echo traces, shows that at day time they swim down and settle at the bottom in dense concentrations and ascend to the column and surface waters during night and disperse. The acoustic and experimental fishing surveys along the south-west coast indicated migration of catfishes in the southward direction during monsoon months (Anon 1976). All the earlier reports and present observations both along east and west coasts show that schools of catfishes from offshore frequent the very shallow muddy coastal waters for breeding. After the release of young ones they migrate back to the deeper waters in the depth ranges 80-125 m. The Indo-Polish Industrial Surveys (Anon 1987) have reported that the catfishes, normally an important component in the offshore catches, are almost negligible during September-October. This is probably because of their coastward migration for breeding during these months.

A detailed study on yield trend and catch rates from various centres along Goa downwards shows that possible direction of migration is towards south starting from north in December and continuing southwards to Palk Bay along the south-east coast. Large schools of *T. dussumieri* have been reported in Palk Bay during August-September (Menon, 1979). In general catfishes have high catch rates at Goa during December, at Karwar in January, at Mangalore in February-March, at Calicut in March and at Cochin during June-July. (Fig. 12). The reverse migration commences sometime during August-September period as demonstrated by the high catch rates at Cochin (September), Calicut (September-October), Mangalore (October-November) and further north at Karwar and Goa during November and December. This high catch rates also probably indicate the shoreward migration of the two major species, *T. dussumieri* and *T. tenuispinis* during December March and September-November periods respectively for breeding purposes.

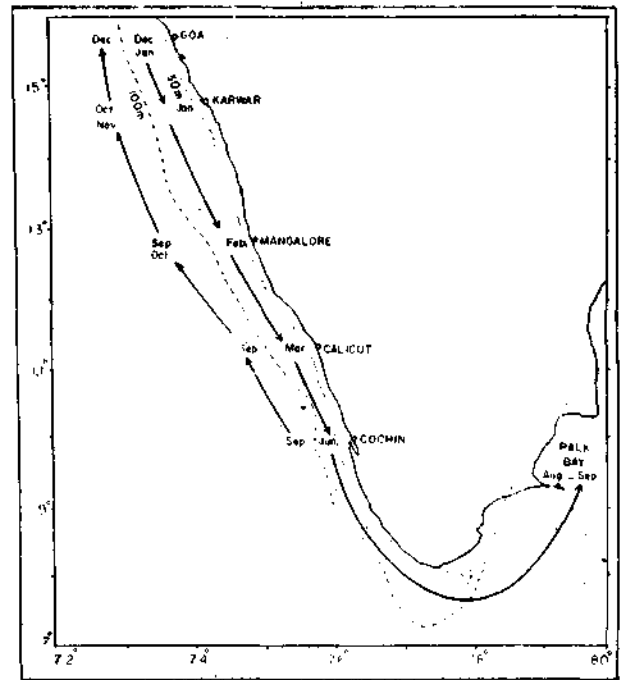

Fig 12: The probable course and period of southward and northward migrations of catfishes along south-west coast (The bold arrows indicate the direction of movements).

MANAGEMENT OF RESOURCE

Important findings

The main points which have an important bearing on the conservation, potential and exploitation of the catfish resources are given below:

1. Breeding of marine catfishes takes place in shallow coastal waters where the sea bottom is mostly muddy.
2. After breeding, sexes get segregated and male brooders move in dense schools in the shallow coastal nursery grounds.
3. Large schools of less mobile brooders are harvested en masse by purse seines along Karnataka coast leading to mass destruction of egg/embryos/larvae.
4. The coastal catfish fishery has been mainly exploited at two stages, juveniles/subadults and spawners/brooders.
5. Bottom sweeping by small trawlers along the shallow nursery grounds during post spawning months catch large quantities of juveniles.

6. An assessment of stocks of different species of commercially important catfishes from various centres indicated that all species except *Osteogeneiosus militaris* are now under heavy fishing pressure with a high rate of exploitation from the present fishing area.
7. Marine catfishes are an important component in the demersal resources in the coastal waters upto a depth of 125 m with maximum concentration in the mid-shelf region from 50-80 m.
8. They exhibit both vertical and horizontal migrations.
9. Catfishes exhibit diurnal vertical migrations; during day time they settle to the bottom in dense concentration and ascend to column and surface and disperse at night.
10. Larger members of the species are abundant in deeper water except during the breeding months.
11. Acoustic-cum-experimental fishing surveys indicate that the potential resource is rich along the mid-shelf of the south-west coast of India.
12. The need to expand and improve the use of long-line at all depths, irrespective of season is emphasised.
13. A shift in the predominance of one species to another has been noticed at some centres in the past few years.
14. Muddy bottom with rich benthic fauna is the best ground for catfish exploitation.

All the above findings suggest the need for suitable management programmes for conserving the resource on the one side and augmenting the exploitation on the other side.

Conservation

The fishing industry is aware that for a judicious exploitation and conservation of the resource, proper management programmes are necessary. But at the same time they do not want Government intervention since the implementation of conservation measures may lead to set backs in the economic returns. Since all

conservation measures are aimed to help sustained production, it is for the Government to step in and enforce some rigid conservation measures, both for biological and economic reasons. In view of the enormity of destruction of eggs/embryos of catfish which hardly fetch any price, it is necessary to restrict the purse seine operation during the peak spawning periods February and September-October along the shallow coastal belt, extending from Calicut in the South to Goa in the north up to a depth of 40 m. The justification for this restriction is to enable the brooders to complete the gestation and liberate the young ones. This will not only restrict the egg/larval mortality by fishing but will also allow the young ones to grow to larger sizes. After the completion of the incubation, the same resource can be exploited without causing any substantial reduction in total yield. In other words, the restrictive action is designed to maximise the catch with an economic objective but with a biological conservation policy.

Anon (1987) showed that most of the commercially important species of marine catfishes are at present under heavy fishing pressure, except a single species *Osteogeneiosus militaris* which has a very limited distribution along north-west coast and some parts of east coast. The only solution to overcome this situation is either to reduce the fishing pressure or to increase the size at first capture. Both are detrimental to the general policy of increasing yield and against economic objectives, at least for the first few years till a sustained state is reached. As the very objective of the industry is the maximum sustainable return in money, the tendency of the industry will be to resist any type of restrictive measures imposed by the Government. The question is how and when to implement. It should first be decided whether the short term gains should take preference over the affirmed policy of achieving a maximum sustained yield. In the process of development we have to satisfy both the above needs, but without jeopardising the resource, taking care to avoid the resource being over exploited and by preventing egg/larval mortality by fishing.

To conserve the resource, which is subjected to over exploitation, some of the common methods to reduce the fishing pressure are closed season for all or selected gears, limited operation by selected gears, mesh regulation, increase in the size at first capture and increase in the hook size etc.

A closed season for all types of gears during February and September-October period is an impracticable solution; since it will have great set backs in terms of total yield and socio-economic conditions of the fishing community. Similarly, total ban on the operation of the harmful gears like purse seine will be totally unacceptable to the fishermen, since this is the time when they get maximum returns by catching oil sardine, mackerel and other pelagic schools which frequent the coastal waters during this part of the year. Increase in the mesh size and size of the hooks to increase the size at first capture is meaningless as far as catfishes are concerned. Because of their barbed spines, even smaller catfishes may get entangled in the larger meshes of any gear. Further, being scavengers by nature, irrespective of size, they will bite the bait from any size of hook. Both the above restrictions have, therefore, only theoretical base and no practical application in case of catfishes.

In order to conserve the resource and to prevent it from over exploitation, there is an urgent need to stop the exploitation of the brooders by purse seines. Past experience shows that the catfish schools can be readily distinguished from other pelagic schools, by skilled fishermen. To generate a willingness among the fishermen to avoid such schools during the breeding season, they should be educated to make them aware of the grave and critical situation which may result in the event of the destruction of the brooders en masse. Once the fishermen realise the implications of the large scale destruction of the eggs/embryos, the restrictions imposed on the operation of purse seine can very well be suspended. However, such a 'regulated inefficiency' has to be introduced and continued till the above situation is remedied. In extreme cases of violations punitive measures, such as stringent punishment in the form of fines and penalties may have to be imposed on the errant boat

owners who land the brooders, disregarding the restrictions. Entry for selected gears, such as hooks and line, gill nets and boat seines, having less catch rate and thereby no harmful effect on the brooding stock, is a more feasible solution to minimise the egg/larval destruction.

Small scale mechanised trawlers operating in the shallow coastal waters, sweep the bottom ceaselessly day and night to harvest the highly priced prawns. In the process, during the post spawning months, huge quantities of juvenile catfishes, ranging in size from 70 to 100 mm are caught. They hardly fetch any price. There are already restrictions on the operation of small trawlers in shallow coastal waters, mainly aimed to protect the juveniles and young ones of prawns and fishes which are found there. Very often these restrictions are violated by the trawlers to exploit the rich prawn varieties which are found in the coastal region during monsoon and post monsoon months. It is, therefore, necessary to strengthen the vigilance machinery for strict enforcement of the restrictions.

Resource potential

Eventhough the narrowness of the shelf of the south west coast restricts trawling operations to a much limited extent as compared with the north-west coast, the catfish catch trend by exploratory trawlers prove that there are rich grounds for this resource. Bull trawling conducted along Cannanore-Cape Comorin belt during 1957-58 revealed that catfish forms 2.5% in the total catch in the Cannanore-Calicut, region but declines further south in Alleppy-Cape Comorin region (Tholasilingam *et al.* 1938). The erstwhile Pelagic Fishery Project survey indicated that off Kerala the catfish abundance is at its peak during April-September period, whereas the landings are high during September-December period. Similarly, April-September are the months of highest abundance along Karnataka, while the peak landings are in January-March and September-November. Peak abundance in the mid-shelf region at one period and heavy landings in another period is mainly due to the inaccessibility of this resource by traditional gears and less effective exploitation by small mechanised gears in deeper regions during the monsoon months, when the stocks

are in highest abundance. The highest estimated average biomass is along the Kerala coast, to the tune of 43800 tonnes. Further, the course of migration indicates that the bulk of the stock remains off the Kerala and Karnataka coast for a longer duration, (July-August) at a depth range of 50-80 m (Rao *et al.* 1977). These findings give tremendous scope for the exploitation of larger fishes from deeper water by suitably deploying bottom trawls during day and mid-water/pelagic trawls during night, depending on the diurnal vertical migration. For this purpose large and stable vessels equipped with suitable trawl gears are to be added to our offshore fishing fleet. In addition, long lines and gill nets can also be utilised for effectively tapping this resource.

The shoreward migration for breeding during January-March and September-November can also be effectively utilised for increasing the rate of exploitation by increasing the effort inputs of long lines, which have high hooking rates of catfishes and at the sametime leave the brooders unaffected. Further, after giving due allowance for brooders to complete the gestation period and liberate the young ones, the spent recovering shoals of males can be exploited by purse seines. Probably this can be achieved only after the breeding season is over, when they begin their offshore migration to deeper waters.

Only through planned and judicious exploitation can the stability in production be achieved without hampering the potential stock. The excessive, wasteful and destructive fishing effort expended and the resultant devastation of eggs/embryos/larvae at a few centres along Karnataka or Kerala may have far reaching effects, as the resource migrates from south to north or vice versa. In order to augment full production, the industrial fishery has to make full use of the scientific knowledge available on the biology and behaviour of catfishes coupled with their availability in space and time and vulnerability to various gears.

REFERENCES

- ANONYMOUS, 1987. Marine Catfish Resources of India: Exploitation and Prospects. *CMFRI Bulletin* 40 : 1-94.
- DAN, S. S. 1977. Maturity, spawning and fecundity in the catfish *Tachysurus tenuispinis* (Day), *J. Fish.* 24 : 96-106.
- DAN, S. S. 1980. Age and growth in the catfish *Tachysurus tenuispinis* (Day). *Indian J. Fish.* 27 (1 & 2) : 220-235.
- DHULKHED, M. H., S. HANUMANTHARAYA AND N. CHANNAPPA GOWDA 1982. Destruction of eggs of catfish, *Tachysurus tenuispinis* by purse seiners at Karwar. *Mar. Fish. Infor. Ser. T & E Ser. No. 44* : 16-17.
- KRISHNAMOORTHY, B. 1978. A note on the trends of catfishes, *Tachysurus thalassinus* and *T. tenuispinis* based on the exploratory data for the period from 1966 to 1976. *Indian J. Fish.* 25 (1 & 2): 268-270.
- MENON, N. G. 1979. Studies on the biology and fishery of the Giant Marine catfish, *Tachysurus thalassinus* (Ruppell) Ph.D. thesis to University of Cochin (unpublished).
- MENON, N. G. 1984. a Observations on the intraovarian ova of a few tachysurids from Indian waters. *Indian J. Fish.* 31 (2) : 250-256.
- MENON, N. G. 1984 b. On the biology of the flat-mouthed catfish, *Tachysurus platystomus* (Day) from Mandapam. *Indian J. Fish.* 31 (2) : 293-308.
- MOJUMDER, P. 1977. Length frequency studies in the catfish, *Tachysurus thalassinus* (Ruppell) off Waltair during the years 1964-65 to 1960-70 *Indian J. Fish.* 24 : 90-95.
- MOJUMDER, P. 1978. Maturity and spawning of the catfish, *Tachysurus thalassinus* (Ruppell) off Waltair coast. *Indian J. Fish.* 25 (1 & 2) : 109-121.
- MUTHAIAH, C. AND G. SYDA RAO 1985. Occurrence of *Tachysurus dussumieri*, (Val.) with incubating young ones off Mangalore, *Mar. Fish Inform. Ser. T & E Ser. No. 61.*, 14-15.

- RAO, K. V. N., AND J. SANKARASUBRAMANIAM 1977. Resources of ribbon fishes and catfishes off the south west coast of India. *Seafood Export J.* 9 (11) : 9-26.
- SEKHARAN, K. V. 1973 a. The depth distribution of the Catfishes *Tachysurus thalassinus* (Rupp.) and *Tachysurus tenuispinis* (Day) in the South Western Bay of Bengal. *Indian J. Fish.* 20 (1): 191-202.
- SEKHARAN, K. V. 1973 b. On the catfish resources of the coasts of Andhra Pradesh, Orissa and West Bengal. *Proc. Symp. Living Resources Seas around India, CMFR Institute*, 517-536.
- SILAS, E. G., P. PARAMESWARAN PILLAI M. H. DHULKHED, C. MUTHIAH AND G. SYDA RAO 1980. Purse seine fishery - Imperative need for regulation *Mar. Fish. Info. Ser, T & E. Ser. No.* 24 : 1-9.
- THOLASILINGAM, T., K. C. GEORGE, M. G. DAYANANDAN. P. KARUNAKARAN NAIR AND K. NANDAKUMAR. 1973. Exploratory trawl fishing and ground fish resources along the Kerala coast and adjacent seas. *Proc. Symp. Living Resources, Seas around India CMFR Institute* : 241 257.
- VASUDEVAPPA, C. AND P. S. B. R. JAMES 1980. Maturity and spawning of Marine catfish *Tachysurus dussumieri* (val). along the South Canara Coast. *Proc. Indian Natn. Sci. Acad.* B 46 (1): 90-95.

MIGRATORY WINTER BAG-NET FISHERY IN COASTAL WATERS OF THE HOOGLHY ESTUARY

B. N. Saigal, P. M. Mitra and H. C. Karmakar
Central Inland Capture Fisheries Research Institute Barrackpore, West Bengal

ABSTRACT

The migratory winter bag-net fishery is a typical feature of the coastal waters of the Hooghly estuary. 4,000 men with about 800 bag-nets migrated from different estuarine areas and established fishing camps in different islands during 1984-85 and 1985-86. Three and a half months seasonal fishery accounted for an average estimated fish yield of 17,872 t, forming about 71% of the total fish yield from the estuary as against 29% to 33% about 15 years ago. An average catch per unit of effort of 152 kg was about 18 to 36 times that obtained in the upper and middle stretches and about 3 times more than that 15 years ago in the lower coastal waters. *Harpodon nehereus*, *Trichlurus* spp., *Pama pama*, *Setipinna* spp. and different species of prawns dominated in the catches. The bulk of the catches are sundried and exported to marketing centres. The reasons for tremendous increase in the winter migratory bag-net catches have been discussed.

INTRODUCTION

The river Ganges prior to draining into the sea has given rise to an extensive estuarine system covering the southern parts of West Bengal and Bangladesh. This estuarine system support important commercial fisheries of a

number of fish and prawn species. The portion within the Indian territory in southern West Bengal comprises the Hooghly-Matlah estuarine system and has as its principal component, the main channel known as the Hooghly river which extends landwards for nearly 290 km from the confluence of the river in the Bay of Bengal.

The lower most portion of the Hooghly-Matlah system constitutes the estuarine net work formed by the main channel, its distributaries with their further sub-divisions and cross connections which flow into the sea and give rise to an extensive deltaic system in the process. The estuarine waters cutting through and adjoining this extensive deltaic region known as 'Sundarbans' support the richest fisheries in the whole estuary contributing about 90% to the total landings.

A unique feature of the Hooghly estuary is the migratory winter fishery consisting of stationary bag-nets locally known as 'Beenjals'. Large number of bag-nets fishing parties migrate from different areas of the estuary during winter to suitable spots near the sea face in the lower zone of the estuary. The fishing parties establish their camps and remain engaged in bag-net fishing operations during end of October to early February. The fishery has come to be known as migratory bag-net winter fishery. During 1984-85 and 1985-86 two major concentrations of such migratory fishing parties, one on Sagar Island at the mouth of the Hooghly estuary and the other around Fraser-gunj, Bokkhali, Kalisthan and Upper and Lower Jamboodwip complex were established. The fishing camps so established are commonly called 'Khunties'. The major importance of the migratory bagnet fishery of winter lies in its high share in the total landings from the lower zone and from the whole estuary in recent years. Investigation on winter migratory bag-net fishery except the centre Sagar Island was carried out and reported by Datta *et. al.*, 1975. But no information on this fishery is available for last one decade. The analytical information based on investigation and data collected during 1984-85 and 1985-86 winter and the important characteristics of the fishery revealed by it are embodied in this paper.

DATA BASE AND ESTIMATION PROCEDURE

An inventory of the total number of migratory fishermen, their holdings in terms of bag-nets, boats possessed by each fishing party was

undertaken prior to the commencement of winter bag-net fishery operations and this was done by visiting individual camps for eliciting information. Adopting a 4-day sampling procedure in a month based on direct observations, information pertaining to total fish catch, catch per unit of effort and species composition of the bag-net landings was recorded. The days of observation were selected following a systematic sampling plan. Total catch, effort input for the days of observation were noted for all the camps at a site. For ascertaining species composition, a few random samples from the catches from fishing camps were examined.

An estimated monthly total catch of a landing site is

$$\hat{Y} = \frac{N}{n} \sum_{j=1}^n \sum_{i=1}^n Y_{ij}$$

where Y_{ij} = total catch on j th day of the i th fishing camp

N = Number of fishing days in a month

n = Number of sampling days selected

Similarly, an estimated monthly total effort of a landing site is

$$\hat{X} = \frac{N}{n} \sum_{j=1}^n \sum_{i=1}^n X_{ij}$$

where X_{ij} = total effort on the i th day of the j th fishing camp

So, the average C. P. U. E. of a landing site is

$$\text{estimated as C. P. U. E.} = \frac{\hat{Y}}{\hat{X}}$$

The different spots where the fishing camps "Khunties" were set up on the western flank of deltaic Sunderbans facing the sea are shown in Fig. 1. The bag-net fishing parties from different areas of the southern West Bengal start migrating in the lower zone towards the end of October. Their migration is over by the end of first week of November and they start setting up fishing camps simultaneously. Each camp consists of a fair amount of enclosed area with a small hutment within the enclosure and is used as a shelter and for stocking the

RESULTS

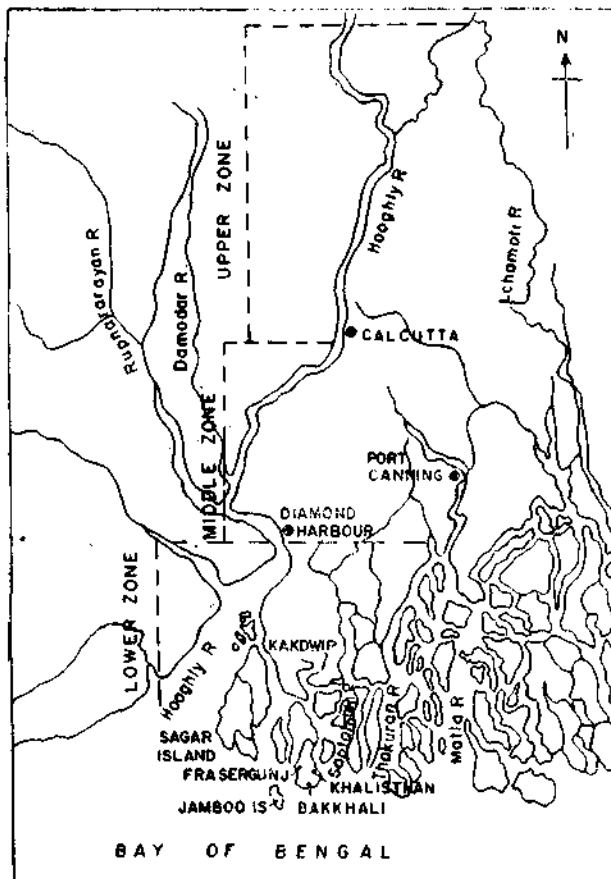

Fig. 1 Map of Hooghly estuary showing the fishing camps.

dried fish. The open space and the enclosure are utilised for drying the daily catch.

Inventory: The fishermen population migrating to various centres, the number of bag-nets possessed by them, the number of mechanised and non-mechanised boats put into operations and the number of fishing camps set up in 1984 and 1985 winter fishery operations are presented in Table 1. Each of the fishing camp at Bakkhali, Kalisthan and Jamboodwip complex had at least one mechanised boat. During earlier years deployment of mechanised boats was not resorted to for winter fishery operations. Distribution of bag-nets at different centres according to size (No. of meshes at the periphery of the mouth) is presented in Table 2. Size of a bag-net is normally indicated by the number of meshes at the periphery of the mouth. The nets are classified as medium, large and very large groups characterised by '800 to 1000', 'above 1000 to 1200' and 'above 1200' meshes at the mouth respectively. Majority of nets belonged to the large group. Except at Sagar Island nets operated at other centres belonged mainly to large and very large groups. A very few smaller nets with less than 800 meshes at the mouth were encountered at Sagar Island only.

TABLE 1

Centre-wise concentration of fishing camps, bagnets, boats, men engaged in winter migratory bagnet fishery in lower estuary during 1984-85 and 1985-86

Centre	Fishing camps		Bdgnet		Boat		Men engaged in fishing	
	1984-85	1985-86	1984-85	1986-86	1984-85	1985-86	1984-85	1985-86
Frazerganj	18	22	68	87	37(8)	46(10)	246	394
Bokkhali	19	13	110	76	59(19)	35(10)	699	367
Upper Jamboo	21	19	137	131	62(17)	61(16)	741	898
Lower Jamboo	28	18	189	142	86(26)	63(20)	1366	889
Sagar Island	83	82	243	267	103(2)	112(3)	777	812
Kalisthan	—	19	—	121	—	60(19)	—	597
Total	169	173	747	824	347(72)	377(78)	3729	3967

Figures in parenthesis indicate the number of mechanised boats

TABLE - 2

Distribution of bag net, according to size (no. of meshes at mouth) of winter migratory bag-net fishery during 1984-85 and 1985-86

Size (No. of meshes at mouth)	<800		800-1000		>1000-1200		>1200		Not available		Total	
	1984-85	85-86	1984-84	85-86	1984-85	85-86	1984-85	85-86	1984-85	85-86	1984-85	85-86
Centres												
Frazerganj	—	2	6	8	25	16	37	61	—	—	68	85
Bokkhali	—	—	—	—	39	5	71	71	—	—	110	76
Upper Jamboo	—	—	2	—	36	—	99	131	—	—	137	131
Lower Jamboo	—	—	—	—	45	—	144	142	—	—	189	142
Kalasthan	—	—	—	—	—	—	—	121	—	—	—	121
Sagar Island	10	2	150	75	51	99	29	90	3	1	243	267
Total	10	4	158	83	196	120	380	616	3	1	747	824
Percentage of total	1.34	0.48	21.15	10.08	26.24	14.56	50.87	74.76	0.40	0.1	100	100

Centre-wise comparison in respect of total fish yields and C. P. U. E.: The total estimated winter bag-net fish landings amounted to 19,639.5 and 17581.4 t with an average CPUE of 133.4 and 169.8 kg in 1984-85 and 1985-86 respectively. Cyclonic storm and flood in

early winters of 1985 resulting in 24% less effort input compared to 1984 was mainly responsible for the decrease in catch during 1985-86. Thus despite higher CPUE value in 1985-86 the total yield decreased by about 10%. The catch abundance at different centres is

TABLE-3

Centre-wise estimated catch(t) in Winter migratory bagnet fishery in lower estuary during 1984-85 and 1985-86

Centre	1984-85			Total	1985-86			Total
	Mid. Oct. & Nov. 1984	December 1984	January & early Feb. 1985		Mid. Oct. & November 1985	December 1985	January & early Feb. 1986	
Frazerganj	436.6	110.5	201.5	748.6 (3.8)	399.1	397.7	192.1	988.9 (5.6)
Bokkhali	1109.6	803.6	2137.2	4050.4 (20.6)	760.5	607.1	586.8	1933.4 (11.2)
Upper Jamboo	1679.1	1129.1	1497.2	4305.4 (21.9)	1734.4	1443.8	1589.2	4772.4 (27.1)
Lower Jamboo	3454.3	3150.3	3472.9	10077.5 (51.3)	3216.0	1151.2	1046.5	5413.7 (30.8)
Kalasthan	—	—	—	—	1275.1	1306.0	842.4	3423.5 (19.5)
Sagardwip	250.8	96.6	110.2	457.6 (2.3)	530.2	403.8	85.5	1019.5 (5.8)
Total	6930.4	5290.1	7419.0	19639.5	7924.3	5314.6	4342.5	17581.4

Figures in brackets indicate percentages to total seasonal harvest by the fishery.

fairly consistent with the effort pattern. Among the six centres, Lower Jamboodwip has led in yield followed by Upper Jamboodwip, Bakkhali and Kalisthan (Table 3). The available effort potential in the form of concentration of nets at a centre has contributed in yield pattern to a large extent. However, the difference in concentration of nets is not the sole cause of differential yields at the centres which also depends on the differential catches per unit effort at the centres. This becomes clear from a comparison of yields at Bakkhali and Fraser-gunj centres in 1985-86, the former contributing almost twice the yield with a smaller number of operating unit. The low yield and CPUE at Sagar Island the centre which was first covered during 1984-85 in comparison to other centres may be attributed mainly to the deployment of non-mechanised boats and smaller sized bag-nets. Thus with a heavier concentration of operating units the total yield at Sagar Island is the least among the centres.

In terms of availability as measured by CPUE, Lower Jamboodwip, the centre with highest average CPUE value of 252.8 kg led the other centres followed by Kalisthan, Bokkhali and Lower Jamboodwip with average CPUE ranging from 203.4 to 196.3 kg (Table 4).

Species composition: The bag-net catches mainly comprise of small-sized fishes which are carried into these nets by the tidal flow and are unable to escape out of the nets. One complete bag-net operation usually consists of the effective part of one full tide. The species-wise landings of winter migratory bag-net fishery at different centres during 1984-85 and 1985-86 are presented in Table 5. The dominant species contributing to the fishery were *Harpodon nehereus*, *Pama pama*, *Trichiurus* spp., *Setipinna* spp., *Sciaena biauritus*, *Coilia* spp. and different prawn species. These species alone accounted for 79 to 82% of the landings. Removals of these species by the winter migratory fishery constituted over 90% of the total removals of the species from the estuary during the years. The size range of several species with their mean size is presented in Table 6.

COMPARISON OF THE RESULTS WITH PREVIOUS YEARS' DATA

The winter migratory bag-net fishery has a duration of about four months and formed 71% of the total landings from the estuary during 1984-85 and 1985-86; whereas its contribution to the fishery amounted to only 29 to 33% about one and a half decade back.

TABLE - 4
Centre-wise C. P. U. E. (Kg.) in Winter migratory bag net fishery in lower estuary during 1984-85 and 1985-86

Centre	1984-85				1985-86			
	Mid. Oct & Nov. '84	December 1984	January & early Feb. '85	Average	Mid Oct. & Nov. '85	December 1985	January & early Feb. '86	Average
Frazerganj	70.33	40.52	51.71	54.18	90.39	95.33	60.87	82.20
Bokkhali	113.92	205.25	273.12	197.43	242.13	199.84	149.73	195.23
Upper Jambo	173.04	179.57	101.27	151.29	276.09	252.62	216.81	248.51
Lower Jambo	185.75	312.25	244.37	247.46	455.91	195.18	123.32	258.14
Kalisthan	—	—	—	—	246.54	242.17	121.52	203.41
Sagardwip	8.67	9.43	32.2	16.77	22.43	48.14	24.08	31.55
Average	110.34	149.40	140.53	133.43	222.25	171.21	116.05	169.84

TABLE - 5

Centre-wise contribution of dominant fish species and prawns in (t) in Winter migratory bag net fishery in lower estuary during 1984-85 and 1985-86

Name of the species	Centre-wise contribution to total catch (in t)						Total	Percentage in total catch (%)
	Frezergeranj	Bokkhali	Upper Jamboo	Lower Jamboo	Ketiathan	Sagar Island		
1	2	3	4	5	6	7	8	9
A : 1984-85								
<i>Harpodon nehereus</i>	151.2	707.8	975.6	1870.0	—	160.0	3864.6	19.68
<i>Pama pama</i>	112.1	850.6	874.0	1366.6	—	10.0	3213.3	16.36
<i>Setipinna</i> spp.	160.2	434.9	727.0	677.9	—	42.3	2042.3	10.40
<i>Trichiurus</i> spp.	92.5	758.6	140.1	3779.1	—	40.7	4811.0	24.50
<i>Sciaena blauritus</i>	—	—	—	—	—	0.3	0.3	—
<i>Coilia</i> spp.	30.0	159.0	186.1	217.4	—	8.7	601.2	3.06
<i>Tachysurus jella</i>	4.3	40.2	38.7	237.6	—	2.4	323.2	1.65
<i>Ilisha elongata</i>	15.3	85.9	52.7	175.7	—	0.7	330.3	1.68
<i>Stromateus cinereus</i>	1.1	—	5.2	—	—	0.2	6.5	0.03
<i>Polynemus paradiseus</i>	0.6	8.2	4.0	45.5	—	3.5	61.8	0.31
Prawns	94.3	229.2	376.1	727.5	—	107.9	1535.0	7.82
Others	87.0	775.9	925.9	980.1	—	80.9	2849.9	14.51
Total	748.6	4050.3	4305.4	10077.4	—	457.6	19639.4	100
B : 1985-86								
<i>Harpodon nehereus</i>	283.3	627.7	1197.1	1420.9	1170.1	191.9	4936.0	28.08
<i>Pama pama</i>	187.1	611.6	733.2	1174.2	827.1	20.8	3554.0	20.21
<i>Setipinna</i> spp.	159.5	185.0	670.0	447.4	318.2	83.4	1863.5	10.60
<i>Trichiurus</i> spp.	63.6	78.8	354.0	628.7	151.4	132.1	1408.6	8.01
<i>Sciaena blauritus</i>	3.4	40.8	242.9	95.3	176.4	10.6	569.4	3.24
<i>Coilia</i> spp.	52.9	32.7	108.2	83.7	68.9	56.0	392.4	2.23
<i>Tachysurus jella</i>	2.4	24.5	77.0	74.9	26.1	18.3	223.2	1.26
<i>Ilisha elongata</i>	3.8	15.4	24.3	117.0	39.4	0.2	200.1	1.14
<i>Stromateus cinereus</i>	1.0	8.2	44.0	47.2	6.8	0.9	108.1	0.62
<i>Polynemus paradiseus</i>	0.2	0.7	3.2	6.4	1.8	0.3	12.6	0.07
Prawns	46.8	58.7	370.6	283.4	165.7	311.3	1216.5	6.92
Others	184.9	234.3	947.9	1054.6	481.6	193.7	3097.0	17.62
Total	988.9	1963.4	4772.4	5413.7	3423.5	1019.5	17581.4	100

TABLE - 6

Mean size (mm) and range (mm) of some dominant species in winter migratory bag-net fishery

Species	Mean size	Range
<i>Harpodon nehereus</i>	217.6	80-340
<i>Pama pama</i>	115.4	20-280
<i>Setipinna phasa</i>	119.4	40-190
<i>Setipinna taty</i>	119.6	30-210
<i>Trichiurus</i> spp.	414.9	180-700
<i>Sciaena blauritus</i>	62.5	31-100
<i>Sciaena miles</i>	61.5	20-130
<i>Coilia ramearati</i>	136.0	70-270
<i>Coilia bornensis</i>	120.5	70-170
<i>Tachysurus jella</i>	87.2	50-180
<i>Stromateus cinereus</i>	62.5	41-90
<i>Polynemus paradiseus</i>	131.7	60-250
<i>Ilisha elongata</i>	166.8	101-270

The current bag net fishery (1984-85 and 1985-86) is 8 times and 4 times more than that of the period 1964-65 to 1968-69 and 1970-71 to 1974-75 respectively. The fish abundance in 1984-85 and 1985-86 winter bag-net fishery is also reflected by higher CPUE which is almost 2.5 to 3.5 times more than during the earlier periods (Table 7). This tremendous rise may be attributed to mainly the deployment of mechanised boats, large number of bag-nets under operation and involvement of larger number of fishermen in these operations during the recent years specially in Bokkhali and Jamboodwip (upper and lower) areas.

TABLE - 7

Comparative table of average nets, catch and C. P. U. E in winter migratory bag-net fishery during the period 1964 - 65 to 68-69, 1970-71 to 74-75 and 1984-85 to 1985-86.

Period	Nets (no.)	Men (No.)	Catch (t)	C.P.U.E. (kg)	Average % contribution to total annual catch of the estuary
1964-65 to 68-69	299	1120	2316.1	52.30	28.6
1970-71 to 74-75	289	1078	4152.8	71.26	32.7
*1984-85 to 85-86	530	3049	17871.9	181.98	70.0

* Excluding the centre, Sagar Island as it was not covered in earlier periods

DISPOSAL AND MARKETING OF CATCH

The catches landed during the season are mostly sundried except the economic species like Hilsa, *Hilsa ilisha*, *Polynemus paradiseus*, pomfrets (*Stromateus cinereus*) etc., which are landed in comparatively smaller quantities and are sold out locally to fish merchants in the area. The dried fishes stacked in the camps are periodically sent by boats to the marketing centres mainly to Uluberia from where further distribution to other markets takes place through dry fish traders.

DISCUSSION

The high rate of harvest of fishes by bag-net fishery is mainly due to the abundance of different fish species. This increased abundance may be due to winter blooms of plankton causing a feeding migration of fish and prawns. This induces migration of their predators as well. Large amount of organic matter, detritus and other washed off materials which are rich in nutrients are deposited below the mouth of the estuary during monsoons by the heavy inflow in the streams during that period. This brings about major food chains by inducing a rich growth of phyto-plankton during winter months. Such conditions are highly prevalent in the shallow sea-face regions of the bay where the migratory fishery operates.

The fishermen have to incur relatively heavy expenditure for sustaining themselves in these remote places. However, there are several factors which make this migratory bag-net fishery an economical venture. Prevailing calm weather conditions during winter in the extreme lower stretches of the estuary at the sea-face are highly favourable for the operation of stationary bag-nets. These conditions continue till the onset of south wind which start about the middle of February making the sea rough and the operations of these nets difficult and unsafe and the fishery comes to an end. The availability of fish vulnerable to bag-nets during November to January in the lower zone is much higher (18 to 36 times) than the average availability of fish in the upper and middle zones of the estuary during the whole year. In the upper and middle zone the average catch per unit effort remains about 0.92 to 7.27 kg during the year whereas in the winter fishery it ranges from 1677 to 258.14 kg. In upper and middle zones fishing during all the tides is not a regular feature whereas in the winter migratory fishery increasing the frequency of operations of nets is the general rule adopted.

Such a large scale drying of fish is not noticed in this estuary except at the migratory bag-net fishing centres in winter. The fishery is the mainstay of the important dry fish industry of the Hooghly estuary and supports a large

number of people directly or indirectly. Although some of the species which are caught in high abundance like *H. neherus*, *Trichiurus* spp. do not have much demand as fresh fish in the markets, there is a good market demand within and outside the country for the dry fish which are caught in appreciable quantities.

The impression that the winter bag-net fishery might have continued beyond the winter months but for the onset of the south winds, is not likely because of a number of considerations. The catch per unit of effort pattern indicates appreciable fall in February in respect of all the species and a similar situation is noticed in respect of the total catch also indicating that the margin of profit will fall appreciably in near future. Besides, the increased abundance of fish and prawn on account of plankton blooms setting in feeding migrations of fish and prawns, is also likely to decrease in the coming months, thus bringing about an end of the migratory bag-net fishery in the lower Hooghly estuary.

ACKNOWLEDGEMENT

We are grateful to Dr. A. G. Jhingran, Director of the Institute, for his encouragement and keen interest in these investigations. Thanks are also due to S/Shri A. Chowdhury, A. K. Roy,

N. D. Sarkar, N. C. Mondal, S. P. Ghosh, N. P. Saha and A. K. Banerjee, the Technical Officers of the Institute for their painstaking efforts in collection of the data,

REFERENCES

- ANONYMOUS, 1970. *Annual Report 1970*, Central Inland Fisheries Research Institute, Barrackpore.
- ANONYMOUS, 1971. *Annual Report 1971*, Central Inland Fisheries Research Institute, Barrackpore.
- ANONYMOUS, 1972. *Annual Report 1972*, Central Inland Fisheries Research Institute, Barrackpore.
- ANONYMOUS, 1973. *Annual Report 1973*, Central Inland Fisheries Research Institute, Barrackpore.
- ANONYMOUS, 1974. *Annual Report 1974*, Central Inland Fisheries Research Institute, Barrackpore.
- DATTA, P., G. C. Laha and P. M. Mitra, 1975. Exploitation of the lower zone of the Hooghly by migratory fishing units. *J. mar. biol. Ass. India*, 17 (3): 580-599.

THE SHRIMP RESOURCES OF THE COASTAL WATERS OF KERALA AND THE EFFECT OF MECHANISATION

M. J. George
Girinager, Cochin

ABSTRACT

The exploitation of shrimp resources in the coastal waters of Kerala by mechanised and traditional sectors together is limited to the 80 m depth zone in the continental shelf. Indications are that the shrimping grounds inside this depth zone all along the coast are being exploited to the maximum level, possibly by a combination of effort from the two sectors, except perhaps a few areas which are unreachable from the existing port facilities by the small mechanised vessels capable of only single day operations.

The trend in shrimp production right from the time of initial introduction of mechanisation using the shrimp trawls in the fifties through 1985 has been studied to assess the resource situation from an overall total shrimp production view point as well as the part played in the production by the two sectors. The total production which was less than 15,000 tonnes before the introduction of mechanisation rose up to the maximum of nearly 85,000 tonnes in 1973 and there after declined to an average of 30 to 40 thousand tonnes in recent years with fluctuations. The analysis of production data from important centres of fishing operations also shows a similar trend. Thus it is becoming more and more evident that a decline and stagnation has set in as far as the shrimp fishery of the coastal zone is concerned, inviting urgent measures for conservation of fishery in the area.

A comparative study of shrimp production data of the traditional sector and the mechanised sector shows that while the catches of the former decreased considerably, that of the latter increased over the years, resulting in the present conflict between the two sectors. This raises various management problems for the fishery and some of the management measures which could be adopted with reference to the total fishery as well as the fishery at important centres are discussed.

INTRODUCTION

It is a well known fact that the major part of the shrimp production in India comes from the west coast and in this a substantial portion, contributed by the south west coast, is from Kerala coastal waters. In order to meet the insatiable demand for shrimps from the export industry all possible measures are being explored for the maximum exploitation of the shrimp resources in these coastal areas. Mechanisation of the fishery and shrimp trawling is the most important development for this increased exploitation of the resources. Shrimp trawling has, no doubt, contributed to a conspicuous increase in production over a decade. However, in recent years the indications are that a stage has been reached where the total production is not showing much of an increase, but staying almost at a stagnant level.

The stagnation in production of the resource may be brought about by various reasons, among which may be mentioned limitation in the available resources, indiscriminate input of increasing effort in the fishery, variations in the environmental factors etc. A combination of all these factors or any one of these may be the causative factor for the decline or stagnation in production level. Added to these both mechanised and traditional sectors operating side by side and exploiting more or less the same resources makes the situation worse. Therefore a detailed analysis of the trends in production over the years, especially with reference to mechanisation is necessary to decide about the proper management measures to be taken in the maintenance of the fishery at the optimum level and the present contribution is an attempt in this direction.

TRENDS IN PRODUCTION

The shrimp production in Kerala State which was less than 15,000 tonnes in the years 1959 and 1960 rose to nearly 85,000 tonnes in 1973 and thereafter declined and in recent years it averaged, between 30,000 and 40,000 tonnes. The trend in triennial average catch shows an increase of little over 100% from 1959-61 to 1974-76 (Fig. 1). After this there is a decline in the percentage increase from the 1959-61 base level by 30% in 1983-85. From the year 1976 to 1985 the catch has declined from the level of 1973-75 and a stagnation with minor fluctuation from year to year at about 35,000 tonnes is noticed.

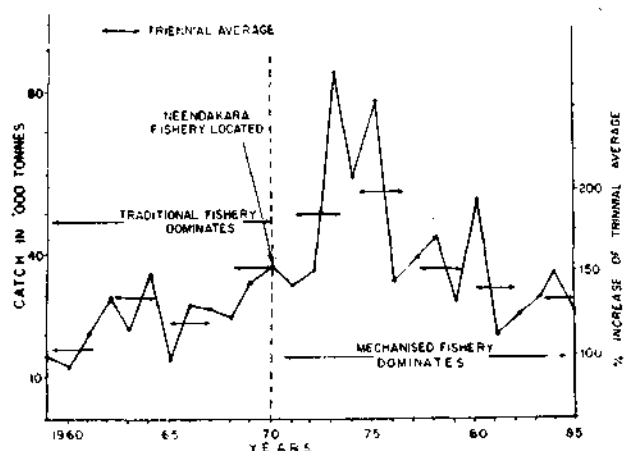

Fig. 1. The triennial averages of shrimp catches during 1960-85.

While analysing the production trends of shrimps of Kerala State it has to be borne in mind that two sectors are operating side by side in the coastal waters, namely, the mechanised sector and the non-mechanised or traditional sector, more or less exploiting the same resource. The production of shrimps of both of these sectors needs to be considered separately in order to understand the problems in the fishery. The mechanised trawl fishery is concentrated mostly along centres where landing facilities for small boats are available along the coast and the artisanal fishery is operating in all areas of the coast. From the details given in Table 1 it is clear that Neendakara is by far the most important centre along the Kerala coast where the maximum quantity of shrimp is landed by the mechanised trawl fishery. The fishery limited to the monsoon months June to September is constituted by a single species, namely *Parapanaopsis stylifera* (Karikkadi Chemmeen) and contributes to nearly 80% of the total shrimp production of the state in the mechanised sector.

The species composition and other biological features of the resources are well documented (George, 1961; George *et al.*, 1963; Kurup & Rao, 1975; George *et al.*, 1980; George *et al.*, 1983; Alagaraja *et al.*, 1986 etc.). Therefore it is

TABLE 1.

Shrimp catches at important shrimp trawl operation centres of Kerala from 1970 to 1984

Year	Centres							Total shrimp catch of trawl nets (Tonnes)
	Neendakara		Cochin		Calicut		Other centres catch	
	Catch (Tonnes)	Catch hour in kg	Catch Tonnes	Catch/hr in kg	Catch (Tonnes)	Catch/hr in kg	Tonnes)	
1970	1,845	12.6	2,200	22.0	1,300	18.1	4,400	9,745
1971	11,004	39.8	3,850	6.1	1,050	11.5	3,200	19,104
1972	11,267	23.4	2,150	11.7	200	11.4	3,810	17,427
1973	45,477	82.6	6,000	21.1	625	8.3	6,925	59,027
1974	27,764	33.7	3,900	11.6	420	7.0	5,720	37,804
1975	53,750	42.6	7,200	20.9	570	7.7	7,280	71,800
1976	14,993	27.9	2,800	10.0	235	2.8	1,672	19,700
1977	21,120	18.0	5,300	14.0	340	4.1	4,440	34,200
1978	33,143	13.7	2,160	4.0	230	4.4	3,353	38,886
1979	14,582	20.1	3,350	9.4	330	4.9	6,250	24,512
1980	36,558	43.1	3,500	12.9	380	6.8	5,723	46,161
1981	9,399	17.7	2,550	47.5	112	3.9	424	16,305
1982	9,425	16.2	2,957	16.3	217	30.2	8,738	20,977
1983	8,174	12.3	3,977	22.2	275	9.2	10,673	23,099
1984	14,575	19.5	2,357	16.2	214	9.9	7,825	24,971

not proposed to go into those details in the present contribution. However, it may be mentioned that among the five species contributing to the shrimp fishery in general in the coastal waters of the State, a shift in the dominant species from *Metapenaeus dobsoni* to *Parapenaeopsis stylifera* has been noticed in recent years. Also there is a general trend of more of smaller sizes of these shrimps coming into the fishery recently in all the Centres where the mechanised boats are concentrated.

PRODUCTION IN MECHANISED AND TRADITIONAL SECTORS AND THE EFFECT OF MECHANISATION ON THE FISHERY

The origin of mechanisation in the shrimp fishery of Kerala State may be traced back to the early fifties when the Indo-Norwegian Project was established at Neendakara in Quilon. Initially the traditional nets of the fishermen like the drift nets and gill nets were operated from small vessels with inboard engines. In due course small shrimp trawls operated from the 25 feet boats with 15 hp engines brought in big catches. Slowly private industry and entrepreneurs came into the picture in different areas of the coast and the mechanised trawl fishery came to stay in Kerala State. With the increase in catches of shrimps by these vessels every year more and more of these small mechanised vessels were introduced into the fishery and at present nearly 3,000 such vessels are enumerated in these coastal waters.

A comparative picture of the shrimp fishery of the traditional sector and the mechanised shrimp trawl fishery in Kerala may be seen in Fig. 2. Over the years side by side with the increase in shrimp catches by the shrimp trawls, a gradual decrease in the shrimp catches in the traditional sector is very much evident. This reduction in the shrimp catches by the traditional sector in the overall shrimp fishery of the State is all the more conspicuous when the percentage contribution of the traditional shrimp fishery to the total shrimp catches is considered. It fell from 96.5% in 1962 to an average of 15.5% in 1977-80 period and 24.2% in 1980-85 period. From this the natural conclusion which follows is that the mechanised fishery has

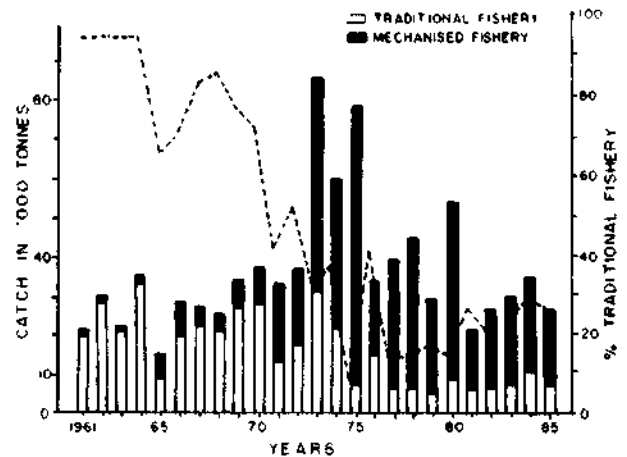

Fig. 2. Comparison of shrimp productions of the two sectors from 1961 to 1985.

adversely affected the traditional shrimp fishery of the State.

If we look at the figures a little closer it is clear that upto the year 1970 it is the production from the traditional fishery which is dominant and after 1970 the production by the mechanised trawl fishery dominates. From 1970 there is a sudden boost in the total catches contributed mostly by the phenomenal increase in the catches of the mechanised trawl fishery, as indicated in Fig 1. The reason for this is that it is in 1970 the shrimp trawl fishery at Neendakara was located and the subsequent few years show very high production from this Centre, which is reflected in the total production of shrimps (Table 1). However, it is noticed that by 1980 the production from that Centre goes down considerably, which again is reflected in the overall production. Still the dominance of the mechanised fishery in the total shrimp landings persists, although the total shrimp catch has declined and reached the level of the pre-1970 period.

Two important points emerge from the facts mentioned above. Firstly, in general the total production of shrimps from Kerala coastal waters has decreased considerably in the past few years. Secondly, while the production of shrimps by the mechanised trawl fishery has increased and eventually gone down in recent years, the production of shrimps from the traditional sector has deteriorated considerably over the years. It would appear that the shrimp trawl fishery of the coastal waters has prospered at the expense

of the catches of the traditional fishery. This is quite understandable since both the fisheries are based on the same resource from more or less the same grounds.

DISCUSSION

These disturbing tendencies in the shrimp production of the State raise serious management problems for the fishery and at the moment this is the most important aspect requiring attention of the fishery administrator and manager, the situation becoming all the more serious as the two conflicting interests are showing up the ugly faces of fights and quarrels between the two sectors. The position here is that the traditional sector is also growing up side by side with the mechanised sector. According to the census conducted by CMFRI (1981) and quoted by Thankappan Achari (1986) there is a rise of 63% in the total number of fishermen (of which the major portion is engaged in the traditional sector) from the census conducted in 1961/62. There is also a rise in the number of traditional crafts including catamarans, dug out canoes and plank built boats from 11,480 to 26,271 numbers, indicating the phenomenal growth in the sector. The only proper management solution for the problem seems to be limiting the areas of fishing grounds for particular fishery and also limiting the input of effort. This is what the State Government was trying to execute by the Marine Regulation Act, limiting depth zones for operation of the vessels of the two sectors. The consequent developments involving conflicts between the two sectors, the setting up of the Babu Paul Commission and later the Kalawar Commission and their reports in 1982 and 1986 respectively are well known.

Among the many reasons which could be attributed to the decline in the catches of both sectors the most important seems to be the limitation in the shrimp resources in the inshore coastal waters of the State. Along these coastal waters almost all the landings are from within the 50-60 m depth zone. Even in this depth zone the most productive areas are within the 25-30 m depth region according to reports available (George et al., 1983). Reports from the recent research cruises of research vessels as

well as exploratory fishing operations indicate the same results. The crafts and gears of both mechanised and artisanal sectors, therefore, operate in more or less the same areas in which the resources are available and the more efficient gear for catching the bottom living shrimps obtain better catches.

All these things point to the necessity for developing a suitable management policy which would ensure profitable shrimp fishing operations for both mechanised and traditional sectors side by side. Among several conservation measures available for managing a fishery a combination of two measures seems to be best suited for proper management of the shrimp fishery under the circumstances described. The two measures are temporary closures of the fishery during certain months and limitation of input of effort along with specification of areas of operation for particular sectors. As far as the shrimp trawl fishery of the mechanised vessels off the coastal waters of Kerala was concerned the south west monsoon season traditionally acted almost as a closed season for the fishery, so that another closed season was not necessary. Naturally enough this stoppage of the fishery due to the monsoon rains and stormy weather takes place at a time when the mean sizes of all the species in the fishery are at the lowest and the absence of fishing operations for two or three months at that time acted as a natural conservation measure. But at Neendakara, the most important shrimp trawling centre of Kerala, the maximum fishing operations are carried out during the monsoon period with the maximum landings. The question arises whether the closure or ban of fishing during the monsoon season should be enforced here also. The answer to this question depends on whether the entire stock of shrimps appearing suddenly in the fishery there at that particular time will be lost to the fishery if not fished at that time or will these shrimps be available to the fishery there itself or in adjacent areas in bigger sizes in the subsequent months? The only way to prove this point is to apply an experimental closure for one or two years during those particular months and study the results.

The other measure, namely the limitation of fishing effort is equally important in the circum-

stances of the shrimp fishery of Kerala. When the available shrimp resources in the fishing grounds are subjected to increasing exploitation by introduction of more and more fishing effort, a stage would be reached when further input of effort would result in uneconomic returns and this is at present happening in the shrimp fishery of Kerala. Therefore, a limitation in the input of effort, by reduction in number of units and by fixing a catch limit for particular units in order to limit the total catch to the optimum level of sustainable yield may be adopted. In the circumstances of the shrimp fishery of Kerala where the mechanised and traditional fishery are exploiting the same resource, specification of areas of operation for the particular fishery would also be necessary.

REFERENCES

- ALAGARAJA, K., M. J. GEORGE, K. NARAYANA KURUP AND C. SUSEELAN 1986. Yield-per recruit analyses on *Parapenaeopsis stylifera* and *Metapenaeus dobsoni* from Kerala State, India. *J. Appl. Ichthyol.* 2 (1986) : 1-11.
- CMFRI 1981 All India census of marine fishermen, craft and gear: 1980. *Mar. Fish. Infor. Serv. T & E Ser.* 30 : 2-32.
- GEORGE, M. J., 1961 Studies on the prawn fishery of Cochin and Alleppey coast. *Indian J. Fish.* 8 (1) : 75-95.
- GEORGE, M. J., K. RAMAN AND P. K. NAIR 1963 Observations on the off shore prawn fishery of Cochin. *Indian J. Fish.* 10 (2) : 460-499.
- GEORGE, M. J., C. SUSEELAN, M. M. THOMAS AND N. S. KURUP 1980 A case of overfishing: Depletion of shrimp resources along Neendakara coast, Kerala. *Mar. Fish. Infor. Serv. T & E Ser.* 18 : 1-8.
- GEORGE, M. J., C. SUSEELAN, M. M. THOMAS N. S. KURUP, K. N. RAJAN, V. S. KAKATI, K. N. GOPALAKRISHNAN, K. CHELLAPPAN, K. K. BALASUBRAMANYAN AND C. NALINI 1983 Monsoon prawn fishery of Neendakara coast, Kerala - A critical study. *Mar. Fish. Infor. Serv. T & E Ser.* 53 : 1-8
- KURUP, N. S. AND P. V. RAO 1975 Population characteristics and exploitation of the important marine prawns of Ambalapuzha, Kerala. *Indian J. Fish.* 21 : 183-210.
- THANKAPPAN ACHARI, T. R. 1986 Marine fish production in Kerala - A review. (in Malayalam). Published by P. C. O. Centre, Trivandrum.

SHRIMP FISHERY OF BOMBAY COAST

M. Aravindakshan and J. P. Karbhari
Central Marine Fisheries Research, Institute, Cochin-31.

ABSTRACT

With the introduction of the mechanised trawlers, the shrimp fishery of Maharashtra coast especially of Bombay region has shown considerable variations both in species composition and in the magnitude of the landings. A study was therefore made for a five year period from 1982-1986 to understand the trend of prawn fishery. Two important centres namely Versova and Sassoon dock were selected to cover the mechanised 'Dol' fishery and trawl fishery respectively. The results are presented alongwith the problems of management when mechanisation is on the increase enabling the fishermen to explore deeper areas hitherto not fished at all.

INTRODUCTION

The shrimp fishery of Bombay coast has been studied by many workers earlier. A detailed account of the fishery of the region has been given by Shaikmohamed and Tembe (1960), Kunju (1967), Mohamed (1967), Kagwade (1967) Rao *et al* (1966, 1968), Aravindakshan and Karbhari (1983) and Chakraborty *et al* (1983). These authors have reported the different aspects of the shrimp fishery by the traditional 'Dol' nets and the modern trawl nets. A recent study by Aravindakshan and Karbhari (1983) indicates that penaeid prawns earlier reported to have no fishery value are entering the fishery adding additional varieties to the fishery. A study of the trawler catches at Sassoon dock for penaeid prawns and 'Dol' net catches at Versova for bag net landings for penaeid and non-penaeid prawns are presented in this paper, to understand the trend of the landings by the respective gear and also managerial problems that may arise due to landing of new varieties hitherto fished little, or not at all.

MATERIAL AND METHODS

The fish landing centres were visited once a week for observation of landings and collection of samples for biological studies in the laboratory later.

The survey data collected by the field staff of the centre and processed have also

been utilised for detailed analysis and presentation.

Craft and gear:

Craft and gear for the fishery are the same described by Chakraborty *et al* (1983). The area of fishing extends up to Ratnagiri in the south from Bombay base for trawlers and for 'Dol' nets off Versova coast up to a depth of 40 m.

Fishing season

At Versova complete suspension of fishing is observed from first week of June to the end of August. The trawl operations are continuous at S. dock though suspended for a few days when weather conditions are unfavourable during monsoon months.

Fishery:

The total landings at both centres for the five year period are given for S. dock and Versova (Fig. 1). Only penaeid prawn landings are considered for S. dock while both penaeids and non-penaeids are noted for catch data at Versova. This is due to the fact that non-penaeids by trawl nets at S. dock are represented only during some months.

Catch trend of penaeids at S. dock, as given in Table 3 shows only small deviations except for years 1983 and 1984, when highest and lowest landings are recorded.

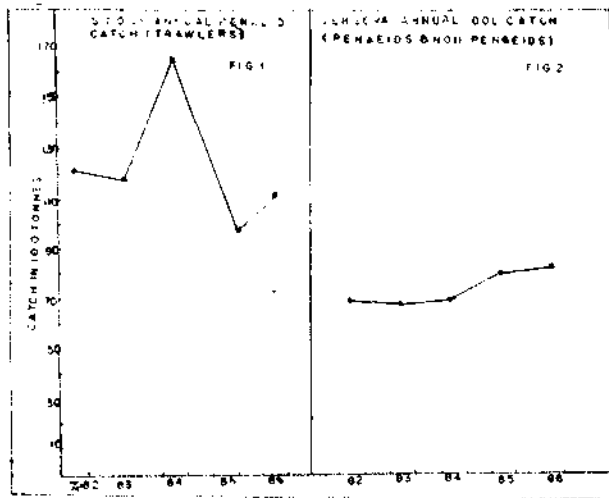

Fig. 1. Catch trend of prawns at S. dock and Versova

Catch per unit effort during these two years does not show deep deviations. The average c.p.u.e. works out to be 23.1kg/hr. The percentages of penaeids in total fish also do not show significant variation indicating that degree of exploitation is stable.

At Versova (table 3) the catch shows a steady trend for three years from 1982 to 1984 and an increase in catch for 1984 and 1985. With regard to c.p.u.e. the same trend is maintained. Highest c.p.u.e. is registered in 1986 and the lowest in 1983, the average for the five years being 53.9 kg/hr. From the trend of fishery with regard to total landings and c.p.u.e. it appears that exploitation is steady for 'Dol' fishery at Versova during the period of study.

Major species that contribute to the fishery

The major species that contribute to the fishery at S. dock and Versova are listed below as they are important for management.

S. dock Trawl

1. *Metapenaeus affinis*
2. *M. monoceros*
3. *Parapenaeopsis stylifera*
4. *M. brevicornis*
5. *Solenocera crassicornis*
6. *S. chopora*
7. *Metapenaeopsis stridulans*
8. *M. hilraula**
9. *Parapenaeus longipes*
10. *Trachypenaeus longipes*
11. *Penaeus japonicus*
12. *M. dobsoni**
13. *P. penicillatus*
14. *P. monodon*
15. *P. semisulcatus**
16. *Atypeopenaeus stenodactylus*
17. *Parapenaeus stenodactylus*
18. *P. hardwickii*

Versova (Dol)

1. *M. affinis*
2. *M. monoceros*
3. *P. stylifera*
4. *M. brevicornis*
5. *S. crassicornis*
6. *M. stridulans*
7. *M. stenodactylus*
8. *P. penicillatus*
9. *P. sculptilis*
10. *P. hardwickii*
11. *P. japonicus**
12. *Acetes indicus*
13. *A. johni*
14. *A. japonicus**
15. *Nematopalaemon tenuines*
16. *Exhippolysmata ensirostris*
17. *Exopalaemon styliferus*

TABLE 1

Percentage of major penaeid prawns in Trawler catches at Sasoon dock

Species	(Annual average)				
	1982	1983	1984	1985	1986
<i>Penaeus</i> spp	4.1%	2.6%	4.3%	6	4
<i>Metapenaeus affinis</i>	20.5	36	23.2	24	23
<i>M. monoceros</i>	22.4	10.4	15	23.7	15
<i>M. brevicornis</i>	5	2	3	4.6	3
<i>Parapenaeopsis stylifera</i>	26.9	38	47	29.4	47
<i>Solenocera</i> spp	10.6	6.2	2.6	3.7	2
<i>Metapenaeopsis stridulans</i>	4.4	2.3	4	7.8	5
<i>Parapenaeus longipes</i>	1.4	.5	0.5	0.4	0.5
Misc	4.7	2	0.5	0.4	0.5

TABLE 2

Percentage of major prawn species in 'dol' catches at Versova
(Annual average)

Species	1982	1983	1984	1985	1986
<i>Acetes</i> sp	69.0	70.0	70.6	65.2	55.0
<i>Nematopalaemon tenuipes</i>	18.0	16.9	18.1	18.2	31.2
<i>Parapenaeopsis stylifera</i>	4.0	5.6	3.4	7.1	3.7
<i>Solenocera crassicornis</i>	3.4	3.1	3.1	5.1	4.8
<i>Exhippolysmata encrostris</i>	1.6	2.9	3.1	0.8	0.4
<i>Parapenaeopsis sculptilis</i>	0.9	0.9	0.8	0.5	2.6
<i>Parapenaeopsis hardwickii</i>	1.0	0.1	—	1.0	0.9
<i>Metapenaeus brevicornis</i>	0.4	0.05	0.2	0.8	0.6
<i>Metapenaeus affinis</i>	0.3	—	—	0.6	0.5
<i>Penaeus monodon</i>	0.5	0.2	—	—	—
<i>Penaeus penicillatus</i>	0.4	0.2	—	—	—
Miscellaneous	0.5	0.05	0.7	0.8	—

TABLE 3

Consolidated catch with c. p. u. e. for 1982-1986 (Sasoon dock & Versova)

	Units	Total prawn catch (Kg) with c. p. u. e. in paranthesis	Total Fish (Kg)	Prawn percentage total fish (%)
<i>S. dock (Trawl net)</i>				
1982	24689	12216308(20.6)	47640015	25.5
1983	28505	11766860(17.2)	25587367	45.9
1984	21045	16664427(33)	33946410	49.1
1985	20447	9825239(20.0)	27217544	27.7
1986	18902	11261838(24.8)	33432834	33.6
Total	113588	61734672 (23.12 average)	197924170	36.4 (average)
<i>Versova (Dol net)</i>				
1982	14620	6919386(47.37)	12243181	56.5
1983	16848	6719691(41.8)	14784448	44.5
1984	14851	6919386(46.5)	12243181	56.5
1985	12974	8547529(65.8)	12701856	67.2
1986	12852	8754952(68.1)	24013265	36.5
Total	71345	37860944 (average)	75985931	52.2 (average)

Yearwise percentage composition of different species have been given in tables 1 and 2. It can be seen from the tables that the percentage composition of penaeid prawns in trawl fishery is dominated by *P. stylifera* *M. affinis* and *M. monoceros* and *Solenocera* spp. (*S. crassicornis* and *S. choprai*) respectively followed by other penaeid species. For Versova 'Dol' landings are dominated by *Acetes* spp (mainly *A. indicus* and *A. johni*) followed by *N. tenuipes*. These two groups are found to contribute to more than 80% of 'Dol' catches at Versova.

This finding is also close to the report of Rajan *et al* (1982) with regard to percentage of non penaeids contributing to 'Dol' fishery at Versova. Major penaeids that are found to support the 'Dol' fishery are *P. stylifera* and *S. crassicornis*. These two species formed about 7-12% of 'Dol' catches. *A. sibogae* though forms a fishery at Trombay 'Bag net' (Machardani) is not noticed in the present study.

The studies reveal that the trends of penaeid prawn landings at Sassoon dock do not show sharp decline in the catches requiring restrictions of mesh size of trawl nets and hours of effective fishing. In the case of 'Dol' fishery a slight change in species dominance noted by Rajan *et al*, (Op. cit) is found to be persisting. Appearance of *A. johni* as a dominant contributor to the fishery also calls for fresh studies on *Acetes* populations in the area for the purpose of management.

ACKNOWLEDGEMENT

The authors are deeply thankful to Dr. P. S. B. R. James, Director of Central Marine Fisheries Research Institute, Cochin for his kind interest in the preparation of this paper presented at the symposium.

REFERENCES

- ARAVINDAKSHAN, M. AND J. P. KARBHARI 1983. Kuruma shrimp fishery from Bombay waters. *Mar. fish. infor. serv. T & E Ser.* 47 9-12.
- ARAVINDAKSHAN, M AND J. P. KARBHARI 1983. New penaeid prawn resources showing along Maharashtra coast. *Ibid.*, 58 : 10-13.
- CHAKRABORTY S.K, V.D. DESHMUKH, KUBER VIDYASAGAR AND S. RAMAMURTHY 1983 By-catch of shrimp trawlers in greater Bombay. *Ibid.*, 54 : 7-15.
- KAGWADE, P. V. 1965. Prawn catches of mechanised vessels in the trawling grounds of Bombay and Saurashtra. *Proc. Symp. Crustacea. Mar. biol. Ass. India* 4 : 1548-1381.
- KUNJU, M. M. 1967. Observations on the prawn fishery of the Maharashtra coast. *Ibid.*, 1382-1397.
- MOHAMED. K. H. 1967. Penaeid prawns in the commercial shrimp fisheries of Bombay with notes on species and size fluctuations. *Ibid.*, 1408-1418.
- RAO, K. VIRABHADRA, P. T. MEENAKSHI-SUNDARAM AND K. DORAIRAJ 1966. Relative abundance of trawl fishes in the Bombay and Saurashtra waters. *J. Mar. Biol. Ass. India.* 8 : 205-212.
- RAO, K. VIRABHADRA, K. DORAIRAJ, P. V. KAGWADE AND D.M. PUNWANI 1968. Results of the exploratory fishing operations of the Govt of India vessels at Bombay base for the period 1961-67. Symposium on Demersal Fisheries 13th Session, Brisbane Australia, preprint *IFPC C 68/Svm.* 28.
- RAJAN, K. N., K. K. SUKUMARAN AND S. KRISHNA PILLAI. 1982. On 'Dol' net prawn fishery of Bombay during 1966-76. *Indian J. Fish* 29 (1 & 2) : 29-36.

NATIONAL STRATEGY FOR EXPLOITATION AND UTILIZATION OF THE POTENTIAL MARINE FISHERY RESOURCES OF INDIA - A PROJECTION

P. S. B. R. James, T. Jacob, K. C. George, V. Narayana Pillai,
K. J. Mathew and M. S. Rajagopalan
Central Marine Fisheries Research Institute, Cochin

It is more than a decade since the country declared in 1977 its maritime Exclusive Economic Zone covering an area of 2.02 million sq. km, thus inheriting a great wealth of living and non-living marine resources. The potential of marine fishery resources of the EEZ is of considerable magnitude and roughly estimated at 4.5 million tonnes based on different approaches by scientists. As against this, during the last one and a half decades there has not been any substantial increase in the marine fish production of the country which currently stands at about 1.6 million tonnes. The fact that a large gap exists between the potential resources and the actual yield is a matter of great concern.

Despite, increasing demand for fish and prawns in the internal and export markets, the industry has remained dormant and has not come forward to make large investments in new areas of fisheries and thus diversify their efforts. This is attributed to the lack of critical information on the presently exploited stocks as well as the potential resources which are remaining unexploited. The exploited resources, some of which having a high unit value, require rational exploitation and judicious management, whereas the presently untapped offshore and oceanic resources need be exploited to the optimum level. Besides the need for precise information on the potential resources, much work remains to be done on the harvest and post-harvest technologies. Information on existing infrastructure and those needed for future requirements, economics of operation of various types of mechanised vessels, marketing facilities etc. is much wanting.

The time is ripe now for evolving a national strategy for exploitation and utilization of the resources of the EEZ, so that proper direction and support could be given to fisheries development programmes involving production and utilization.

The aim of the present document is to provide the background information on exploited marine fishery resources, group-wise potential resources, existing infrastructure, and give projections for additional exploitation of resources in the shelf and slope areas and utilization.

EXPLOITED MARINE FISHERY RESOURCES

The estimated annual fish landings (averaged over the 3 years 1983 to 1985) work out to 1.56 million tonnes. Almost 98 per cent of these landings is accounted for by the coastal fisheries limited to a depth of 50 m. The crafts operated are the small mechanised vessels (trawlers, purse-seiners, gillnetters, dolnetters and boats fitted with out board motor where mechanisation is used for propulsion and fishing or propulsion alone) and the artisanal units. Information on catches of larger vessels operated by the private industry is practically not forthcoming even though concerted efforts were made by the Institute in the past to secure them. However, assuming even a liberal figure, it will be contributing only less than two per cent of the total landings.

Table I gives the average annual region-wise and species-wise composition of the fish landings during the years 1983-'85. About 11.0% of the landings is accounted for by oil-sardine followed by *penaeid* prawn

TABLE - 1

Regionwise and specieswise annual fish landings in India in tonnes
(average of 1983 to 1985)

Species	Region	Northwest	Southwest	Lowereast	Uppereast	Total
Elasmobranchs		23769	10658	13889	11600	59916
Eels		6608	31	227	840	7706
Cat fishes		22194	16382	3681	12081	54338
Chirocentrus		9295	1756	2539	3234	16824
Oil sardine		1079	160439	2615	300	164433
Lesser sardine		645	11395	30675	25717	68432
<i>Hilsa ilisha</i>		1029	135	652	4525	6341
Other <i>Hilsa</i>		6270	21	4805	4819	15915
<i>Anchoviella (Stolephorus)</i>		1878	53959	11263	5828	72938
Other clupeids		33535	15136	14398	18516	81585
<i>Harpodon nehereus</i>		106297	8	4	3795	110104
<i>Saurida saurus</i>		3571	7181	2190	1501	14443
<i>Hemiramphus & Belone</i>		300	701	1048	154	2203
Flying fish		1	24	1708	70	1803
Perches		13660	26998	13976	11368	66002
Red mullets		1410	143	2207	1506	5266
Polynemids		4775	1268	438	1860	8341
Sciaenids		52434	16558	11783	26236	107011
Ribbon fish		24507	8539	8480	12171	53697
Carangids		8740	22378	14288	8790	54196
Silverbellies		948	11151	47828	7239	67166
<i>Lactarius</i>		14111	3712	602	755	19180
Pomfrets		29419	3925	988	11730	46062
Mackerel		792	29195	7211	7039	44237
Seer fish		10390	12226	4926	7886	35428
Tunnies		6260	12549	2053	1374	22236
<i>Sphyraena</i>		415	1134	1583	477	3609
<i>Mugil</i>		2817	388	453	426	4084
<i>Bregmaceros</i>		1172	6	—	—	1178
Soles		8268	20786	2386	1374	32814
P. prawns		55045	41975	13939	12414	123373
N. P. prawns		50315	348	658	7938	59269
Lobster		2251	85	471	23	2830
Other crustacens		14682	22976	9679	3262	50599
Cephalopods		12472	6046	4071	1269	23858
Misc.		17408	13036	22246	4439	57129
TOTAL		548762	633258	259960	222556	1564536

(7.9%), Bombay duck (7.0%), Sciaenids (6.8%), *Stolephorus* (4.7%), lesser sardines (4.4%), silverbellies (4.3%), perches (4.2%), non-penaeid prawn (3.8%), elasmobranchs (3.7%), cat fishes (3.5%), carangids (3.5%), ribbon fishes (3.4%), pomfrets (2.9%), mackerel (2.8%), seer fishes (2.3%), soles (2.1%), cephalopods (1.5%) and tunnies (1.4%).

As seen from Table 1, the northwest region (comprising Maharashtra and Gujarat coasts) contributed 35% to the total landings, southwest region (comprising Goa, Karnataka, Kerala and Lakshadweep) 34%, lower east region (comprising Tamil Nadu and Pondicherry) 17% and upper east region (comprising Andhra Pradesh Orissa, West Bengal and Andamans) 14%.

The dominant species caught in the northwest region are Bombay duck (19.4% of region's total), penaeid prawns (10.0%), sciaenids (9.6%), and non-penaeid prawns (9.2%). In the southwest region 30.0% of the landings is oil sardine, 10.0% *Stolephorus*, 8.4% mackerel and 7.9% penaeid prawns. Silverbellies formed the major component in the lower east region landings (18.4%) followed by lesser sardines 11.8% and perches, penaeid prawns and elasmobranchs (about 5.4% each). In the upper east region the important species landed are sciaenids (11.8%), lesser sardines (11.6%), penaeid prawns (5.6%), ribbon fishes (5.5%), cat fishes (5.4%), elasmobranchs (5.1%) and perches (5.0%).

POTENTIAL RESOURCES

As stated earlier the production of marine fish in the country during the last few years remained more or less the same with fluctuations in the catch of some of the major groups. In the past, estimates of potential yield have been made by several authors based on primary production, exploratory surveys and catch rate and effort. Thus Jones and Banerji (1973) estimated potential yield at 2.5 million t. The National Commission on Agriculture (Anon., 1976) estimated a production of 3.5 million t after 25 years.

With the declaration of the EEZ a revised estimate of the potential yield has been made according to which the annual yield could be 4 million t (Silas *et al.*, 1976) and 4.47 million t (George *et al.*, 1977). While the estimated harvestable fish potential showed a figure of about three times of the present yield it is felt that further increase in marine fish catches could come mainly from deep water or distant water fishing of under-exploited fish resources in the EEZ. Based on the estimates by George *et al.* (1977), the total exploitable resources upto 200 m depth zone is 2.30 million t from the west coast, 0.09 million t from the Lakshadweep and 0.16 million t from the Andaman & Nicobar islands. Besides, 0.5 million t of oceanic resources from all regions beyond 200 m depth zone could also be exploited.

Pelagic resources

It is estimated that the potential pelagic stock is 1.77 million tonnes (Table 2) as against the yield of about 0.7 million t. Among the exploited pelagic resources the most important group expected to contribute to significant additional yield is that of whitebait, especially from the Gulf of Mannar during July-September and from the southwest coast during October-December. The total potential of this category from the EEZ is estimated to be 0.24 million t as against the current yield of 73,000 t. The magnitude of additional yield will be about 0.15 million t within 20-50 m depth. The efficient gears for tapping this resource would be the small purse seine and mid-water trawl.

Carangids comprising of horse mackerel, scads and trevallies are estimated to have a potential stock of 0.27 million t against the current yield of 54,000 t. Additional yield to the tune of 0.2 million t could be expected from these resources. Grounds for this group have been located along the southwest coast, off Gujarat and upper east coast at a depth between 50-125 m. Apart from mid-water trawling, these resources can also be harvested by purse seines and drift gill nets.

Ribbon fishes of the estimated potential of 0.27 million t would yield considerable additional quantities from 20-80 m depth from the southwest, lower east and northwest coast.

TABLE - 2
Estimated potential yield ('000 t) of different groups

	N.W. Coast	S.W. Coast	L.E. Coast	U.E. Coast	AN Lab	Total PY
A. Demersal						
Elasmobranchs	45	45	35	40	20	185
Cat fishes	90	120	25	75	—	310
Perches	30	120	75	15	10	250
Polynemids	10	—	5	25	—	40
Sciaenids	70	20	20	100	—	210
Leiognathid	—	15	55	30	—	100
Pomfrets	30	—	15	40	—	85
	275	320	230	325	30	1180
B. Pelagic						
Oil sardine	5	180	—	10	—	195
Other sardine	5	40	70	15	10	140
Anchoviella	—	160	80	—	—	240
Other clupied	55	10	40	45	15	165
Ribbon fish	90	110	45	25	—	270
Carangids	70	110	25	60	—	265
Mackerel	5	80	15	—	5	105
Seer fish	5	10	15	10	5	45
Bombay duck	80	—	—	20	—	100
Tunas & related sp.	10	60	10	10	150	240
	325	760	300	195	185	1765
C. Shell fish						
Penaeid prawn	30	95	20	35	—	180
Non penaeid prawn	90	—	5	10	—	105
Other crustaceans	5	10	20	5	—	40
Cephalopods	20	35	20	100	5	180
Other fishes	135	200	85	70	30	520
Total (A+B+C)	880	1420	680	740	250	3970
+ Oceanic fishes	—	—	—	—	—	500
						4470

Boat seine and trawl net are the suitable gears for the species.

Oil sardine, the most important coastal pelagic species caught in the country is presumed to be optimally exploited, while marginally the Indian mackerel may support some additional catches. However in the present account it is not considered as a significant resource for any substantial additional production.

The small tunas show a potential of 0.1 million t in Andaman waters and 50,000 t in

Lakshadweep beyond 100 m depth and about 90,000 t along the mainland coast beyond 50 m depth. Introduction of large purse seine and suitable drift gillnet would help in tapping this resource. At present there is only marginal exploitation of oceanic resources. The total oceanic tuna potential of the EEZ is estimated to be around 0.5 million t consisting mainly of yellowfin, bigeye and oceanic skipjack. Sailfish, marlin and oceanic pelagic sharks also form an extra component. Recent longline operations of FSI (Joseph and John, 1986) and CIFNET (Swaminath et al., 1986) have indicated the

richness of these resources along the deeper shelf areas of the west coast.

Demersal resources

The estimated potential of demersal finfish resources of the EEZ is around 1.1 million t as against the total current yield of 0.41 million t.

Cat fishes promise the maximum additional resource with potential of 0.31 million t against the present yield of 54,000 t. Productive fishing grounds have been located along the upper east coast, northwest coast and southwest coast between 20 and 100 m depth ranges.

Perches having a potential of 0.25 million t against the exploited level of 66,000 t are the other important demersal resources. The 'Kalava' resource of the southwest coast, the resident and migrant perches of Wadge Bank, the threadfin bream resource in the 75-225 m depth range occurring in concentration during February-May and July-September along the southwest and upper east coasts are the major perch resources to be harvested.

The sciaenids of which the current yield is 0.11 million t show a potential of 0.21 million t. Rich grounds exist in the northwest and east coasts at a depth of 50-200 m. Likewise elasmobranchs with a current yield of 60,000 t indicate a potential of 0.18 million t. Good grounds are located in the lower east coast (100-200 m depth) and north-west coast upto 100 m depth.

Deep sea non conventional resources including potential stocks of the bulls eye, indian drift fish, black ruff, rat tails, boar fishes and miscellaneous varieties of deep sea fishes from the continental slope (220-500 m depth) are indicated from the southwest and east coasts.

Crustacean resources

Very little scope exists for increasing production of penaeid prawns from the traditional shrimp grounds. However, the non-penaeid prawns with a current yield of 59,000 t show a potential of 0.11 million t. Similarly the deep water shrimp and lobster with only the nominal yield of 500 t at present, indicate a potential of 12,000 t.

The sustainable potential of deep water prawns along the southwest coast is estimated at 3,000t. For deep water lobster, the estimate is 8,000t off the southwest coast and over 1,000 t off the lower east coast. The maximum abundance of deep sea prawns was observed in 300-400m depth during February-June. For exploitation of deep sea prawns and lobsters in the shelf and slope regions on the southwest coast and Gulf of Mannar, larger trawlers will have to be used.

Cephalopod resources

Cephalopods consisting of squids, cuttle fishes and octopii are caught at present mostly from the west coast. The cephalopod resources are now obtained from general trawl operations. The additional resources of about 50,000t are expected from the areas beyond 50 m depth zone if direct method like squid jigging is introduced. Considerable potential of oceanic squids is also indicated.

Seasons of commercial availability

It is difficult to sharply demarcate any season of commercial availability of the different resources in the tropical waters. However, the general seasonal pattern of availability of the target species in different regions as seen from the published literature is indicated here. For the sake of convenience, the year is divided into three seasons: namely premonsoon (February to May), monsoon (June to September) and postmonsoon (October to January).

In the northwest region availability of catfishes, perches, ribbonfishes and cephalopods are found to be more in pre and postmonsoon seasons and croakers, coastal tunas and crustaceans in monsoon and postmonsoon seasons.

In the southwest coast, perches, ribbonfishes, carangids, crustaceans and cephalopods are the important resources in the monsoon and postmonsoon seasons, croakers and coastal tunas in pre and postmonsoon seasons, perches and elasmobranchs in pre-

monsoon and monsoon seasons and whitebaits in postmonsoon season.

In the lower east coast, the better seasons for fishing for croakers, coastal tunas, elasmobranchs, crustaceans and cephalopods have been found to be pre and postmonsoon, the monsoon season for whitebaits and ribbon fishes and the premonsoon season for catfishes.

The season of commercial availability in the upper east coast for catfishes, coastal tunas, carangids and perches has been found to be pre and postmonsoon seasons, the monsoon and postmonsoon seasons for croakers, ribbonfishes, elasmobranchs, crustaceans and cephalopods and the postmonsoon for whitebaits. Regarding deep sea prawns better catch rates were observed during June to September along east coast and September to February along the west coast.

EXISTING INFRASTRUCTURE FOR EXPLOITATION OF OFFSHORE RESOURCES

Vessels and gear

It was estimated that at the end of 1985 the following number of fishing vessels were operating in the offshore/deep sea areas around the Indian sub-continent.

14-18 m OAL vessels (Medium) : 28

18-40 m OAL vessels (Large) : 154

Most of the medium vessels were used for exploratory fishing and were operated by the FSI. Of the 154 large vessels, 50 were on charter from foreign agencies and were operated near Andaman and Nicobar Islands. Except for a few vessels which belonged to FSI, CIFNET and IFP of the Govt. of India, all the vessels below 30 m OAL were commercial shrimp trawlers. Vessels above 30 m OAL were mainly used for mid-water trawling, purse-seining and long lining.

TABLE - 3

Details of Fishery Survey Vessels operated by FSI

Name of vessel	OAL	BHP	GRT	Type of fishing conducted
Matsya Shakthi	36.5	825	327.18	Trawling
Matsya Vishwa	36.5	825	327.18	Trawling
Matsya Sugandhi	31.5	650	248.45	Tuna long lining & squid jigging
Matsya Varshini	36.5	1160	268.33	Purse-seining & trawling
Matsya Vigyani	32.21	750	257.95	Trawling
Matsya Nireekshani	40.5	2030	329.36	"
Matsya Jeevan	36.5	825	327.18	"
Matsya Harini	32.5	750	257.95	Purse-seining
Matsya Shikari	39.5	1740	352.47	Trawling
Matsya Darshini	36.5	1740	352.47	Purse-seining & trawling
Meena Anveshak	17.5	200	57	Trawling
Meena Gaveshak	17.5	"	"	"
Meena Netra	17.5	"	"	"
Meena Sitara	17.5	200	57	"
Meena Tharangini	17.5	200	57	"
Meena Pradata	17.5	200	57	"
Meena Ayojak	17.5	200	57	"
Meena Prapi	17.5	200	57	"
Meena Saudagar	17.5	200	57	"

TABLE - 4
Details of large vessels of IFP

Name of the Vessel	OAL (m)	BHP	GRT	Type of fishing in which engaged
Samudra Devi	27.31	750	193.86	Bottom/Pelagic trawling & Purse seining
Velameen	23.85	480	117.21	Bottom/pelagic trawling
Tuna	23.80	480	115.62	-do-
Klaus sunnana	19.81	220	61.28	-do-
Norind - II	13.17	72.5	19.27	Bottom/pelagic trawling and purse seining

TABLE - 5
Details of vessels of CIFNET

Name of vessel	OAL (m)	BHP	GRT	Type of fishing
Prashikshani	34.0	750	211.29	Tuna long-lining, trawling
Skipper-I	33.51	750	268.39	Long lining, purse seining, traps
Skipper-II	28.30	600	174.82	Trawling
Skipper-III	28.30	600	174.82	Trawling
Blue Fin	28.35	600	181.88	..
Red Snapper	28.35	600	181.88	..
Master Fisherman	17.5	200	57.0	..
Master Fisherman-I	17.5	200	57.0	..
Master Fisherman-II	17.5	200	57.0	..
Master Fisherman-III	12.27	93	22.0	Gill netting, trawling

However, the vessels on charter and the existing shrimp trawlers would not contribute much to the supply of fin fish to the domestic market in particular because the chartered vessels land their catches at foreign ports and the existing shrimp trawlers do not bring fish other than shrimp to the shore partly due to the sales obligations and partly due to the scarcity of storing space onboard.

The details of vessels and types of fishing conducted by the Govt. of India vessels attached to FSI, IFP and CIFNET are given in Table 3, 4 and 5.

Landing and berthing facilities

The details regarding fishery harbours completed/under construction located in the various states are given in Table-6 (Anon.,

1983). A total of 15 harbours located at Veraval, New Ferry wharf, Ratnagiri, Marma Goa, Karwar, Malpe, Cochin, Vizhinjam, Tuticorin, Madras, Kakinada, Visakhapatnam, Paradeep, Dhamra and Roychowk already constructed/under construction have a designed capacity for berthing about 500 deep sea/offshore fishing vessels. However facilities for unloading of catches, supply of fresh water, fuel, ice and repair facilities for craft and gear are inadequate at most of the above mentioned harbours.

EXISTING PATTERN OF UTILIZATION

Fresh fish

In India about 2/3 of the total marine fish catch is being consumed in fresh

TABLE - 6
*Fisheries Harbours completed/under construction
 with their designed vessel capacity
 (Source : BOBP/INF/3)*

Region	Name of Port	Designed Capacity	
		Deep sea vessels	Mechanised boats
	<i>Gujarat</i>		
	Veraval	20	300
	Mangrol	—	210
	Porbander	—	140
NW Coast	Jaffrabad	—	32
	Vansi Porsi	—	45
	Kosamba	—	425
	<i>Maharashtra</i>		
	New Ferry Warf	N. A.	N. A.
	Sassoon Dock	—	700
	Ratnagiri	40	400
	Karanja	—	30
	<i>Karnataka</i>		
	Malpe	20	300
	Honavar	—	120
	Karwar	20	200
	Mangalore	—	230
SW Coast	<i>Kerala</i>		
	Cochin	57	450
	Sakthikulangara	—	500
	Vizhinjam	85	210
	Valiapatnam	—	54
	Mapila Bay	—	166
	Kasargod	—	100
LE Coast	<i>Tamil Nadu</i>		
	Tuticorin	65	300
	Madras	50	500
	Mallipatnam	—	54
	Kodiekkarai	—	54
	Cudallore	—	54
UE Coast	<i>Andhra Pradesh</i>		
	Visakhapatnam	50	300
	Kakinada	15	200
	Bavanappadu	—	200
	Nizampatnam	—	100
	<i>Orissa</i>		
	Paradeep	N.A.	N.A.
	Dhamra	15	35
	Chandipur	—	28
	<i>West Bengal</i>		
	Roychauk	15	—
	<i>Andaman & Nicobar islands</i>		
	Phoenix Bay	—	47

NA: Information not available

condition (Nair and Govindan, 1986). However the per capita consumption of fish declines considerably as the distance increases from the landing centre. Among the states the per capita consumption of fresh marine fish is the highest in Goa (37.26kg). It is the lowest in W. Bengal and Gujarat where only 1.07 and 1.47 kg respectively are consumed (Girija and Ravinath, 1986).

Frozen fish

Freezing as a means of fish preservation was first introduced in the country in the 1950s. Currently a little more than 5% of the total marine fish catch is being used for freezing purposes. The method is now mainly employed for export commodities like prawns, lobsters, squids and cuttle fishes of which the prawns rank first. A quantity of 49,540 t of frozen prawns were exported in 1985 and this works out to 74.51% of the total frozen sea food exported. With regard to fishes, a quantity of 9,557 t were frozen and exported in 1985 which accounted for 14.3% of the total frozen marine products exported.

Canned fish

In the 1960s and early part of the next decade shrimp canning and export was very popular in India. The record export of 2,199 t of canned shrimp was registered in 1973. Thereafter the exports dwindled down to a mere 15 tonnes in 1985. Fishes like sardines, mackerel and tuna were canned mainly for internal use. The set back to the industry has been caused by the increase in the cost of imported containers and edible oil. Alternative means of canning have been tested and found economical but the industry is rather slow in adopting these methods.

Cured and dried fish

The second largest method of utilization of fish in India is by salt curing and drying and this accounts for about 20% of the total fish landings. The traditional export markets for cured fish like Sri Lanka and Burma have dwindled in recent times. Being the easiest and the cheapest method of fish preservation it is bound to remain for quite a long time. In 1985 a total of 9,022 t cured/dried fishes were exported.

Fish marketing

As far as fish is concerned its marketing is as important as fishing itself. Fish has to reach the end user in the minimum possible time especially when it is marketed in fresh condition. Fish either in fresh or processed form has to go through several hands before it reaches the consumer. Thus fish marketing has several components like handling, transport, processing and storage. Intermediaries which consist of auctioners, commission agents, wholesalers, retailers and vendors also play important roles in marketing.

In India, fish is marketed as fresh fish, frozen fish, dry edible fish and fish meal. Regarding the physical flow of fish it is seen that in majority of cases, about 50% of the fresh fish marketed is consumed in nearby areas of the landing centres, about 45% within a distance of 200 km and the rest in places beyond 200 km. However, this may vary from state to state.

While the percentage of marine fish consumption is 62 in Maharashtra the same is only 2 in West Bengal. While Karnataka and Gujarat stand at top regarding exporting the fish to other states, Maharashtra and Tamil Nadu are the largest importers.

When the fresh fish flow from the production centre is taken into consideration, Veraval and Porbandar in Gujarat, Bombay in Maharashtra, Manglore in Karnataka, Cannanore and Cochin in Kerala, Madras in Tamil Nadu, Kakinada and Visakhapatnam in Andhra Pradesh, Paradeep and Chandipur in Orissa are the largest exporters to other centres within and outside the states.

As far as dry edible fish is concerned, Maharashtra, Gujarat, Karnataka and Andhra Pradesh contribute mostly to the inter-state movement. The maximum consumers of dry edible fish are in the non-coastal areas especially in the north-eastern states. In the major dry fish selling states the important centres that send out this commodity are Veraval and Porbander in Gujarat, Bombay and Poona in Maharashtra, Mangalore in Karnataka and Kakinada, Machilipatnam and Nizamapattanam in Andhra Pradesh.

More than 97% of domestic fish marketing and 93% of dry edible fish marketing are considered to have been handled by private trade. The co-operatives have very small share. The fishermen's co-operative societies as in Maharashtra take the fish directly to the consumers thereby ensuring maximum profit to the fishermen. Eventhough many of the maritime states have fisheries corporations of some form or other, they are not effectively involved in fish marketing.

PROJECTION FOR ADDITIONAL EXPLOITATION

Vessel requirement

On the basis of data on potential resources and assumptions on possible catches by introducing suitable vessels and fishing methods, projections for the different resources are made. The plan is to harvest about 15-60% of the selected additional resources in a phased manner over a period of five years. Thus for the first year of implementation the strategy suggested is to harvest 0.11 million t of fish including white baits, coastal tunas, carangids, ribbon fishes, catfishes, perches, croakers, elasmobranchs, crustaceans and cephalopods (Table 7). This figure excludes the likely catches of oceanic tunas and cephalopods.

Table 8 gives the proposed additional number of vessels for a one year period. It is seen that to harvest the indicated 0.11 million t of fish in one year total of 160 vessels consisting of 65 numbers of 13.6 m wooden purse-seine vessels, 55 numbers of 17.5 m steel trawlers (mid-water/bottom) and 40 numbers of 26 m steel trawlers are to be deployed. The capital investment for the purse-seines would be Rs. 65 million, medium steel trawlers Rs.182 million and larger steel trawlers Rs. 400 million thus totalling to Rs. 647 million.

Each type of vessel will operate for the different resources for 200 days in an year. The region-wise distribution of the different types of vessels is given in Table 8.

Trained manpower requirement

The requirement of trained manpower for the different categories of vessels has been

TABLE - 7

Expected additional catch (t) for a one year period

Region	N.W.	S.W.	L.E.	U.E.	Total
Resource					
White baits	—	8820	10500	1680	21000
Coastal tuna	2535	5080	830	555	9000
Eiasmobranchs	1375	420	1410	345	3550
Catfish	2770	3855	800	1435	8860
Perches	2500	4675	2475	1830	11480
Croakers	3800	1130	1230	700	6860
Ribbonfish	3410	2010	1180	1330	7930
Carangids	1605	2030	1915	2250	7800
Crustaceans	320	640	160	480	1600
Cephalopods	2750	1250	710	210	4920
Trawl by-catches	9435	6630	5610	3825	25500
Total	30500	36540	26820	14640	108500

TABLE - 8

Proposed additional number of vessels for one year period

Region	NW	SW	LE	UE	Total
Type of vessel					
1. Purse seiner (wooden) (13.5 m OAL)					
a) White-baits-100 days at 3t/day	—	17	20	3	40
b) Coastal tuna 100 days (1t/day)					
2. Purse seiner (Wooden 13.6 m OAL)	7	14	2	2	25
Coastal tunas 200 days (1 t/day)					
3. Trawler (17.5 m OAL)					
a) White baits-100 days by mid-water trawling (2t/day)	—	19	22	4	45
mid-water trawling (2t/day)					
b) Catfish, ribbonfish, carangids and others					
— 100 days by mid-water/bottom trawling (2t/day)					
4. Trawler (17.5 m OAL) Catfish, ribbonfish,					
carangids and others	10	—	—	—	10
— Mid-water/bottom trawling — 200 days (2 t/day)					
5. Trawler (26 m OAL) Fish/crustacean	15	10	9	6	40
— 200 days					
— bottom trawling (5 t/day)					
Total	32	60	53	15	160

Note: Trawl by catch at $\frac{1}{2}$ t/day for 200 days by 17.5 m vessels and $2\frac{1}{2}$ t/day for 200 days by 26m vessels.

TABLE - 9

Requirement of trained personnel per vessel and for total no. of vessels for a one year period (Totals in brackets)

Category of posts	No. of personnel required			Total
	13.6 m purse * seines (65 units)	17.5 Trawler (55 units)	26 m Trawler (40 units)	
Skipper	—	1 (55)	1 (40)	2 (95)
Chief engineer	—	—	1 (40)	1 (40)
Mate	—	—	1 (40)	1 (40)
Bosun	1 (65)	2 (110)	2 (80)	5 (255)
Engine Driver	1 (65)	1 (55)	1 (40)	3 (160)
Engiee room Asst.	—	1 (55)	1 (40)	2 (95)
Fishing hands	6 (390)	5 (275)	10 (400)	(21) (1065)
Cook	1 (65)	1 (55)	2 (80)	4 (200)
Total	9 (585)	11 (605)	19 (760)	39 (1950)

*In the present type of purse seining where there is very little or no mechanisation involved in pursing and heaving the net a larger compliment of about 25 deck crew is required.

considered based on the existing practices and regulations. It is estimated that a total of 1950 trained personnel including 85 skippers and 40 chief engineers are required for a one year period. Details of all the categories required are given in Table 9.

Economics of vessel operations

The economics of operations of the different types of vessels are worked out on the basis of prevailing cost of vessel, operational costs as well as productivity and market prices.

For the 13.6 m wooden purse-seiner operating for whitebaits for 100 days and tunas for another 100 days, a net return of Rs. 0.22 million per annum against a capital cost of

Rs. 1.0 million for the vessel and gear is arrived at (Table 10). The assumptions are: a catch of 300 t of whitebaits at the rate of 3 t/day for 100 days to be sold at Rs. 2.50/kg and a catch of 100 t of small tunas at the rate of 1 t/day for 100 days sold at Rs. 5/kg. The net profit is computed after deducting fixed and operational costs including crew share (before taxation). From the second type of operation of the 13.6 m vessel, exclusively conducting small tuna purse-seining for 200 days of the year, a net return of Rs. 0.14 million is arrived at the assumption being production of 200 t of fish in a year at the rate of 1 t/day for 200 days, sold at Rs. 5/kg (Table 11).

TABLE - 10

Projected economics of operation of a 13.6 m OAL (wooden) purse-seiner for whitebaits

1. Capital Investment (Rs.)					
1.1	Investment on craft + dinghy				7,00,000
1.2	Investment on gear				3,00,000
1.3	Total				<u>10,00,000</u>
2. Fixed cost (Rs.)					
2.1	Depreciation @ 8.5% on vessel				59,500
2.2	Depreciation @ 50% on gear				1,50,000
2.3	Interest on capital @ 15% p. a.				1,50,000
2.4	Total fixed cost				<u>3,59,500</u>
3. Operational cost (Rs.)					
3.1	Fuel oil lubricants				
3.1.1.	@ 20 l/hr, 10 hrs. of running per day of fishing (main engine and auxiliary) @ Rs. 4.50/l for 200 days				1,80,000
3.1.2.	Auxiliary engine (5%) of above				9,000
3.1.3.	Lubricants				6,000
3.2.1.	Repairs and maintenance of vessel + dinghy				20,000
3.2.2.	" " " gear				10,000
3.3.	Crew share (12,50,000 minus for purse seiner 2,49,000 (variable cost x 33% -				3,30,330
3.4	Quantum set apart for obtaining the services of carrier boats @ 15% of revenue realised out of white-bait catches minus 50% of the total variable cost			(7,50,000 minus 1,24,500) x 15% = 93,825	
3.5	Expenditure for shore facility				6,000
3.6	Unloading of fish catches at the jetty				6,000
3.7	Cost of ice etc.				6,000
3.8	Miscellaneous				6,000
3.9	Total operational cost				<u>6,73,155</u>
4. Total cost (Rs.)					
					10,32,655
5. Revenue from fish catches (Rs.)					
5.1	Whitebaits purse seining 100 days @ 3 t/day of fishing x Rs. 2500/t				7,50,000
5.2	Tuna purse seining for remaining 100 days @ 1 t/day of fishing x Rs. 5000/t				5,00,000
5.3	Total revenue				12,50,000
6. Net earning (Rs.)					
					2,17,345
7. Economic parameters					
<i>Rate of returns %</i>	<i>Pay back period (years)</i>	<i>Fixed cost-gross returns ratio %</i>	<i>Operational cost-gross return ratio %</i>	<i>Fuel cost gross return ratio (%)</i>	<i>Break even catch level/annum</i>
37	2.4	29	54	16	210 t of white-baits & 70 t of tuna

TABLE - 11

Projected economics of operation of a 13.6 m OAL (wooden purse-seiner for tuna)

1. Capital Investment (Rs.)		
1.1	Investment on craft + dinghy	7,00,000
1.2	Investment on gear	3,00,000
		10,00,000
2. Fixed cost (Rs.)		
2.1.	Depreciation @ 8.5 % on vessel	59,500
2.2.	Depreciation @ 50% on gear	1,50,000
2.3.	Interest on capital @ 15% p. a.	1,50,000
		3,59,500
3. Operational cost (Rs.)		
3.1. Fuel oil and lubricants		
3.1.1.	@ 20 l/hr. 10 hrs. of running per day of fishing (main engine and auxiliary) — Rs. 4.50/l for 200 days	1,80,000
3.1.2.	Auxiliary engine (5%) of above	9,000
3.2.3.	Lubricants	6,000
3.2.	Repairs and maintenance of vessel + dinghy	20,000
3.3.	“ “ “ gear	10,000
3.4.	Crew share : 10,00,000 minus 2,49,000 (variable cost) x 33% =	2,47,830
3.5	Expenditure for shore management	6,000
3.6.	Unloading of fish catches at the jetty	6,000
3.7	Cost of ice etc.	6,000
3.8	Miscellaneous	6,000
3.9	Total operational cost	4,96,830
4. Total cost (Rs.)		8,56,330
5. Revenue from fish catches (Rs.)		
	Operating 200 days @ 1 t/day of fishing x Rs. 5000/t	10,00,000
6. Net earning (Rs.)		1,43,670

7. Economic parameters

Rate of returns %	Pay back period (years)	Fixed cost gross returns ratio (%)	Operational cost-gross returns ratio (%)	Fuel cost-gross return ratio (%)	Break even catch/ annum
29	2.8	36	50	20	156 t of tuna

For the 17.5 m steel trawler the capital investment estimated is Rs. 3.3 million. These vessels engaged in mid water and bottom trawling for 200 days a year are expected to obtain a catch rate 2 t a day of target fish and $\frac{1}{2}$ t by-catch. A flat rate of Rs. 6/kg has been assumed for the main catch and Rs. 2/kg for the by-catch. The net profit is estimated

to be Rs. 0.91 million for each vessel (Table 12).

With regard to the operation of 26 m steel trawler, the capital cost for vessel and gear is taken to be Rs. 10.0 million (Table 13). The revenue computed for this vessel is on the basis of a catch at the rate of 5 t/day for 200 days comprising mixed quality fishes

TABLE - 12

Projected economics of operational of a 17.5 m OAL Steel trawler

1. Capital investment (Rs.)						
1.1	Investment on craft					30,00,000
1.2	Investment on gear					3,00,000
1.3	Total					<u>33,00,000</u>
2. Fixed cost (Rs.)						
2.1	Depreciation — 8.5% on vessel					2,55,000
2.2	Depreciation — 50% on gear					1,50,000
2.3	Interest on capital @ 15% p. a.					4,95,000
2.4	Total fixed cost					<u>9,00,000</u>
3. Operational cost (Rs.)						
3.1 Fuel oil and lubricants						
3.1.1	@ 40 l/hr. 10 hrs of running per day of fishing (Main & Aux.) @ Rs. 4.50/l for 200 days					3,60,000
3.1.2	Auxiliary engine 5% of above					18,000
3.1.3	Lubricants					18,000
3.2	Repairs and maintenance of the vessel					1,00,000
3.3	Repairs and maintenance of gear					40,000
3.4	Salary of crew					2,00,000
3.5	Expenditure for shore management					10,000
3.6	Incentive to crew					25,000
3.7	Unloading at jetty, cost of ice etc.					12,000
3.8	Miscellaneous					6,000
3.9	Total operational cost					<u>7,89,000</u>
4.	Total cost (Rs)					16,89,000
5. Revenue from fish catch (Rs)						
	400 t @ Rs. 6,000/t for main catch and 100 t @ Rs. 2,000/t for by-catch					26,00,000
6.	Net earning (Rs.)					9,11,000
7. Economic parameters						
<i>Rate of returns</i>	<i>Pay back period</i>	<i>Fixed cost-gross return ratio</i>	<i>Operational cost-gross return ratio (%)</i>	<i>Fuel cost-gross returns ratio (%)</i>	<i>Break even catch annual</i>	
%	(years)	%				
43	2.5	35	30	15	260 t of main catch & 65 t of by-catch	

like carangids, perches, cat fishes, croakers and crustaceans and 2½ t/day of by-catch. The price indicated for the catch is a flat rate of Rs. 6/kg for the main catch and Rs. 2/kg for by-catch. The net profit arrived at is Rs. 2.1 million.

Some of the economic parameters relating to the operation of the four types of vessels have been estimated and the values are given in item 7 of the Tables 10 to 13. As seen from the tables, the rate of return, in all the four

TABLE 13

Projected economics of operation of a 26 m OAL steel trawler

<i>Capital Investment (Rs.)</i>					
1.1	Investment on craft				95,00,000
1.2	Investment on gear				5,00,000
1.3	Total				<u>100,00,000</u>
<i>2. Fixed cost (Rs.)</i>					
2.1	Depreciation @ 8.5% on vessel				8,07,600
2.2	" @ 50% on gear				2,50,000
2.3	Interest on capital @ 15%				15,00,000
2.4	Total fixed cost				<u>25,57,600</u>
<i>3. Operational cost (Rs.)</i>					
3.1	Fuel oil and lubricants				
3.1.1	@ 75 l/hr 20 hrs. of running/day of fishing (Main & Aux.) @ Rs. 4.50/l for 200 days				13,50,000
3.1.2	4 hrs/day for Aux. for 200 days @ 10 l/hr @ Rs. 4.50				36,000
3.1.3	115 days on shore at jetty-Auxiliary engine 8 hrs/day @ 10 l/hr @ Rs. 4.50				41,400
3.1.4	Lubricants and refrigerants				1,00,000
3.2	Repairs and maintenance of vessel				2,50,000
3.3	Repairs and maintenance of fish gear and fabrication of new gear				1,00,000
3.4	Salary of officers and crew				3,00,000
3.5	Expenditure for shore management				30,000
3.6	incentives and allowance to crew				70,000
3.7	Unloading of fish catches at jetty				35,000
3.8	Miscellaneous				35,000
3.9	Total operational cost				23,47,400
4.	Total cost (Rs.)				49,04,900
5.	Revenue (Rs.) from fish catches				
	1,000 t @ Rs. 6,000/t for main catch and 500 t @ Rs. 2,000/t for by-catch				70,00,000
6.	Net earning (Rs.)				<u>20,95,000</u>
<i>7. Economic parameters</i>					
<i>Rate of returns of %</i>	<i>Pay back period (years)</i>	<i>Fixed cost-gross returns ratio (%)</i>	<i>Operational cost-gross returns ratio (%)</i>	<i>Fuel cost-gross returns %</i>	<i>Break even catch annum</i>
36	3.2	37	34	20	700 t of main catch & 350 t of by-catch

types is quite high to indicate economic viability in their operations under the stated conditions. The operational cost-gross returns ratio is much higher for purse-seiners. This is mainly because of the higher proportion of the revenue which goes as the total wage amount in purse-seiners as compared to trawlers

The project economics of operation for a 34 m steel tuna long-liner is shown in Table 14. Wide variation in the hooking rate as well as for unit price have been reported. Assuming a price of Rs. 10,000/t for tuna and Rs. 5,000/t for by-catches the break-even level of production has been worked out as 540 t of tuna per annum.

TABLE - 14
Projected economics of operation of a 34 m OAL tuna long-liner (steel)

1. Capital cost (Rs.)	
1.1 Vessel	1,20,00,000
1.2 Long line gear (300 baskets with 5 hooks each)	3,00,000
1.3 Total	<u>1,23,00,000</u>
2. Fixed cost (Rs.)	
2.1 Depreciation @ 8.5 on vessel	10,20,000
2.2 Depreciation @ 50% on gear	1,50,000
2.3 Interest on capital @ 15 %	18,45,000
2.4 Total fixed cost	<u>30,15,000</u>
3. Operational cost (Rs.)	
3.1 Fuel oil and lubricants	16,15,000
3.2 Cost of bait fish 150kg/day x 15 day x 15 days'trip x 11 months x Rs. 4/kg.	99,000
3.3 Crew salary	3,10,000
3.4 Incentive to crew	3,03,527
3.5 Stores and incidentals (12,000 x 12)	1,44,000
3.6 Repairs (2000 x 12)	24,000
3.7 Berthing and other port charges (5,000 x 12)	60,000
3.8 Annual drydocking	5,00,000
3.9 Total operational cost	<u>30,55,527</u>
4. Total cost (Rs.)	
*5. Break even catch level and returns	
5.1 Value (Rs.) of break even catch level of 540 t (539.60 t correct to 2 decimals) of tuna per annum (20 days) of actual fishing per month and 10 months operation) @ Rs. 10,000/t	53,96,024
5.2 Value (Rs.) of by catches (one fourth of by catches (one fourth of tuna catches) @ Rs. 5,000/t	6,74,503
5.3 Total revenue (Rs.)	<u>60,70,527</u>
6. Net returns (Rs.)	Nil

* As the catch rates and unit prices cited in literature are highly varying, only the breakeven catch level at the price of Rs. 10,000 t is considered in the above tables. However, profits for various combinations of catch levels and unit prices have been calculated and the same are presented in Table.

Exploitation of oceanic resources

Tunas: Under this category the oceanic tuna resources are of prime importance. In this regard the suggestions given in this paper are purely indicative.

Silas and Pillai (1985) have made certain time bound projections on the possible development of commercial tuna production. They envisaged a target of achieving 20,000 t of large oceanic tunas by long lining by 1990. Recently the exploratory long lining conducted by the Central Institute of Fisheries Nautical Engineering and Training northwest of Mangalore within the EEZ has demonstrated the commercial availability of yellow fin tunas in these areas (Swaminath *et al.*, 1986). The results of tunas long lining by Fishery Survey of India vessel 'Matsyugandhi' also revealed

very rich tuna grounds in the same area (Joseph and John, 1986).

However, private or public sector entrepreneurship have not so far seriously attempted commercial exploitation of these resources and as such no progress has yet been made in exploiting oceanic tunas.

Long lining and purse-seining of oceanic tunas are being carried out successfully in the western Indian Ocean mainly by France, Spain, South Korea and Japan by obtaining licences for fishing in the EEZ of Seychelles, Somalia and Mozambic.

In this context, immediate option for India for the exploitation of large oceanic tunas in the EEZ is to organise operation by a small tuna long lining fleet. The feasibility of commercial purse seining also should be explored.

TABLE - 15

Expected profit ('000 Rs/annum) in tuna long-liner (34 m) operations for different levels of catch and unit prices

Catch level of tuna (t/annum)	Price of tuna ('000 Rs. per t)						
	10	15	20	25	30	35	40
150	-4164	-3451	-2739	-2026	-1314	-601	111
200	-3629	-2679	-1729	-779	171	1121	2071
250	-3095	-1908	-720	467	1655	2842	4030
300	-2561	-1136	289	1714	3139	4564	5989
350	-2026	-364	1299	2961	4624	6286	7949
400	-1492	408	2308	4208	6108	8008	9908
450	-958	1180	3317	5455	7592	9730	11867
500	-423	1952	4327	6702	9077	11452	13827
550	111	2724	5336	7949	10561	13174	15786
600	646	3496	6346	9193	12046	14896	17746
650	1180	4267	7355	10442	13530	16617	19705
700	1714	5039	8364	11689	15014	18339	21664
750	2249	5811	9374	12936	16499	20061	23624
800	2783	6583	10383	14183	17983	21783	25583
850	3317	7355	11392	15430	19467	23505	27542
900	3852	8127	12402	16677	20952	25227	29502
950	4386	8899	13411	17924	22436	26949	31461
1000	4921	9671	14421	19171	23921	28671	33421
Break even catch level (t annum)	540	374	286	231	194	167	147

However, in both cases joint venture/chartering arrangements and availing foreign expertise from countries like Japan will be required for successful commercial implementation of these programmes by India.

The main fishing unit proposed for exploitation of oceanic tunas is the 34 m steel tuna long liner. The vessel and gear are estimated to cost Rs. 12.3 million (Table 14). As the catch rates and unit prices cited for tuna long line fishing are highly varying, it is felt useful to provide a table of profit values for a wide range of catch level and unit price. The estimated profits for different combinations are given in Table 15. In the calculation, value of by-catches has also been included on the revenue side.

As seen from the table, if the price of a kg of tuna is Rs. 20/kg, at the landing centre, more than 286 tonnes of tuna should be caught per annum for profit, while if the price is Rs. 10/kg, more than 540 tonnes should be caught per annum for profit. Other combination can be read out from the table. The tabular information helps in arriving at the number of long-liners required for economically exploiting a specified quantity of the resource.

Cephalopods: George *et al.* (1977) indicated a potential yield of 0.18 million t of cephalopods from the Indian EEZ.

Silas (Ed. 1985) emphasises the urgent need for developing directed fishing for cephalopods from our continental shelf waters and suggests utilization of some of the mechanised boats (9-13 m) for light fishing with lift nets. It is also suggested that the traditional gears for specific capture of squids and cuttlefishes are upgraded and use of traps and posts for *Octopus* in the reef and lagoon areas encouraged. The multi-species trawl fishery of the inshore shelf bring in cephalopods in various proportions and the utilisation of these catches is to be improved.

The Taiwanese bull trawlers which fished on charter arrangements along the northwest coast of India in the early eighties confirmed the existence of excellent squid and cuttlefish grounds in this area.

From 15.80 t in 1982, the cephalopod catches have registered a rise to 42.64 t in 1986 indicating the increased effort and returns in this fishery. This catch has overshoot the 30,000 t of potential harvest projected by Silas (Ed, 1986) for the year 1990.

Chikuni's (1984) estimate of potential yield of neritic cephalopods from the Bay of Bengal is of the order of 50-100 thousand t and from the Eastern Arabian Sea 100-150 thousand t. In this context it is essential that concrete steps are taken to harvest much more of this under exploited resource of our neritic and oceanic waters.

In addition to strengthening the efforts in harvesting cephalopods from the neritic waters pioneering efforts are to be made in target fishing for some of the known commercial oceanic species of cephalopods. Among them are to be mentioned the Indo-Pacific species *Symplectoteuthis oulaniensis* apparently restricted to the northern and central parts of the Indian Ocean.

'Shoyo Maru' surveys (Fishery Agency, 1976 to 1979) located significant stocks of *S. oulaniensis* in north Arabian sea. The species, however, is not at present known to be commercially exploited in any part of the Indian Ocean.

Jigging, light fishing and drift gill net fishing are the appropriate techniques for exploitation of cephalopod resources of EEZ for which expertise are to be drawn preferably from Japan through joint venture or charter arrangements.

Due to lack of precise information on items such as productivity, distribution and economics no specific projections are made regarding the number of squid-jiggers and other vessels required. A series of simulated commercial fishing would help in generating the required data base. A programme is already under way to test the technical feasibility and economic viability of squid jigging in the Indian waters under the auspices of CIFNET, FSI and CMFRI and the results are awaited.

PROJECTIONS FOR ADDITIONAL REQUIREMENT OF INFRASTRUCTURE FACILITIES

For the exploitation of the projected potential of resources from the existing grounds as well as from the rest of the EEZ apart from suitable crafts and gears, several infrastructure facilities like harbours, ice and freezing plants, curing and drying plants, fish meal plants, and adequate facilities for transportation are required and the following is a discussion on the same.

Landing and berthing facilities

An examination of the existing facilities for landing and berthing the mechanised boats and deep sea fishing vessels indicates that the capacity of the harbours and jetties currently available cannot meet any future demand. The designed berthing capacity of the major and minor ports completed / under construction (Table 6) is for about 500 deep sea vessels (Anon., 1983). If all the facilities at the ports are established as originally envisaged this would cater to the needs of existing as well as additional vessels proposed for the first year. However proportionate expansions of harbour facilities will be required to accommodate progressive introduction of boats during subsequent years. Therefore it is suggested that action may be taken to build up the full capacities and expand all the infrastructural facilities at selected centres.

Requirement of ice

Ice is being used irrespective of the fact whether the fish is consumed fresh in nearby places or at distant places or even exported. At present a total production capacity of 2,000 t of ice per day exists in the country, established in different regions; 480 t UE coast, 335 t LE coast, 885 t SW coast and 330 t NW coast (Anon., 1983). Several estimates of requirement of ice have been made which according to various uses may vary from 0.75 to 1.25 kg per kg of fish. Taking a figure of 1 kg of ice per kg of fish, the total requirement for projected additionally exploited resource of 0.11 million t would be 0.11 million t of ice a year. Thus at the end of the 5th year, production of 0.55 million t

of ice per year would have to be effected to meet the requirements of the additional production. The additional ice plants to meet the requirements are proposed to be established at 9 major centres, namely Veraval, Bombay, Malpe, Cochin, Tuticorin, Madras, Visakhapatnam, Paradeep and Roychowk. The number and capacity of the plants at each centre would depend on the landings for which guidelines can be drawn from the distribution of expected landing figures (Table 7).

Cold storage

Cold storages are used for storing ice, storing fresh fish and for storing frozen fish. As on April, 1985 there were 272 freezing plants and 308 cold storages with the total storage capacity of 34,300 t of fish and a daily freezing capacity of 1,900 t (Bhaduri, 1985). The region-wise availability of freezing plants and cold storages is given in Table 16. However, at present most of the cold storages are not functioning or are being used for storing ice due to lack of demand for fish storage. There are some large cold storages where 95% of the space is used for other than fishery purposes. In this context, immediate expansion of cold storage capacity is not envisaged.

TABLE - 16

Freezing plants and cold storages in India

Region	Freezing plants	Cold storages
U. E. Coast	73	62
L. E. Coast	27	36
S. W. Coast	114	148
N. W. Coast	58	62
Total	272	308

Source : Fishing Chimes Oct., 1986.

Curing and drying facilities

At present most of the curing and drying of fish are being done in open air conditions. This calls for the establishment of modern facilities for these purposes. Curing and drying being the second largest method of fish utilization in the country, elaborate infrastructure facilities are required to be

established and hence the same could be taken up as a phased programme in the years to come. At present about 20% of the total marine fish catch (about 0.3 million t) goes for curing and drying (Nair and Govindan, 1986). Assuming that the same ratio will hold for projected additional production of 0.11 million t fish a year, modern facilities for drying 0.022 million t of fish are to be immediately established at the major and minor fish landing centres, where these catches are expected to be landed. In view of the large quantities of *Stolephorus* spp. which are expected to be landed along the lower east coast, a major facility may be established at Tuticorin and near about centres. To start with plants of appropriate capacities as per CIFT specifications may be established at the major and minor fisheries harbours.

Fish meal plants and fish pulverizers

The capacity of fish meal plants in the country (Gupta et al., 1984) has been estimated as 374 t per day and that of the fish pulverizers to be 925 t per day (in terms of fresh weight). The total production capacity of fish meal plants and pulverizers was about 0.474 million t, per annum as against the actual production of 0.24 million t, thus indicating idling of these plants by more than 50% of their capacity. Therefore it is presumed that the available capacity of these plants is sufficient to meet the first five years requirements of the additionally exploited resources also.

Diversified processing

For better utilization of the fish caught, it is but necessary to diversify the products and test their marketability. In this way several of the so called low quality fish can find better utilization. This is especially the case with respect to the large stocks of meso-pelagic resources which are yet to get accepted in the domestic markets. Technologies are now available for diversified processing of marine fish. One such method is picking meat from small and miscellaneous fishes and making it into frozen blocks known as 'Kheema', which could be used for preparing a variety of items such as fish extract, fish paste, fish flake, fish finger etc. Fish protein

concentrate is prepared from such picked meat. Bacteriological peptone useful for preparing culture media for microbial organisms is also prepared from minced fish. The fish hydrolysate can be incorporated with malt, sugar, cocoa powder etc. and dried to yield a fine beverage. The same minced fish can be used for preparing fish soup powder. Fish pickling can also be tried. With the exploitation of the additional resources as projected in the paper, large quantities of coastal tuna would be landed. It is suggested that 'mas min' (smoked tuna fish) may be produced at selected centres of southwest and lower east coast for internal marketing.

Table 17 gives the list of some of the important diversified products developed and marketed by I. F. P. Large scale adoption of these techniques would go a long way in promoting conversion of the cheaper and non-conventional varieties of fish to value added products.

TABLE - 17

Some of the important diversified products developed and introduced into the market by the Integrated Fisheries Project, Cochin during the period 1968-84

1. Deep sea lobster tails
2. Fish fillets
3. Cuttle fish and squid fillets
4. Fish Keema
5. Fish roe
6. Dried fishes
7. Fish fritters
8. Fish soup
9. Fish powder
10. Pasterised deep sea shrimp
11. Dried squid wafer
12. IQF products
13. Mas - min from tuna
14. Canned fish products in oil and brine
15. Frozen fish, crustaceans and molluscs
16. Lobster pickles

Requirement of transport facilities

Proper transport facilities are essential for this easily perishable commodity. Mode of fish transportation varies according to

type of consuming centres. Fish is transported either in fresh condition or in processed form. Processed fish includes sundried and salt cured fish and fish meal. The fresh fish for local consumption is transported in cycles or as head loads, while to far off consuming centres it is done either by truck or rail. Transportation to processing plants is also involved. However, no information is available about the average distance for transportation of different types of fish in different regions.

As mentioned earlier about two-thirds of the fish produced is consumed in fresh condition out of which about 50% is assumed to be consumed in areas nearer the coastal belt. The balance of the annual additional production, namely, 36,000 t of fish would have to be transported to longer distances. Assuming rail transport for one-fourth of this quantity, about 27,000 t of fish would have to be transported by trucks. The number of trucks required to dispose of an average daily production of 135 t would be 45 of 6 t capacity which effectively transport iced fish. Taking the average distances travelled by a truck to dispose of the fish to be 200 km, each truck could take the load only on alternate days. Thus the actual number of trucks required would be 90 for a one year period and these could be provided at the important ports. Guidelines for regionwise distribution can be had from the table giving the expected distribution of landings.

Development of marketing system

Eventhough need based arrangements for the marketing of fish in the country are in vogue, the system has to be further developed according to future needs by adopting proper management strategies. The fishermen's co-operatives which at present are not a force in themselves are to be strengthened/established in every major fish landing centre, so that many of the intermediaries could be avoided thus promising legitimate returns to the fishermen for their catches.

At present flow of fresh fish into the interior areas is rather poor for lack of proper transport and storage facilities. The fish that reaches the interior markets is often

partly spoiled. If adequate facilities for transportation (insulated/refrigerated trucks) and cold storages at the markets are available, more quantities of fresh fish could be moved to far interior areas and marketed. Therefore a chain of cold storages of appropriate capacities, based on the local demand as ascertained through consumer surveys, are to be established ('cold chain') on a country wide level.

With the exploitation of the oceanic waters considerable quantities of non-conventional but edible resources like *Chlorophthalmus* spp., *Priacanthus* sp. and *Centrolophus* sp. may be landed which may not be readily accepted by the consumers. However, if minced fish popularly known as 'fish kheema' is produced marketing may not be a problem. Mention has already been made of the several such products which can be developed.

Along with the diversification of fishery products, acceptance of the products by the public is to be ascertained. In the absence of a true picture of the marketing conditions it is difficult to precisely spell out the infrastructural requirements like cold storages, drying plants, fish meal plants and the transport systems. Comprehensive market surveys are to be conducted to ascertain the cold chain centres, capacity and number of cold storages drying facilities and routes, modes and capacity of transport system to be established for the purpose. Along with this, consumer education has to be organised for making people aware of the diversified products and their qualities.

In seasons of heavy fish catches the price of fish comes down alarmingly and this leads to poor returns to the fisherman. During such times the governmental agencies or marketing societies should enter into the market and purchase the excess fish at reasonable price and store for the lean periods. Also it is necessary that minimum support price for all varieties of fish may be fixed so that fishermen are assured of proper returns for their commodity. Such a system will encourage fishermen to land all what they catch (trash and non-conventional fish) which otherwise they throw back into the sea.

CONCLUSIONS

Since early fifties marine fish production in the country rose steadily from 0.5 million tonnes and crossed the one million mark in 1970 due to several R & D inputs. However during the mid-seventies the production reached a plateau and remained so until early eighties. The present production is of the order of 1.6 million tonnes.

Based on different approaches such as the estimates of primary production, trophic relationship, exploratory fishing, acoustic survey and exploited resources, the potential of harvestable yield of fishes in the EEZ of India was estimated at 4.5 million tonnes. Accepting this as the basic figure of the potential yield it is seen that the present production in the country leaves an un-exploited stock of about 2.9 million tonnes. This calls for immediate strategies for harvesting the additional quantities in the coming years in a phased manner. Towards the development of such a strategy an attempt has been made in this paper to bring together background information on the region-wise exploited stocks, categorywise potential resources, available infrastructure, pattern of utilisation and marketing aspects. The projection with regard to expected additional yield, infrastructure needed to achieve the targeted production and the economics of vessel operations are presented. Utilisation and marketing requirements are also discussed.

The fishing pressure at present both from artisanal and small-scale sector is mainly within the 50 m depth. It is pointed out that additional increase from this zone will be only marginal except in the case of some of the underexploited resources like white-baits and horse-mackerel. However, extension of fishing activities beyond 50 m over the shelf region will bring an additional yield in the case of resources such as small tunas, catfish, horse mackerel & scads, perches and ribbon-fish.

There are good prospects, as revealed by exploratory surveys, for the harvest of resources such as larger perches (*Epinephelus* spp., *Lethrinus* spp., *Lutjanus*, *pristipoma* spp).

from the banks and rocky out-growth off the west coast. Deep sea crustaceans comprising deep sea lobster and penaeid prawns from the continental slope and a variety of non-conventional edible finfishes such as bull's eye, Indian drift fish green eye and the black ruff as well as miscellaneous fishes like rat tails and boar fishes are available from the deeper trawling grounds

Over and above this, the potential for exploitation of larger tunas, pelagic sharks, marlins and oceanic squids, is promising from oceanic waters including the island territories of the Andaman, Nicobar and Lakshadweep. These remain virtually un-tapped at present.

Considering the fact that it has taken more than two decades to realise an additional production of one million tonnes from the level of 0.5 million tonnes in the fifties despite the steady increase in development inputs, the strategy suggested in the paper envisages introduction of additional production means and infrastructure in a phased manner, in keeping with the current realities. Attention is also drawn to the gaps in information observed in certain critical areas.

The proposed plan is summarised below with suitable recommendations.

1. In order to harvest a part of the exploitable resources, the plan is to introduce 160 additional vessels comprising 65 small purse-seiners (13.6m), 55 medium trawlers (17.5m) and 40 large trawlers (26m) during a one year period. This would result in about 0.11 million t of additional yield from the shelf and slope areas. The species-wise distribution of the expected additional yield is given in Table 7. The total investment for the purchase of crafts and gears would be about Rs. 647 million out of which Rs. 400 million would be for the large trawlers alone.

The region-wise distribution of additional vessels required for exploitation of different categories for a one year period is indicated along with suggestions for suitable gears to be operated (Table 8).

The plan envisages progressive introduction of vessels leading to an additional annual production of about 0.55 million t in the fifth year and this would result in harvesting of 5-60 percent of the exploitable yield of the selected resources.

The target resource considered are white baits, coastal tunas, elasmobranchs, cat fish, perches, croakers, ribbonfish, carangids, crustaceans and cephalopods. However for the oceanic tunas and cephalopods no estimate of projected catch and number of vessels is included in the figures stated due to want of critical data (also see item 9 under 'Conclusion').

2. The addition of vessels should be made in a phased manner with some amount of flexibility. The performance should be monitored and critical appraisal should be made year after year using feed back data on the achievements. Suitable modifications may be made, if need be, to suit the developing situation.

3. With the progressive increase in the number of vessels the requirement of trained men also increases. It is estimated that a total of about 1950 trained personnel including skippers and chief engineers would be required for a one year period to operate the proposed number of vessels (Table 9).

4. Deep sea non-conventional fishes obtained as part of the catch should be brought to the shore as they offer good potential for conversion to edible products or reduction to fish meal and manure.

Towards better utilisation of non-conventional and new resources the technological institutions should undertake product development for consumer acceptance covering a wide range of resources.

5. In the case of the three major categories of fishing units proposed, namely purse seiners (13.6 m), medium trawlers (17.5 m) and large trawlers (26.0 m) the projected economics of operations have been worked out and found to be commercially feasible (Tables 10 to 13).

6. To ensure additional production and bringing in unconventional fishes, it is desirable

to declare remunerative support price of different varieties of fish landed. Fish co-operatives could be the best agency for deciding and implementing such a programme.

7. The suggested modalities of increasing fish production in a phased manner should take into account the required infrastructure development in terms of landings, berthing, ice-plants, cold storages, fish processing plants, fish drying units, transportation and marketing. The problems involved have been broadly considered and indications have been given on future needs.

In order to make more specific recommendation about the location of cold-chains, processing plants and transportation routes and to understand the consumer behaviour and the changing demand-supply position, it is essential to carry out periodic market surveys at micro and macro levels.

8. Bulk of the coastal tuna catches currently come from the small-scale fisheries sector using drift gillnets and hooks and lines. With the increasing trend in motorisation of country crafts it is time to introduce innovations in the country craft and gear to enhance fishing capabilities and to provide icing and storage facility onboard.

In the Lakshadweep area, the existing mechanised pole and line units can be improved by introducing larger boats with adequate storage and navigational facilities.

9. There is considerable potential for the exploitation of oceanic tunas and related species. However, so far, only the skipjack and young yellowfin tunas occurring in the Lakshadweep waters are exploited and that too in small quantities through small mechanised units using pole and line. The exploratory cruises of the Govt. of India vessels have shown possibilities of tuna long lining in commercial quantities from our seas. But the data provided have shown highly varying hooking rates and it becomes difficult to project economic viability of such operations. Considering these, a table has been constructed (Table 15) indicating the expected profits in long-line operations for various combinations of tuna catch level and unit price. This would help in providing guidelines for decision making.

In the case of cephalopods, increased catches can be made by directed effort on the neritic resources and extending the fishing activities to deeper areas. Specific fishing methods such as squid-jigging, light fishing and drift gill netting are suggested as appropriate techniques and some of these require expertise from countries like Japan.

Distant water fishing using long-liners, purse-seiners and squid-jiggers, being a highly capital intensive venture in terms of cost of vessels, fishing equipments and operations, an adequate return for the investment depends on high productivity from the operations as well as easy and profitable sale of catches in internal and external markets. Expertise in fishing operations is an important contributing factor in increasing the productivity. It is desirable to have more joint ventures and/or chartering of foreign vessels at least for some more time to come so as to enhance production, develop expertise, generate confidence and make the industry economically viable.

10. In developing suitable programmes for tapping the resources it is essential that Government of India vessels undertake systematic simulated commercial fishing for target resources by different types of fishing operations. Such operations would generate a good amount of data essentially needed to confirm areas and season of fishing and arrive at the number of deep-sea vessels such as long-liners purse-seiners and squid-jiggers needed to economically exploit the oceanic tunas, tuna like species and cephalopods.

11. The export trade in our country has so far been concentrating mainly on the limited stocks of coastal shrimps even though fish exports have of late been increasing. Future strategies therefore require diversification of this export trade in much bigger way by bringing in varieties of fishes apart from crustaceans, squids and cuttle fish.

12. Most of our resources are known to exhibit seasonal fluctuations which are due to fishery independent factors. There is urgent need for integrating environmental data with resources data. At present a number of

organisations are engaged in the collection of environmental and exploratory fisheries data. It is suggested that the vessel facilities available with the different organisations under the Govt. of India are pooled together to undertake surveys of the resources and environmental studies in different regions. Bringing the vessel-based programmes under one umbrella will almost eliminate duplication of efforts and permit more efficient use of the scarce resources of vessel and specialised man power facility. The concurrent information generated on the fishery dependent and independent factors, would permit better understanding of the potential stocks in the EEZ and the contiguous seas and help not only in making short and long term fisheries forecasting but also in formulating sound management policies.

It should be mandatory that the joint venture/chartered vessels and large vessels of private enterprises must collect some minimum environmental data and provide the same along with the data on exploited resources to the concerned central organisations so as to carry out integrated analyses for better appreciation of the dynamics involved.

13. An essential component of the development strategy in marine fisheries sector is a strong data base relating to the various stages of production and distribution. For this purpose the C. M. F. R. I. has developed a National Marine Living Resources Data Centre at its headquarters with fishery and computer expertise. The centre forms an excellent store-house for all fisheries data which would help in co-ordination of research and allied activities in the marine fisheries sector. Data flow to NMLRDC from all organisations and industry should be ensured for quick processing and dissemination at national level. A mandatory provision has to be introduced for this purpose.

14. Knowledge about the specific distribution of potential marine resources, provision of improved means of production, development of infrastructure facilities for landing, storage, processing, transporting and marketing, meeting the requirements of man power and credit and a sound policy for judicious exploitation are some of the major aspects concerned

with the development of marine fisheries. Thus the total marine fisheries system has to be viewed as one comprising of several interlinking sub-systems. In order to achieve the best results a system approach has to be followed in any future strategy for exploitation and utilization of our vast marine living resources. There has been much thinking about the formation of a Marine Fisheries Development Board at the national level with adequate powers. Such a Board can co ordinate the activities of the various sub systems involved and ensure timely and effective implementation of the development programmes. It would be appropriate to consider creation of a Ministry of Fisheries to administer all activities covering the fisheries of the country.

REFERENCES

- ANON. 1974 Progress Report-No. 6, Survey results 1972-73, UNDP/FAO/Pelagic Fishery Project : 1-141.
- ANON. 1975 Papers for the third workshop on Transportation of fresh fish and utilization of trash fish, Cochin, October 1975 : 1-88.
- ANON. 1976 Report of national Commission on Agriculture. Part 8, *Fisheries Dept. of Agriculture, Govt of India.*
- ANON. 1976a Progress Report No. 12, Survey results 1973-74, UNDP/FAO/pelagic Fishery project : 1-116.
- ANON. 1976 b Progress Report No. 13. Survey results 1974-75, UNDP/FAO/Pelagic Fishery project : 1-107.
- ANON. 1981 All-India Census of Marine Fishermen, Craft and Gear-1980. *Mar. Fish. Infor. Serv., T & E. Ser. 30.*
- ANON. 1982 Trends in marine fish production in India-1981. *Mar. Fish Infor: Serv. T & E. Ser. 41.*
- ANON. 1983 Marine Small-Scale fisheries of India A general description. *BOBP/INF/3* : 1-68.
- ANON. 1985 Tuna fisheries of the Exclusive Economic Zone of India (Ed.) E. G. Silas *CMFRI Bulletin* No. 36.
- ANON. 1985 a Statistics of marine product Exports for 1985. *Marine Products Export Development Authority, Cochin.*
- ANON. 1986 *Mar. Fish Infor. Serv. T & E. Ser., 67*
- ANON. 1987 Collective volume of working documents Expert consultation on stock assessment of tunas in the Indian Ocean, Colombo, Dec. 1986. *Indo-Pacific Tuna Development and Management Programme FAO.*
- BAPAT, S. V. et al 1982 Fishery resources of the Northwest coast of India. *CMFRI Bull. No. 33* : 86 pp.
- BHADURI, S. K. 1986 All existing fishing harbours must be made operational first. *Fishing Chimes* : 6 (7) : 26-29.
- GEORGE, P. C., B. T. ANTONY RAJA and K. C. GERGE 1977 Fishery resources of the Indian Economic Zone. Silver Jubilee *Souvenir*, Integrated fisheries Project, Cochin : 79-116.
- GIRIJA, S. and K. RAVINATH 1986 Diversified fish processing and increased fish consumption. *Proc. International Seminar on Training and education for marine fisheries management and development* : 71-77.
- GOVINDAN, T. K., and M. R. NAIR 1986 Utilization of potential marine fishery resources of India. *Seminar on potential Marine Fishery Resources, Cochin*, April 23, 1986 Mimeo : 12 pp.
- JAMES, P. S. B. R., K. ALAGARSWAMI, K. V. NARAYANA RAO, M. S. MUTHU, M. S. RAJAGOPALAN, K. ALAGARAJA and C. MUKUNDAN 1986 Potential Marine Fishery Resources of India. *Seminar Potential Marine Fishery Resources Cochin*, April 23, 1986 Mimeo : 20 pp.
- JONES, S. and S. K. BANERJI 1973 A review of the central Indian Ocean, *Proc. Symp. Living Resources of the sea around India*. *CMFRI* : 1-17.
- JOSEPH K. M. et al. 1976 a Results of demersal resources survey along the

- east coast of India, 1959-1974. *Bull. Expl. Fish Project*, 3 : 53 pp Mimeo :
- JOSEPH, K. M., N. RADHAKRISHNAN and K. P. PHILIP 1976 b Demersal fisheries resources off the Southwest coast of India. *Bull. Expl. Fish Project*, 3 : 56 pp.
- JOSEPH, K. M. 1981 Observations on the fish catches of some poaching vessels intercepted along, the northwest coast of India. *Bull. Expl. Fish Project*, 11 : 21.
- JOSEPH, K. M. and M. E. JOHN 1986 Potential marine fishery resources. *Seminar on Potential Marine Fishery Resources Cochin*, April 23, 1986 Mimeo : 30 pp.
- MENON, M. D. and K. C. GEORGE 1975 Whitebait resources of the southwest coast of India. *Seafood Exp J*, 7 (1).
- MITRA, G. N. 1970 Fisheries resources of the Indian Ocean and economics of operation of fishery vessels from the Indian coast *Proc. Symp. Development of Deep sea Fisheries, Cochin*, Feb. 1970 : 80-98.
- MUKUNDAN, M. and L. A. HAKIM 1980 Purse seining-Development in Indian waters. *Bull. Integrated Fisheries Project. Cochin* : 59 pp.
- NAIR, P. V. R., SYDNEY SAMUEL, K. J. JOSEPH and V. K. BALACHANDRAN 1973 Primary production and potential fishery resources in the seas around India. *Proc. Symp. Living Resources of the seas around India. Spl. Pub. CMFRI*, pp. 184-198.
- NARAYANA RAO, K. V., M. KUMARAN and J. SANKARASUBRAMANYAN 1977 Resources of horse mackerel of the southwest coast of India. *Seafood Exp. J.*, 9 (8)
- OOMEN, P. V. 1980 Results of exploratory fishing in Quilon Bank and Gulf of Mannar. *Bull. integrated Fisheries Project. Cochin*, 4 : 49 pp.
- OOMEN, P. V. 1985 Deepsea resources of the southwest coast of India. *Bull. Integrated Fisheries Project* 11 : 83 pp.
- RAO, K. V. and K. DORAIRAJ 1973 shrimp resources of the continental shelf as revealed by trawler landings from offshore waters of India. *Proc. Symp. Living Resources of the seas around India* : 596-613.
- SILAS, E. G., S. K. DHARMARAJA and K. RENGARAJAN 1976 Exploited marine fishery resources of India-A synoptic survey with comments on potential resources. *CMFRI Bull.* 27 : 25 pp.
- SILAS, E. G. and P. V. RAO 1977 Marine fisheries research and its contribution to the fishing industry of India. *Souvenir, Silver Jubilee of IFP, 1977*, 15-18.
- SILAS, E. G. and P. P. PILLAI 1982 Resources of tunas and related species and their fisheries in the Indian Ocean. *CMFRI Bull.*, 32 : 174 pp.
- SILAS, E. G. et al. 1986 Exploited marine fishery resources and its contribution to Indian Economy. *CMFRI spl. pub.* 29 : 32 pp.
- SIMPSON, A. C. and S. CHIKUNI 1976 Progress report on fishing for tuna in Philippine waters by FAO chartered purse seines- *Working paper SCS 76 WPI35 FAO South China Sea Fisheries Dev. and Coordinating Prog.* : 35 pp.
- SWAMINATH, M., M. K. R. NAIR and P. P. RAVIN 1986 Oceanic tuna-a feasible fishery in Indian EEZ. *CIFNET Bull/O3/MFR* : 72 pp.
- JOSE, LUIS CORT 1982 The fishing of tuna in the Seychelles Islands, "Hoja del mar", Oceanographic Institute, Madrid (Spanish)

EXPLOITATION OF JUVENILES OF GREEN TIGER PRAWN, *PENAEUS (PENAEUS) SEMISULCATUS*, ALONG PALK BAY AND ITS IMPACT ON THE PRAWN FISHERY OF THE REGION

P. E. Sampson Manickam, M. R. Arputharaj and P. Vedavyasa Rao
*Central Marine Fisheries Research Institute, Mandapam Regional Centre,
 Mandapam Camp*

ABSTRACT

The green tiger prawn, *Penaeus (Penaeus) semisulcatus*, contributes to over 50% of the total prawn catch landed along the Palk Bay coast. They are caught by the indigenously developed trawl-like bottom nets and trawl nets operated by non-mechanised and mechanised fishing vessels within the 12 metre depth zone. With the increasing demand for prawns by the export trade, intense fishing for juvenile prawns which inhabit the seagrass ecosystem near the shore is taking place all along the coast. The results of the survey carried out on this exploitation pattern are reported in the paper.

Fifty villages from Adirampattinam in the north to Thangachimadam in the south serving as bases for the operation of 2,500 indigenous fishing crafts are involved in the fishery. They are operated mainly during night and the area of operation is the 3-4 metre depth zone from the shore. The gear used is basically a miniature two-seam bottom trawl net without otter boards. The mouth opening of the net is maintained by two sticks provided at the wings of the net. The cod-end mesh size of the gear ranges from 5mm to 25mm. Depending on the size of the boat, either a single net or two nets are operated. Wind power using 1 to 3 sails is utilized for effective trawling. Besides this, juvenile prawns are also caught by small trawl nets tied to hip and dragged along the bottom very near the shore by two persons.

The prawn catch, the bulk of which is composed of juvenile *Penaeus semisulcatus*, is found to vary from 2 kg to 10 kg per day. The size of the exploited *P. semisulcatus* ranges from 31 mm to 100 mm total length with the dominant size group at 45-70 mm. Besides prawns, each unit also takes about 5 kg of seagrass and seaweeds per haul.

Although the operation of bottom trawl nets by sail boats for prawns in this region is known since one and half decades, such intensive fishing by indigenous crafts and gears in the very near shore waters throughout the year is a recent development. As the catch is composed exclusively of small sized juvenile prawns and since the nets are operated in the seagrass beds which form the nursery grounds for the prawn resources, the impact of this exploitation on the overall *P. semisulcatus* resource in the region is discussed.

INTRODUCTION

The Palk Bay extending from Point Calimere to Dhanushkodi with a coast line of about 274 km on the southeast coast of India is a large embayment. It is shallow and contains congenial habitat for penaeid prawns that are commercially exploited. With the initiation of operation of mechanised fishing boats with trawl nets in the early sixties and establishment of shore and base facilities at certain centres such as Remeshwaram, Mandapam, Kottaipattinam, Jegathapatnam and Mallipattinam, the prawn fishery of the region gradually expanded to produce at present about 6,840 tonnes of prawns annually.

Over the years, this expanding fishery witnessed certain changes in the exploitation pattern, species composition and gear deploy-

ment. In the sixties, the principal species in the prawn fishery of the Palk Bay was *Metapenaeus affinis* (James and Adolph, 1965). Since the early seventies, *Penaeus semisulcatus* formed the major species contributing to about 89% of the prawn catch of the area (Nandakumar, 1980). Similarly, besides the conventional bottom trawl nets operated by small mechanised boats, several indigenously developed nets, simulating the trawl nets and operated by non-mechanised boats have been introduced to capture prawns. While these crafts and gears have until recently been capturing the adult prawns in the Bay, considerable number of these units are in recent times being employed to capture juvenile *P. semisulcatus* inhabiting the near shore waters. This situation has stemmed from the increasing demand for prawns in the export trade, the

increasing fishing pressure and the fluctuating production trend. As the large scale exploitation of the juvenile *P. semisulcatus* would affect the overall stock of the species in the Bay and since the information on such exploitation is of vital importance in the rational management of the resource, a survey is carried out on the juvenile prawn fishery of this area. The results of this survey are presented and discussed in this paper.

MATERIAL AND METHODS

The survey was conducted during January-May, 1987. 77 fishing villages along the Palk Bay coast from Thangachimadam in the Rameshwaram island in the south to Point Calimere in the north were visited. During the visit, information on the number and type of the boats employed in the juvenile prawn fishery, size of the nets and mesh size and modes of their operation and characteristics of the fishing ground such as nature of the bottom, depth and availability of seagrass was collected.

To study the species and size composition of the catch, random samples of prawns weighing about one kg, were collected from the boats operating at four ecologically different grounds of: 1) less than 2 m depth having profuse vegetation of seagrass; 2) 2 to 4 m depth with seagrass beds; 3) 4 to 5.5 m deep with patchy seagrass beds and 4) 4 to 9 m deep with muddy bottom. Prawn samples were also collected from the nets with different mesh size operating in these grounds.

The size of prawns presented in the paper relates to the total length measured from the tip of rostrum to tip of telson.

SURVEY AREA

The Palk Bay, bordered by a more or less semicircular coastline is a shallow, flat basin, the maximum depth not exceeding 13 m to a considerable distance from the shore. About 12 rivers drain to the sea along this coast, particularly during the north-east monsoon season. The most important of these rivers are Vaigai, Vellar, Ambuliar, Maharaja Samudram and branches of Cauvery draining at Muthupet area. The coastline between Devipatnam and

Adirampatnam is beset with several creeks in between the villages, where mangrove vegetation of varying intensity is available. Similarly, the coast between Adirampatnam and Point Calimere has several mudflats besides the extensive mangrove, including the well-known Muthupet mangrove swamp.

On the basis of the topographical features and the nature of the sea bottom in the inshore region, the Palk Bay coast can be divided into three regions. The northern part of the coast extending from Point Calimere to Kollukkadu is characterised by muddy bottom upto about 5.5 m depth zone; the central part from Kollukkadu to south of Devipatnam has extensive seagrass beds near the shore while southern region from Devipatnam to Thangachimadam in the south has intermittent sandy and muddy bottom except for a 5 km stretch on either side of Mandapam, where the sea bottom is beset with seagrass beds and coral patches.

Although the information on the hydrographical features of the waters of the Palk Bay is available mainly from the work of Murty and Varma (1965), several studies have been carried out on the physico-chemical conditions and primary and secondary production of Mandapam area (Jayaraman, 1954; Prasad 1958; Nair et al., 1973). These investigations have shown that the Bay of Bengal waters entering through the Palk Strait greatly influence the hydrological parameters such as temperature, salinity, surface density and dissolved oxygen of the ecosystem. The near shore waters is generally characterised by relatively higher temperature, lower salinity and density than the offshore waters. The inshore regions of Palk Bay are also found to have high levels of primary production. These features, as well as the presence of seagrass beds afford congenial habitat for the juvenile penaeid prawns to grow.

The current-pattern and the wind flow over the Palk Bay show regular seasonal cycle corresponding to the south-west and north-east monsoons. In the southern part of the Bay, the predominant current is south easterly from May to September. In October and from February to the end of April the current is found to be

TABLE : 1

Name of the landing Centre		No of non-mechanised sail boats Involved in the fishery			Total
		Large (11-14 m)	Medium(7 10 m)	Small(below 6 m)	
1. Akkalmadam	(S)	—	200	—	200
2. Devipatnam	(P)	40	100	56	196
3. Thirupalaikudi	(P)	150	50	—	200
4. Morepannai	(P)	71	62	—	133
5. Karangadu	(P)	66	30	—	95
6. Mullimunai	(P)	120	6	—	126
7. Pudupatnam	(E)	44	23	—	67
8. Soliakudi	(E)	25	—	15	40
9. Nambuthalai	(S)	125	—	—	125
10. Thondi	(P)	97	56	30	183
11. Valasaipatnam	(E)	15	—	—	15
12. Narambal	(2)	22	—	—	22
13. Demodaranpatnam	(E)	41	10	—	51
14. Pasipatnam	(E)	120	25	40	185
15. Theerthanathandam	(E)	5	—	—	5
16. Puththukuda	(E)	45	—	—	45
17. Arasanagiri	(E)	—	—	4	4
18. Puthoor	(S)	131	67	—	198
19. Gopalapatnam	(P)	49	—	—	49
20. Iyenpatnam	(E)	27	—	—	27
21. Kottaipatnam	(E)	34	—	—	43
22. South Pudukudi	(P)	42	—	—	42
23. North Pudukudi	(E)	75	—	—	75
24. Ammapatnam	(S)	12	—	—	12
25. Thulasapatnam	(S)	62	—	—	62
26. Nsrth Ammapatnam	(E)	70	—	—	70
27. Krishnajipatnam	(E)	16	—	—	16
28. Prathabharamanpatnam	(E)	20	—	—	20
29. Kattumavadi	(E)	35	—	—	35
30. Sembumadevipatnam	(E)	90	—	—	90
31. Vallabhanpatnam	(E)	15	4	—	19
32. Somanathanpatnam	(E)	19	—	—	19
33. Puthutheru	(E)	9	15	—	24
34. Manthiripatnam	(E)	11	15	—	26
35. Senthalaipatnam	(E)	73	—	—	73
36. Sembaipatnam	(E)	68	—	—	68
37. Karanguda	(E)	11	—	—	11
38. Oththaiveedu	(S)	2	—	—	2
39. Kazhumanguda	(E)	44	—	—	44
40. Setnubhava Chatram	(S)	30	—	—	30
41. Pillayarathidal	(P)	4	—	—	12
42. Manora colony	(S)	1	—	—	1
43. Chinnamani	(S)	15	—	—	15
44. Pudupatnam	(S)	20	5	—	25
45. Kollukadu	(E)	16	—	—	16
46. Allathikadu	(S)	15	—	—	15
Total :		2001	676	145	2822

(E) - Villages, where all the fishermen are engaged in the capture of prawns throughout the year. (27)

(P) = Villages, where only some of the fishermen are involved in the fishery throughout the year. (9)

(S) = Villages, where fishermen are involved in the fishery only during peak fishing season. (10)

variable, while in December and January, the main current is south westerly across the Gulf.

VILLAGES INVOLVED IN THE JUVENILE PRAWN FISHERY

Of the 77 fishing villages surveyed, fishermen of 46 villages are found to exploit the juvenile *P. semisulcatus* either through out the year or during October-December which forms the peak fishing season for the species. On the basis of involvement of fishermen in the fishery the 46 villages are further classified into three categories, namely: 1) villages where all the fishermen are engaged in the capture of prawns throughout the year (27 villages); 2) villages where only some of the fishermen are involved in the fishery throughout the year (9 villages) and 3) villages where fishermen are involved in the fishery only during the peak fishing season (10 villages), (Table 1). It may be noted that most of the villages in the lower half of the coast are engaged in the fishery throughout the year. At one of the villages in the southern coast, Akkalmadam, the fishermen go for prawn fishing only during April-October. During the other months, they migrate to Gulf of Mannar as the wind flow becomes unfavourable for the operation of sail in this coast.

The availability of prawns throughout the year in the fishing ground and the monsoonal winds blowing over the Bay favour round the year operation of sail boats particularly in the western region of the coast. The lean season found during February-April coincides with the less breezy transit period from north-east to south-east monsoon, when the wind direction is also found to be erratic.

Fishing for juvenile *P. semisulcatus* is generally carried out during night. In the day time the fishermen go for crab and or cephalopod fishing.

CRAFTS AND GEARS EMPLOYED IN THE FISHERY

Crafts

Non-mechanised, flat bottom, wooden, plank-built boats are employed exclusively in the juvenile prawn fishery of the area. In the

46 villages surveyed at present, 2,822 boats are engaged in the fishery. Of these, 2,001 larger boats measure 11-14 m, 676 medium size boats are 7-10 m long and 145 smaller boats measure less than 6m (Table 1). The design and construction of these different size boats are basically similar.

Sails and wind energy are used for the propulsion of the boats and the operation of nets. The larger boats use upto three sails, the medium size boats two and the smaller boats one. The larger boats, in the lower half of the west coast (from Devipatnam to Pasipatnam), operate 2 nets while in the upper region, they use only one net. All the other boats use only one net. Though 2,822 boats are involved in the fishing, only 1,126 boats (970 larger, 112 medium and 44 smaller) are engaged in the fishing throughout the year and the rest only in the seasonal fishing.

The boats are constructed mainly at Thirupalaikudi, Thondi and Adirampatnam. The construction cost of the larger boat (14 m size) is found to be about Rs 25,000 and of the medium size about Rs 9,000/-.

Gears

The gear operated by the sail boats is locally known as '*Thallu valai*' and essentially resembles in its design a small two seam shrimp trawl without otter boards. The size of the net varies from 10 m to 18 m. Generally, the 18 m long net is operated by the larger boats (14 m); while the net of 12 m size by the medium boats or in the twin net operation by the larger boats. The smaller nets of 10 m size are mainly used in the medium as well as smaller boats.

The net is made up of blue HDPE twines. The webbing used for the net vary at different part of the net. The body and the wing are fabricated by 0.75 mm twine with mesh size of 10 to 20 mm in the former and 25 to 35 mm in the latter. The cod-end which is relatively longer as compared to the size of the net is made of 1 mm twine with mesh size varying between 7 mm and 15 mm. 6 to 8 mm diameter ropes of HDPE material are used for head and foot-ropes of the net. An iron chain weighing about 8 to 10 kg is provided at the foot-rope. The chain is tied to the foot-rope at 20 cm interval all

along its length. But in certain villages, the chains are provided after leaving a few metres on either side of the foot-rope. The head-rope contains 6 to 7 floats. A float as well as a sinker is attached to the cod-end. The warp rope used is generally of 20-25 mm thickness, made of HDPE. To facilitate proper spread of the net, spreader sticks ranging from 45 cm to 90 cm in length and 25 mm in diameter are used. The cost of the nets ranges from Rs. 500 to Rs. 1,000/- depending on the size of the net. Often, the nets are made utilising the used pieces of trawl nets.

Operation of nets

In the single net operation, the 'Thallu velai' is rigged from any one of the lateral sides of the boat. In order to facilitate maximum coverage of the area and mouth opening of the net during operation, one wooden pole is tied at the front and another similar pole at the rear part of the boat. To the tip of these poles, the warp ropes are tied securely and the net is shot into the water. In the twin net operation, two nets of same size are kept side by side and the inner warp rope of each of the net is tied together so as to form a single warp line, thus the two nets while in operation have only three warp lines. As in the case of single net operation; the outer warp ropes are tied to the front and rear portion of the boat and the central warp line at the middle. The entire combination of nets is thus balanced on a cross beam.

The nets are generally dragged parallel to the coast for one hour duration at a speed of about 1 km/hr. As the nets are operated at the side, the boat moves laterally forwards. Irrespective of size of the boat and the net, these units are operated by two persons, generally an adult male and a boy of 12-15 year old, for single net operation.

Besides the above gear, smaller nets less than 10 m long with almost the same design, but having a scare line attached to the warp rope are operated in shallow waters, by two fishermen or fisherwomen, wading in the water with the warp attached to their waist. In recent times, this gear is gaining popularity and increasingly used in certain areas of the coast.

THE FISHERY

Species composition

An analysis of the catches landed by the units operating within 5.5 m depth zone over the seagrass beds showed that juveniles of *P. semisulcatus* contributed about 95% of the prawn landings. At a few centres such as Devipatnam, Mullimunai, Narambal and Soliakudi, *Penaeus latisulcatus*, *Metapenaeus burkenroadi* (35-78 mm) and *Metapenaeopsis stridulans* (38-66 mm) were also encountered in the catches along with *P. semisulcatus*. However, the percentage contribution of these species was only about 5-10% of the total prawn catch. In the other centres, the catch was exclusively composed of *P. semisulcatus*.

At Eripurakkara and Point Calimere which are on either side of Muthupet swamp, the species composition of the catch was totally different. At these centres, the catch was composed of *Metapenaeus dobsoni* (43-73 mm), *P. merguensis* (88-123 mm), *Parapenaeopsis stylifera* (51-108 mm) and *P. indicus* (78-114 mm) in that order of abundance, although the same type of gears are employed. *P. semisulcatus* was not encountered in the catches of this area.

Size composition

The overall size range of *P. semisulcatus* population exploited by the non-mechanised sail boats operating 'Thalluvelai' between the shore and 9 m depth zone was found to be between 23 mm and 128 mm. The bulk of the the catch was formed of juvenile prawns measuring between 33 mm and 68 mm, with a modal size at 38-43 mm.

The analysis of the size composition of prawns landed at 11 fishing villages showed that the exploited population of *P. Semisulcatus* at Devipatnam, Mullimunai, Pudupatnam, Soliakudi, Valasaipatnam and Narambal was similar in size. In all these centres the modal size was 53 mm, within the major size group of 43-63 mm and the size range of 23-123 mm. However, at Pasipatnam, it was formed of smaller size prawns measuring between 23 mm and 58 mm with a modal size at 33 mm. This was mainly due to the large scale operation of

manually operated nets in the very shallow waters of less than 1.5 m. In contrast, the prawn catches landed at Puththukuda, Krishnajibatnam and Kazhumanguda were found to be composed of juveniles of relatively larger size 48-103mm. Still larger size prawns (58-128) were exploited from Akkalmadam.

Analysis of size composition of prawn catches obtained from different grounds (Fig. 1) having extensive seagrass beds, patchy seagrass areas and muddy bottom and at different depths between the shore and 9 m depth zone showed that *P. semisulcatus* ranging in size from 23 mm to 73 mm with a modal size at 38 mm predominated in the shallow waters (less than 2 m), characterised with extensive seagrass beds. In the slightly deeper zone (2-4 m) with seagrass vegetation, the dominant group of prawns caught had the modal size at 53 mm within

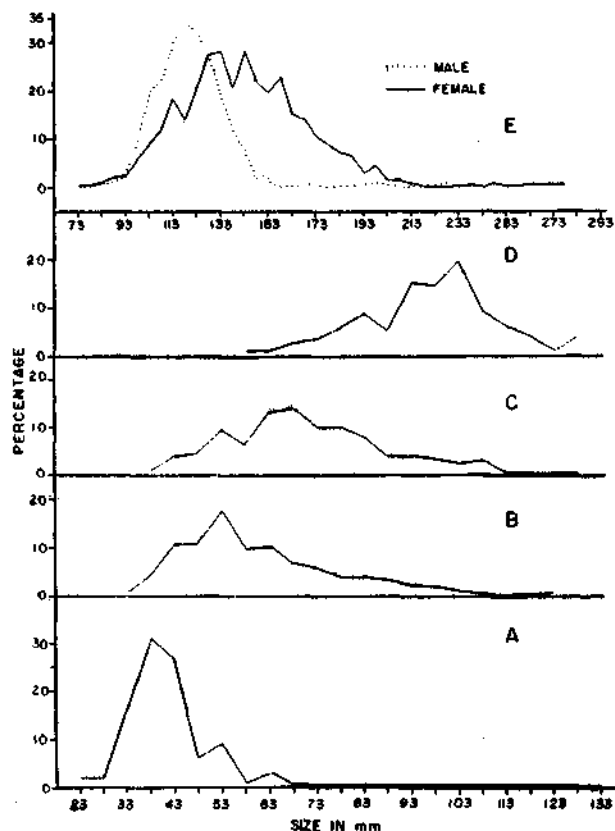

Fig. 1. Size distribution of *Penaeus semisulcatus* from different grounds.

(A) from less than 2 m depth having extensive seagrass beds; (B) from 2 to 4 m depth with seagrass vegetation; (C) from 4 to 6 m depth with patchy seagrass bed; (D) from 4 to 9 m depth muddy bottom; (E) from the open water by trawl fishing.

the size range of 33-123 mm. In the depth zone between 4 and 6 m, having patchy seagrass bottom, the prawns measuring from 38 mm to 128 mm with the modal size at 68mm formed the bulk of the catch. In the muddy grounds of 4 to 9 m deep, relatively larger prawns (size range 58-128 mm, modal size 103 mm) predominated in the catch.

To find out whether the nets with different cod end mesh size of 7 mm, 10 mm and 15 mm operated in the region selectively catch the prawns, the size composition of the catches obtained by these nets were analysed (Fig. 2). It was found that although, the size of the prawns caught by the nets having 7 mm 10 mm and 15 mm cod end mesh was 38-98, 33-108 mm and 38-123 mm mm respectively, the modal size was at 53 mm irrespective, of the difference in the mesh size.

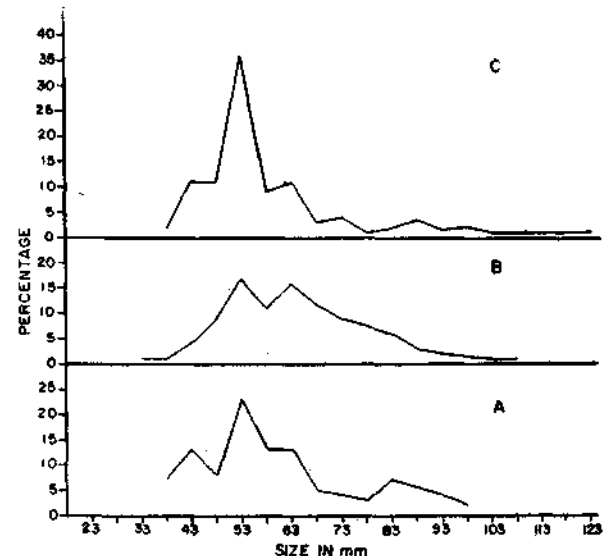

Fig. 2. Size distribution of *Penaeus semisulcatus* caught by nets having different cod end mesh sizes, (A) 7 mm cod end mesh size; (B) 10 mm cod end mesh size; (C) 15 mm cod end mesh size.

Estimation of total prawn catch and its disposal

Reliable information on the total quantity of juvenile prawns exploited by the non-mechanised units in the area surveyed is not available. As the survey is carried out only for a short period such information could not be collected. However, by actual observation of the catches landed at the time of visit to the different villages and by enquiry, it is estimated that the total catch of prawns realised per boat

during a night's operation is about 2-3 kg in the lean fishing season of February-April. During the peak fishing season, the catch of prawns amounts to 10 to 20 kg per boat. On the basis of this information and considering the number of units involved in the fishery throughout year and in the seasonal fishing and other relevant information gathered on the magnitude of the fishery during the survey, it is estimated that about 4,775 t of juvenile prawns are caught annually along the region surveyed at present.

The prawn catch is disposed off locally. In the case of the boats not owned by the fisherman, 1/3 of the catch is taken by the owner of the boat. Besides, in certain cases, he purchases the remaining catch also on a prefixed rate. In the other cases, the prawns are collected by the agents of processing units, who advance money once or twice a year. Although, the price of prawns varies from season to season and is size dependant, it is reported that even the tiny prawns of 50 mm size fetch Rs. 10-15 per kg.

DISCUSSION

The Palk Bay and the Gulf of Mannar on the southeast form the major fishing area for *Penaeus semisulcatus* along the Indian coast. Two identifiable commercial prawn fisheries exist in the area. One is a trawl fishery by about 1,200 mechanised vessels based mainly at Rameswaram, Mandapam and Mallipattanam centres. Although, *P. semisulcatus* forms the main species in this fishery, other important species caught along with this include *Metapenaeus affinis*, *M. monoceros*, *Penaeus indicus*, *P. merguianis*, *P. monodon*, *P. canaliculatus*, *Metapenaeopsis stridulans*, *Parapenaeopsis stylifera*, *P. uncta*, *P. maxillipedo*, *P. tenella*, *Trachypenaeus pescadorensis*. (Nandakumar, 1983). The trawl fishing is by and large carried out in the open waters beyond the coral reefs of the Bay. The other fishery is by non-mechanised boats employing indigenous gears whose catch is almost exclusively formed of *P. semisulcatus*. It is only in recent years that this fishery which is carried out in the shallow near shore waters, received the momentum.

The shallow flat grounds and the ecological factors such as higher temperature, relatively lower salinity and extensive seagrass beds in the near shore waters of the Bay afford congenial habitat for both juvenile and adult *P. semisulcatus*. The size distribution of the species obtained from different grounds shows that the juvenile prawns occur predominantly in the shallow waters of less than 2 m deep. As they grow to larger sizes, they move to and occupy deeper waters and the adults which support the trawl fishery inhabit the open waters of the Bay. This indicates that the juveniles prawns inhabiting the shallow grounds constitute the main sources of recruitment to the adult fishery in the deeper grounds. Further, the size distribution of the species from different villages also shows that relatively smaller juveniles are abundant in the catches landed from the areas which have higher concentration of seagrass sites, while the catches obtained from the grounds devoid of seagrass or with lesser concentration are composed of larger size prawns. This spatial variation in the distribution of different sizes of the species vis-a-vis the nature of the habitat indicate that shallow waters of the Palk Bay where seagrass abound, form the nursery ground for the species. This observation agrees with the earlier observations by Basson *et al.* (1977), Price (1979 a & b), Mohamed *et al.* (1981), Tom *et al.* (1984) and Manisseri (1986) that the postlarvae and juveniles of *P. semisulcatus* are dependent on seagrass beds which form an important nursery area for the species. As a corollary to the seagrass areas in the Palk Bay coast, there are several mangrove systems in the adjacent coastal zone from Devipattanam to Sembai-pattanam. This ecosystem would also play an important role in the nursery phase of the species in this part the coast.

Although nets with different mesh size (7 mm to 15 mm) at the cod end are employed in the fishing, significant variation in the size composition of prawns caught by these nets has not been observed. This is mainly due to the fact that appreciable quantity of seagrass gets entangled in the net and blocks the effectiveness of the different cod end mesh sizes. It is also observed that the operation of these nets causes considerable destruction of

seagrass vegetation, as about 5 to 10 kg of seagrass are removed from the system during each operation of these units. The destruction of the seagrass beds is also likely to affect the populations of dugong and green turtles which feed on sea grass.

The survey carried out at present has indicated the large number of boats and varieties of gears which are suitably modified to suit the local grounds, involved in the exploitation of the juvenile *P. semisulcatus* and its magnitude. Lured by the high price even for tiny prawns, offered by the processing industry the farmers and labourers including even the women folk engaged in agriculture are also involved in this fishery in certain villages.

As the exploitation by non-mechanised fishing vessels is mainly concentrated on the juvenile resource in the nursery areas and since these juveniles form the main source of recruitment to the adult fishery in the open and more deeper waters, it is natural to expect that large scale exploitation of juveniles would adversely affect the dynamics of the overall *P. semisulcatus* resources in the area. Besides, the destruction being caused to the seagrass beds during the operation of nets would in the long-range lead to adverse ecological changes in the nursery habitat. Although the relationship between the mangroves, seagrass and the prawn catches cannot be established in the present study, it is now well known that any change in these habitats as well as indiscriminate exploitation of juvenile stock have obvious implications for the management and future prospects of the prawn resources of the area (Staples *et al.*, (1985). In this context, it is interesting to note that the catches of adult *P. semisulcatus* in the trawl fishery of the area has been showing a gradual decreasing trend from 4,711 t in 1982 to 2,999 t in 1985. Detailed studies on the relationship between the density of juvenile prawns and seagrass system on the one hand and between the juvenile and adult stocks on the other, are necessary to elucidate the implication of these effects on the dynamics of the resource in the area.

As the exploitation of the juvenile prawns in the Palk Bay is being carried out by artisanal fishermen, its regulation and/or management

would involve consideration of social and economic implications besides the biological and fishery aspects. In this context, the possibilities of retrieval of smaller specimens caught by these nets in live condition as seed for further aquaculture in the coastal grow-out system are worth further consideration.

ACKNOWLEDGEMENT

Authors are grateful to Dr. P.S.B.R. James, Director, C. M. F. R. I., for his guidance and encouragement during the course of this work. They are also thankful to Shri M. S. Muthu, Head of Crustacean Fishery Division, C.M.F.R.I., for his valuable suggestions.

REFERENCES

- BASSON, P. W., BURCHARD, J. E., HARDY, J. T. AND PRICE, A. R. G. 1977. Biotopes of the western Arabian Gulf: marine life and environments of Saudi Arabia. Aramco, Bahrain, Saudi Arabia. 284 pp.
- JAMES, P. S. B. R. AND ADOLPH, C. 1985. Observations on trawl fishing in the Palk Bay and Gulf of Mannar in the vicinity of Mandapam. *Indian J. Fish.*, 12A (2) : 530-545.
- JAYARAMAN, R. 1954. Seasonal variations in salinity, dissolved oxygen and nutrient salts in the inshore waters of the Gulf Mannar and Palk Bay near Mandapam, (S. India). *Ibid.*, 1 : 345-364.
- MANISSERI, MARY K. 1986. On the fishery of *Penaeus semisulcatus* and its distribution in relation to depth along Tinnevely coast, Southern India. *Ibid.*, 33 (4) : 402-412.
- MOHAMED, K. H., EI-MUSA, M. AND ABDUL-GHAFFAR, A. R. 1981. Observations on the biology of an exploited species of shrimp, *Penaeus semisulcatus* de Haan, in Kuwait. *Kuwait. Bull. Mar. Sci.* 2 : 33-52.
- MURTY, A. V. S. AND UDAYA VARMA, P. 1965. The hydrographical features of the waters of Palk Bay during March,

1963. *J. Mar. biol. Ass. India*, 6 (2) : 207-216.
- NAIR RAMACHANDRA, P.V., SYDNEY SAMUEL, JOSEPH, K. T. AND BALACHANDRAN, V. K. 1973. Primary production and potential fishery resources in the seas around India. *Proc. Symp. on living resources of the seas around India*, Special publication, CMFRI., pp 184-198.
- NANDAKUMAR, G. 1980. Observations on the prawn fishery of the Mandapam area. *Indian J. Fish.* 27 (1 & 2) : 257-260.
1983. Change in species composition of prawns in the trawl fishery at Mandapam. *J. mar. biol. Ass. India*, 20 (1 & 2) : 181-183.
- PRASAD, R. R. 1958. Plankton calendars of the inshore waters at Mandapam, with a note on the productivity of the area. *Indian J. Fish.*, 5 (1) : 170-188.
- PRICE, A. R. G. 1979 a. Temporal variations in abundance of penaeid shrimp larvae and oceanographic conditions off Ras Tanura, western Arabian Gulf. *Estuarine Coastal Mar. Sci.*, 9 : 451-465.
- 1979 b. Saudi Arabian Gulf shrimp resources. *Proc. Saudi Biol. Soc.*, 3 : 293-302.
- STAPLEŠ, D. J., VANER, D. J. AND HEALER, D. S 1985. Habitat requirements of juvenile penaeid prawns and their relationship to off shore fisheries. *Second Aust. Nat. Prawn Sem. NPS 2*, Cleveland, Australia, pp 47-54.
- TOM, M., SHLAGMAN, A AND LEWINSTON, C. 1984. The benthic phase of the life cycle of *Penaeus semisulcatus* de Haan (Crustacea Decapoda) along the southeastern coast of the Mediterranean. *PSZNI : Mar. Ecol.* 5 : 229-241.

PROSPECTS FOR INCREASING CEPHALOPOD PRODUCTION OF INDIA

K. Alagarwami and M. M. Meiyappan
Central Marine Fisheries Research Institute, Cochin - 31

ABSTRACT

From the order of a 1000 tonnes in 1973 the cephalopod production has risen to the order of 43,000 tonnes in 1986. With aimed fishing, it is certainly possible to increase production of squids and cuttlefishes from the presently exploited zone. Under the aegis of the Marine Products Export Development Authority certain actions have been initiated in this direction in the recent past at experimental fishing level. Going by the data of some of the chartered fishing vessels that operated in the Indian waters during the last five years, squid and cuttlefish resources in the neritic waters appear to be substantial.

Octopus production reported from Lakshadweep is very nominal, being about 16 tonnes/annum. Scope, if any, for improving this production and exploring new grounds needs detailed investigation.

From the oceanic waters of EEZ and beyond, the prospects are for the oceanic squids, considered next only to the tuna resources in importance. However, the information on the resource is more of a qualitative and indicative nature from the operation of research vessels in the Arabian Sea such as R. V. *Varuna* and R. V. *Shoyo Maru* and presently F. O. R. V. *Sagar Sampada*.

In the above background, the paper discusses the research and development needs for increasing production of cephalopods in India and suggests an organised cooperative programme among the governmental agencies concerned on the one hand and the industry on the other.

INTRODUCTION

Production of cephalopods in India showed a phenomenal increase during the last two decades from an order of a thousand tonnes in 1966 to an order of forty thousand tonnes in 1986. Even as the total marine fish production of the country stagnated between 1.2-1.4 million tonnes in the decade 1973-1982, cephalopods showed a consistent upward trend increasing from 1394 t to 15,799 t during the same period. No special fishing effort has been responsible for this, as the squids and cuttlefishes are incidentally caught by the shrimp trawl and other gears as bye-catch. It is the import needs of Japan, starting from the early seventies, that turned the table in favour of cephalopods which had till then been thrown overboard by the boats. Starting from an order of Rs 200,000 in 1973, the export earnings by cephalopods stood at Rs. 135,660,000 in 1985.

Apparently the trend suggests that the cephalopod fishery is in an expanding stage with reference to the effort. However, the neritic species of loliginids and sepiids have only a limited potential in the shelf region. In

the world total fish catch, cephalopod contribution, despite industrial fisheries carried out by Japan, Spain, Italy and Republic of Korea in various areas, is only a small proportion of 1.5-2.1%. India's cephalopod contribution is already in this range and 1986 contribution was 2.5%. The additional potential in the coastal waters may be limited. The under- or unexploited pelagic ommastrephid squids seem to have a tremendous potential in the world oceans (estimated potential 60-70 million t according to Voss, 1973). A quantum jump in cephalopod contribution of India would be possible only from the EEZ. The moot question is how India proposes to meet this challenge to increase production in time when Japan's requirements for cephalopods are on the increase before other additional sources of supply are established by Japan.

GROWTH AND STATUS OF CEPHALOPOD FISHERY IN INDIA

Hornell (1950) described the 'squid machines' used for hand jigging of squid from a look-out erected in the shallow waters of

Rameswaram Island. In the same publication, he dealt with the method of fishing for octopus using *Pterocera* shell-lines in the Palk Bay. The squid and octopus were caught for use as bait in fish hooks, as these animals formed an excellent bait. Rao (1954) later described the fishery of Palk Bay squid *Sepioteuthis lessoniana*. The squid was consumed by certain class of people in the coastal areas. With the programme of mechanisation and development of shrimp fishing in the sixties, more of squids and cuttlefish were caught but not landed as they had no value in the market. Only the cuttlebones had an export market and, between 1963 and 1972, the export of cuttlebones ranged from 421 kg to 27,228 kg. Cephalopod production during the above period ranged from 260 t to 1517 t.

All-India production of cephalopods

The export market for cephalopod marine products commenced in 1973 for frozen cuttlefish, 1974 for frozen cuttlefish fillets and in 1975 for frozen squids. Thereafter those caught in the trawlers and other gears were saved and the landings showed steady increase. The growth in Cephalopod production since 1973 is shown in Fig. 1. Except for the decrease in 1980 and 1981, the curve has been an ascend-

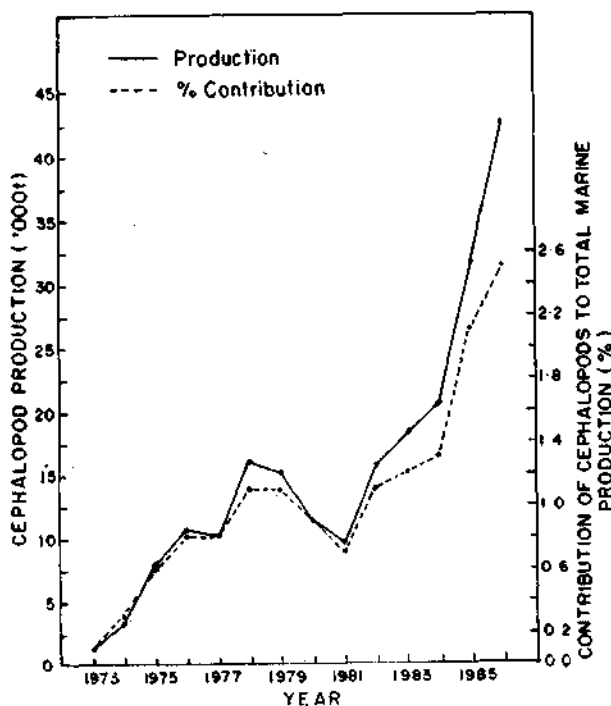

FIG. 1. Growth in cephalopod production and its contribution to total marine production.

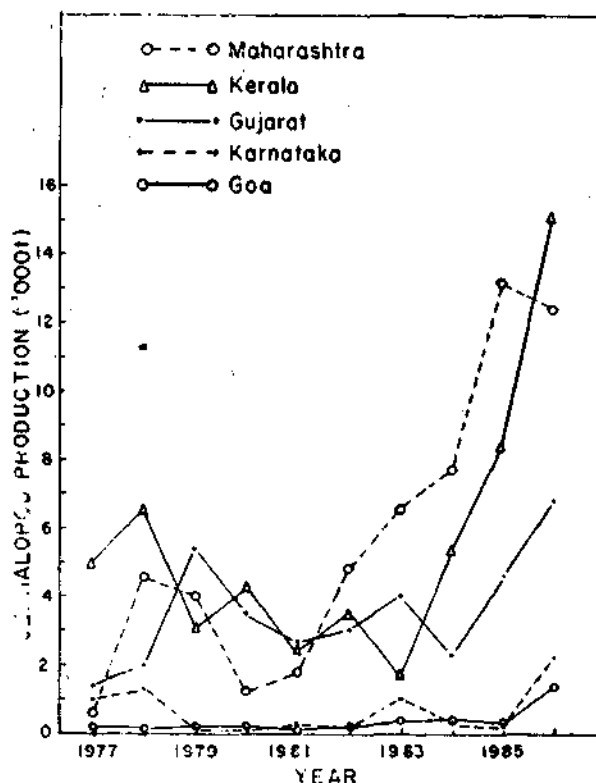

FIG. 2. Trend in cephalopod production in maritime States along the west coast.

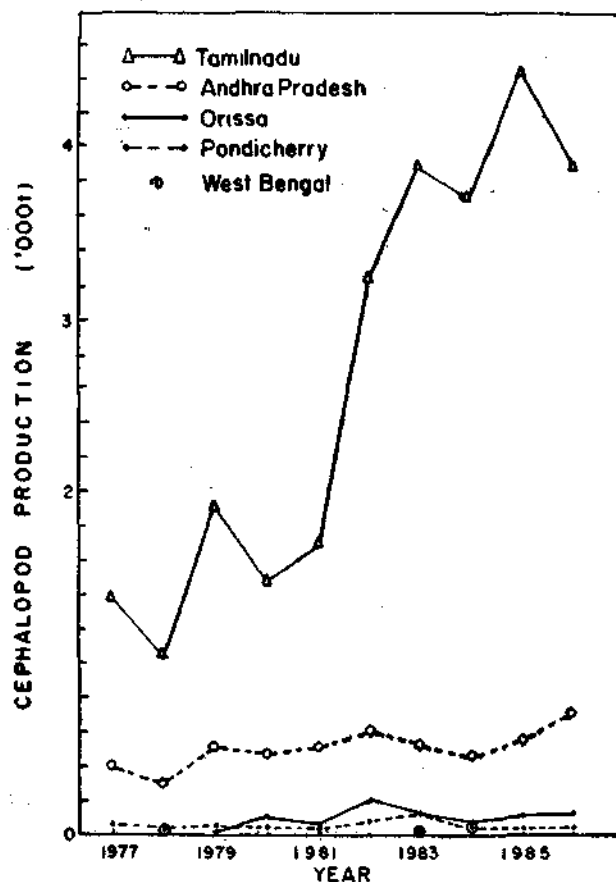

FIG. 3. Trend in cephalopod production in maritime States along the east coast.

ing one, from 1394 t in 1973 to 42,638 t in 1986. The share of cephalopods in total marine fish production steadily increased from 0.1% in 1973 to 2.5% in 1986.

State-wise production

Production along the west coast (Fig. 2) has dominated the cephalopod landings of India with 69-91% contribution as compared to 9-31% from the east coast (Fig. 3) during the recent decade 1977-1986. On the west coast the average annual landings of the decade were as follows.

	Annual production of cephalopods (t)	% contribution to total cephalopod production of India
Maharashtra	5661	29.7
Kerala	5510	29.0
Gujarat	3565	18.7
Karnataka	664	3.5
Goa	335	1.8
Total West coast	15745	82.7

Production figures for the eastern coastal States are given below:

	Annual production of cephalopods (t)	% contribution to total cephalopod production of India
Tamil Nadu	2664	13.9
Andhra Pradesh	502	2.6
Orissa	77	0.4
Pondicherry	56	0.3
West Bengal	11	0.1
Total East coast	3310	17.3

Octopod production comes only from Lakshadweep and the annual average was 16t.

Gear-wise production

The average annual production of cephalopods during the three-year period 1982 to 1984 was 18,192 t of which the trawlers contributed 13,127 t (73%). On the same percentage basis, the average annual production of cephalopods by trawlers in India during the subsequent two-year period 1985

and 1986 would be 27,112 t which is double that of the previous 3 year period.

Regarding the traditional gears accounting for 27% of total cephalopod production, data are not available to work out the gear-wise contribution. However, Vizhinjam where there have been no trawler landings and the entire fish production of the centre came from the artisanal sector, the average annual cephalopod production during the five-year period from 1982-83 to 1986-87 was 578 t. The contribution of different gears to the above has been 76.5% by boat seine, 23.3% by hook & line and 0.1% by shore seine. The data show that boat seine is the second most important gear for cephalopod capture and the primary one among the artisanal gears.

Group/species production

Group/species-wise production of cephalopods is not available except for the trawler catch at selected centres. The observations made at the fisheries harbours at Veraval, Bombay, Mangalore, Cochin, Rameswaram, Madras and Visakhapatnam showed that the cuttlefish contributes to 57.2% and squids to 42.8% of total cephalopod landings. Since 73% of the total cephalopod production of the country is by trawlers, the above proportion can be generally used to arrive at the cuttlefish and squid components of total all-India cephalopod production. Accordingly, out of the average annual production of 25,771 t of cephalopods during 1982-1986 period, the cuttlefish were 14 741 t and squids 11,030 t.

Squids: In the class Cephalopoda, order Teuthoidea represent the squids. This order consists of four families, namely Loliginidae, Onychoteuthidae, Ommastrephidae and Thysanoteuthidae. In the presently exploited Indian waters, only the following Loliginid squids are represented: *Loligo duvaucelii*, *L. uyii*, *Loliolus investigatoris*, *Doryteuthis sibogae*, *D. singhalensis* and *Septoteuthis lessoniana*. Of these, *L. duvaucelii* is the most dominant species. *L. uyii* forms an insignificant component (less than a tonne) at Madras. *L.*

investigatoris is caught in small quantities at Madras, Kakinada and Visakhapatnam (together less than a tonne). *D. sibogae* and *D. singhalensis* form a good artisanal fishery at Vizhinjam and also occur in the trawler landings at Visakhapatnam. The fishery for *S. lessoniana* is confined to Palk Bay although recorded from Vizhinjam, Veraval and Lakshadweep. Out of the annual average squid production of 11,030 t, *Sepioteuthis* and *Doryteuthis* together would contribute an estimated 300 t, and *L. duvaucelii* to the rest of 10,730 t, i. e. about 97% of the squid production is by this single species.

Cuttlefish: The taxonomic order Sepiidae (Sub-class Coledidae) is comprised of 2 families namely Sepiidae and Sepiolidae. The latter family is represented by a single species *Enprymna stenodactyla* which occurs as stray catches (not more than about 200 kg/year) at Madras and Proto Novo. Family Sepiidae is the most dominant in the coastal waters and is represented by two genera *Sepia* and *Sepiella*. The cuttlefish species occurring in the fishery with their percentage contribution are as follows: *Sepia aculeata*-52.7%, *S. pharaonis*-37.4%, *S. elliptica*-7.6% *S. brevimana*-0.3%, *S. prashadi*-0.1% and *Sepiella inermis*-1.8%. The occurrence of *Sepia trygonina* and *S. arabica* has been recorded. *Sepia aculeata*, *S. pharaonis* and *Sepiella inermis* are landed in all the maritime States. *sepia elliptica* forms fishery at Veraval and Cochin; *S. brevimana* at Visakhapatnam, Madras and Mandapam and *S prashadi* at Madras.

Catch-per-unit-effort

The proportion of cephalopods in the trawler landings and CPUE at some of the observation centres are given in Table 1. The data would indicate the predominant position of Bombay and Veraval on the north-west coast, Sakthikulangara on the south-west coast, Madras on the south-east coast and Visakhapatnam on the north-east coast for cephalopod production. Both New Ferry Wharf and Sassoon Docks in Bombay emerge as the leading cephalopod landing centres in the country.

TABLE 1

Cephalopod landings by trawlers with catch-per-unit effort at some fisheries harbours (Annual average of 1982-1984).

Centre	Cephalopod component in total trawler landings (%)	CPUE of Cephalopods (kg/trawler-day)
Veraval	4.7	53.8
Bombay New Ferry Wharf	6.7	112.5
Bombay Sassoon Docks	9.2	133.4
Mangalore	2.2	5.3
Cochin	1.0	2.4
Sakthikulangara	4.4	15.2
Rameswaram	1.0	2.4
Mandapam	1.5	2.0
Nagapattinam	1.0	2.4
Cuddalore	2.0	5.7
Madras	4.1	11.0
Kakinada	1.0	3.4
Visakhapatnam	3.1	6.7

Export of cephalopods

The export items of cephalopods include cuttlebone, frozen cuttlefish, frozen cuttlefish fillets, frozen squid and dried squid. The cuttlebone had been exported from very early times and the last 10 years stands at average 26 t. The dried squid is a recent product since 1984.

TABLE 2

Cephalopod production and exports during 1981-1985

Year	Cephalopod landings (t) in India	Cephalopod Products* exported (t)	Approximate landed weight of the exported quantity (t)
1981	9548	2802	4670
1982	15799	3235	5392
1983	18355	4024	6707
1984	20421	3128	5213
1985	31642	7623	12705
Average	19153	4162	6937

*Cuttlebones not included.

Total cephalopod production exported during the five years 1981-85 are given in Table 2. The yield of squids and cuttlefishes is assumed to be an average 60% and the landed weight of exported quantity has been calculated on this basis. It is evident from the data (Table 2) that a large amount of cephalopods landed is under- or unutilised while the domestic consumption is negligible.

SURVEY OF CEPHALOPOD POTENTIAL IN OFFSHORE AND OCEANIC WATERS

One of the major resources projected for exploitation in the Exclusive Economic Zone of India and the adjacent sea is the cephalopods. This has two components, the one on the continental shelf waters (neritic benthic and pelagic) and the other in the oceanic waters. The shelf component would include the additional resources of squids and cuttlefishes that are available in waters beyond the present fishing limits and also increased catches that would result in the event of directed fishing for these species. The oceanic component would comprise the oceanic squids.

Present grounds

As has been seen earlier, the entire cephalopod production of India today comes as by-catch of demersal trawl, boat seine, shore seine and hook & line fishery. In the presently exploited inshore waters upto 50 m depth, there seems to be further scope to increase production of cephalopods. During the last 10 years the cephalopod landings have grown steadily in spite of the slump in overall marine fish production. The annual average cephalopod production increased to 17,740 t during 1981-85 from 12,626 t during 1976-80. The estimated 1986 production was around 43,000 t. Based on the stocks (1978-80 data) estimated at a few centres namely Madras, Cochin and Vizhinjam for the three major species *Loligo duvaucelii*, *Sepia aculeata* and *S. pharaonis*, the projected all-India average annual stock of these species has been given as 56,984 t (Silas *et al.*, 1986).

In the recent years subsequent to the introduction of the high-opening bottom trawl

(HOBOT) at some centres in Tamil Nadu and Gujarat through the extension demonstration of Bay of Bengal Programme and followed up by Central Institute of Fisheries Nautical and Engineering Training in Gujarat, there appears to be a possibility of increasing cephalopod production. In Gujarat, high incidence of squids and cuttlefish was noticed in this new net and in some operations squids formed as high as 24.1% of the catch off Dwarka in the depth range 20-25 fathoms (Swaminath and Vethabothagam, 1987). While the conventional shrimp trawl has hardly 1-1.5m vertical opening, the HOBOT has an opening of 3.5-4.5 m facilitating capture of columnar-fishes.

Squid jigging and stick-held dipnet are two standard cephalopod fishing gears used in the Japanese fisheries for the pelagic squid *Todarodes pacificus*. In India, an experimental programme for testing these gears for the coastal cephalopods, was carried out in 1985 by the Marine Products Export Development Authority with the help of a Japanese expert. The experiments carried out at Cochin and Vizhinjam with manual squid jigging machine and stick-held dipnet on board a 43 ft (13m) vessel yielded a catch rate of 102 squids/hour (Yamasaki, 1985) indicating the technical feasibility of operating such gears in the coastal waters. The work has not, however, been followed up subsequently. If cephalopod production has to show a quantum jump, it is inescapable to introduce fishing methods directed for the squids and cuttlefish.

Offshore resources

The cephalopod resources in the grounds beyond 50 m depth have hardly been touched so far. Pelagic trawling by the erstwhile Pelagic Fisheries Project's vessels off the southwest coast of India and Gulf of Mannar in the seventies has shown considerable concentration of squids and cuttlefishes in the central and southern sectors of the region. The squids formed 4% of the catch in 20-49 m, 34% in 50-80 and 13% in depth beyond 80 m during 1974 between Quilon-Cape Comorin and the Gulf (UNDP/FAO, 1976).

The operations of vessels of the Fishery Survey of India have provided information on the cephalopod resources of the offshore waters. The survey vessels have recorded a catch rate of 20kg/hour of squids and cuttlefish from Wadge Bank and 22 kg/hour from Kerala Coast (Joseph, 1986). The results of operation during October 1981-April 1983 on the Wadge Bank showed an overall cephalopod content of 6.6% of the demersal catch, next only to that of perches (36.3%), Nemipterids (23.8%) and rays (10.1%). *Sepia pharaonis* was the dominant species with 80% composition and *S. aculeata* and *Sepiella inermis* formed stray catches. Among the squids *Loligo duvaucelii* was the important species, with occasional catch of *Sepioteuthis lessoniana*. The depth-wise catch rates showed high density in 10-25 fm (17.5kg/hour), thereafter decreasing progressively to 5.5 kg/hour in 25-40 fm, 3.1 kg/hour in 40-70 fm, 0.7 kg/hour in 70-100 fm and 0.9 kg/hour in 100-125 fm (Joseph *et al.*, 1987). The same authors have estimated the standing stock of cephalopods in the first four depth zones above, respectively, as 952 t, 404 t, 219 t and 30 t totalling to 1605 t for the Wadge Bank as a whole, out of a total fish biomass of 38,330 t. Exploratory data on cephalopods of the east coast are scanty and the available data have shown a poor catch rate of 3 kg/hour (Joseph, 1986).

The foreign trawlers which operated in the recent years under charter in the Indian EEZ, had concentrated on squids and cuttlefish, more particularly on the latter group, besides shrimps and perches. Joseph (1986) reported that the chartered vessels were taking sizeable quantities of squids and cuttlefish ranging from 60-80% of the total catch declared by them. The cephalopod catch rates by some vessels along the west coast were 61.9 kg/hour in the latitudes 7°-9°N, 106.0 kg/hour in 10°-12°N, 76.2 kg/hr in 13°-14°N and 100.6 kg/hr in 16°-17°N. It has also been reported that recently one of the chartered vessels had a catch rate of 106 kg/hr of cephalopods with a total catch of 120 t in the depth range 60-80 m (Joseph, 1986).

M. T. *Murena* which explored the resources of the north-west coast of India during 1977

caught a total of 1015 kg of cephalopods, 761 kg from demersal trawl and 254 kg from pelagic trawl, forming 0.2% of total fish catch of the vessel on its survey. The major species were *Sepia aculeata*, *S. pharaonis* and *Loligo duvaucelii*. The catch rates in demersal trawl were 2.14 kg, 1.73 kg and 1.50 kg per hour from depth zones 55-90, 91-125 and 126-360 m respectively (Bapat *et al.*, 1982). The pelagic catch was the highest in the depth 55-90 m.

Since 1985, the Fishery and Oceanographic Research Vessel *Sagar Sampada* has carried out fishery resources survey in the EEZ of India. The operations were in the depth zone of 50-200 m with a few exceptions of deep water trawling. *Sepia pharaonis* and *Loligo duvaucelii* were the dominant species. The stations where the cephalopod component was more than 40% of the catch with the depth are given below:

	Position	Depth (m)	Dominant Species
<i>West Coast</i>			
1.	08°43'N 76°10'E	80	<i>S. pharaonis</i>
2.	11°40'N 74°56'E	63	..
3.	12°22'N 74°26'E	127	..
4.	13°51'N 73°17'E	213	..
5.	14°31'N 73°24'E	101	..
6.	15°02'N 73°34'E	58	<i>L. duvaucelii</i>
7.	15°30'N 73°15'E	70	<i>S. pharaonis</i>
8.	18°01'N 71°37'E	93	..
9.	18°58'N 71°02'E	86	<i>S. pharaonis</i> and <i>L. duvaucelii</i>
10.	21°26'N 68°58'E	70	<i>S. pharaonis</i> and <i>S. trygonina</i>
<i>East Coast</i>			
11.	10°35.7'N 80°11.02'E	72	<i>L. duvaucelii</i>

The exploratory and commercial data presented above would indicate that, as in the case of inshore waters, the offshore areas between depth 50-200 m off the west coast have much greater resources of cephalopods than those of the east coast.

Oceanic resources

The data available on oceanic squid resources around India are qualitative and indicative of a vast potential. The information is from the surveys of research vessels of India as well as of other countries which worked in the Arabian sea and Bay of Bengal on international programmes. R. V. *Varuna* of the erstwhile Indo - Norwegian Project which worked on the programmes of the Central Marine Fisheries Research Institute brought out the early direct information on the occurrence and abundance of oceanic squids in Lakshadweep Sea and south-eastern Arabian Sea (Silas, 1969). The occurrence of the Ommastrephid squid *Symplectoteuthis oualaniensis* in the Indian waters was highlighted in the above work. Filippova (1968) reported the occurrence of several species of oceanic squids in the Indian Ocean with their distributional range. *S. oualaniensis* inhabits tropical waters up to 20°S. Further south, it is replaced by *Ommastrephes bartrami* and *Todarodes sagittatus angolensis* up to 37°S.

R. V. *Shoyo Maru* of the Japanese Fishery Agency, in co-operation with IOP and FAO, carried out surveys of the North Arabian Sea off Pakistan and Central part of the south Arabian Sea during 1975-77 (Fishery Agency of Japan, 1976, 1977). The vessel gave special attention to the distribution and behaviour of the oceanic squid *S. oualaniensis* in the area by acoustic survey and sampling by hand-lines. Dense echo records of the squid in the offshore waters of 200 m depth or more were received by the vessel. The squids caught ranged 17.4-48.8cm in mantle length, the largest weighing about 4 kg.

In 1986, a single specimen of *S. oualaniensis* of 43.4 cm mantle length and 2.46 kg weight was caught in drift gill net at a depth of 80 m off Mangrol in Gujarat (Raje, pers. comm.)

FORV *Sagar Sampada* has recently caught *S. oualaniensis* during her survey in the Indian EEZ. The squid in large numbers have been observed on many occasions congregating around the vessel in the night, attracted by her lights. Since the vessel is not equipped

for squid fishing, the squids could not be caught except on rare occasions by handline. However, on her cruise No. 22 in October, 1986, the vessel caught about 700 oceanic squids in 10 Pelagic/midwater hauls, along with mesopelagic fishes, off the north west coast of India (Lat. 18°-22°N, Long 64°-69° E). The squids were caught in trawling depth of 40-250 m and bottom depth of 2496-3444m. The squids measured 6.5-47.2 cm in mantle length and the largest weighed 3.5 kg. Clear indications of availability of oceanic squids in the Indian EEZ have thus become available.

POTENTIAL ESTIMATES

Voss (1973) estimated the cephalopod potential of Indian Ocean region at 500,000t. George *et al.* (1977) estimated the potential for Indian EEZ to be around 180,000 t of which 55% is to come from the upper east coast, 11% each from lower east coast and north-west coast and 20% from the south-west coast. Recently Chikuni (1983) estimated the potential of Indo-Pacific region to be about 1.1 to 1.4 million tonnes as against a catch of 0.3 million tonnes. His estimates for Bay of Bengal and Eastern Arabian Sea respectively are 50,000-100,000 t and 100,000-150,000 t. Silas (1986) considered Chikuni's (1983) estimates too low for the area as compared to the estimates for the neighbouring regions such as the Yellow Sea, East China Sea and South China Sea. Silas (1986) estimated India's potential harvest by 2000 A. D. by small scale neritic sector at 50,000 t and oceanic sector at 25,000-50,000 t.

RESEARCH & DEVELOPMENT NEEDS

The cephalopod production in India has shown a steady growth since the exports began in 1973. However, considering the potential of the resources as well as demand for export, India can do much better.

On a global scale cephalopods accounted for an annual average of 1.60 million t during 1981-82. The percentage contribution has ranged from 2.1-5% of total world marine fish production. The squids with 1.16g million t

contributed to 72.22% total cephalopod production, followed by cuttlefishes (232,000t and 14.52%) and Octopus (212,000 t and 13.26). The major cephalopod fishing areas in the world are in the North West Pacific (Japan, ROK, China, Taiwan, USSR), Central East Atlantic (Western Africa), North West Atlantic (Canada), Mediterranean (Spain, Italy), South West Pacific (New Zealand), South West Atlantic (Latin America) and Central East Pacific (U. S. A., California) (Worms, 1983). The most dynamic cephalopod fishery in the world exists in Japan with an annual average production of 577,866 t (1982-85 period), of which squids formed 90.4%, cuttlefish 2.3% and octopus 7.3%. Republic of Korea with 175,508 t and Spain with 104,552 t are behind Japan. The cephalopod fisheries are carried out on an industrial or semi-industrial scale in Japan, Korea, Canada, U. S. A. (California), Italy and Spain and in other countries the fishery is of a very local food character (Worms, 1983). Distant Water fishing fleets of Japan, Korea, Spain and U. S. S. R. operate in several important cephalopod fishing grounds of the world and, in fact, the development is due to such fishing activities under licensing arrangements or joint ventures.

In India, it has been very well realised that cephalopods are one of the resources of future but very little has been done to improve the fishery. The increase in landings reaching the order of 40,000 t in 1986-87 is not due to any specific development programme but a natural increase in the bye-catches of the trawlers and other artisanal gear. The only attempt that has been made was the experimental fishing carried out by the Marine Products Export Development Authority in 1985 which has not been followed up so far. A squid jigging vessel which has been in India for the last several years has not carried out any work on this line for want of expertise and for having fixed the priority to tuna long lining over squid jigging, as it is a combination vessel. Recently some interest in developing the octopus fishery in Lakhadweep was evinced but it was soon realised that the resource is very limited for taking up any worthwhile programme in the lagoons of the islands. Thus India is yet to make a beginning towards exploitation of

cephalopods on modern lines and on an industrial basis.

Silas (1986) has elaborately dealt with the perspectives, priorities and targets for 2000 A.D. with regard to cephalopod resources of India. The potential harvest by 2000 A. D. has been given as 50,000 t from the small-scale fisheries operating in the neritic regime and 25,000-50,000 t of oceanic squids from the oceanic regime. The inshore production through bye-catch has, after the above article was written, already reached the order of 32,000 t in 1985 and 43,000 t in 1986. There have been no landings of cephalopods from the 50-200 m depth zone. This zone has good cuttlefish potential as has been shown by the operation of chartered vessels early this decade, although accurate data on these resources and grounds have not been made available. It stands to reason, therefore, that the neritic potential can be much higher than the 50,000 t projected by Silas (1986).

With regard to the oceanic squid resources it remains open until systematic surveys are carried out in the EEZ. The results of FORV *Sagar Sampada* referred to earlier are still indicative, perhaps a slight improvement over the acoustic results given by R. V. *Shoyo Maru* (Fishery Agency of Japan, 1976, 1977) and the earlier data of R. V. *Varuna* (Silas, 1969) and the U. S. S. R. survey vessels (Filippova, 1968). Systematic quantitative data on oceanic squid resources can come only from survey by vessels rigged for appropriate light fishing with automatic jigging gear. Both Australia and New Zealand had arrangement with Japan for exploring their cephalopod resources upon which New Zealand has developed a successful squid fishery. West African States and Canada had to enter into arrangements with industrial squid fishing countries for developing their cephalopod fishery.

India has the institutional framework for undertaking a major programme on cephalopod research and development. It would need outside technical assistance initially to launch a meaningful programme. Within the country, there is need for an unified approach. This can be achieved only through a well-planned

mission-oriented cooperative R & D programme among the agencies now engaged in cephalopod work. In such a programme the Fishery Survey of India, the Marine Products Export Development Authority, the Central Institute of Fisheries Technology and the Central Marine Fisheries Research Institute should be represented under a single line of leadership. The resources from each of these organisations may be pooled and augmented to the necessary extent. This will be an experiment in the fisheries sector and if it works well the concept could be extended to other major resources.

REFERENCES

- BAPAT, S. V., V. M. DESHMUKH, B. KRISHNA-MURTY, C. MUTHIAH, P. V. KAGWADE, C. P. RAMAMIRTHAM, K. J. MATHEW, S. KRISHNA PILLAI AND C. MUKUNDAN 1982. Fishery resources of the Exclusive Economic Zone of the North West Coast of India. *Bull. Cent. Mar. Fish. Res. Inst.*, 33: 86 pp.
- CHIKUNI, S. 1983. Cephalopod resources in the Indo-Pacific Region. In: Caddy, J. F. (ed.) *Advances in assessment of world cephalopod resources. FAO Fish. Tech. Pap.*, (231): 264-305.
- FILIPPOVA, J. A. 1968. New data on the cephalopods of the Indian Ocean. *Proc. Symp. Mollusca, Mar. biol. Ass. India Pt 1*: 257-264.
- FISHERY AGENCY OF JAPAN 1976. Report on cruise of the R. V. SHOYO MARU in the north Arabian Sea Survey, in co-operation with IOP, FAO to assess the pelagic fish stocks, 2 October 1975-14 January 1976. *Res. Dev. Div., Fish. Agen. Japan*, 110 pp.
- FISHERY AGENCY OF JAPAN 1977. Report on cruise of the R. V. SHOYO MARU in the North Arabian Sea Survey, in co-operation with IOP, FAO to assess the pelagic fish stocks, 2 October 1976-13 January 1977. *Res. Dev. Div., Fish. Agen. Japan*, 165 pp.
- GEORGE, P. C., B. T. ANTONY RAJA AND K. C. GEORGE 1977. Fishery resources of Indian Economic Zone. *Silver Jubilee Souvenir, Integ. Fish. Proj.*, October 1977: 79-116.
- HORNELL, J. 1950. Fishing in many waters. Chapter XV. Fishing for *Octopus*, cuttlefish and squid. *Cambridge Univ. Press. Cambridge*, 130-135.
- JOSEPH, K. M. 1986. Some observations on potential fishery resources from the Indian Exclusive Economic Zone (EEZ). *Bull. Fish. Surv. India.*, No. 14 : 1-20.
- JOSEPH, K. M., P. SULOCHANAN, M. E. JOHN, V. S. SOMAVANSHI, K. N. V. NAIR AND ANTONY JOSEPH 1987. Demersal fishery resources of Wadge Bank. *Bull. Fish. Surv. India*. No. 12 : 52 pp.
- MPEDA. 1987. Statistics of marine products exports, 1985 *The Marine Products Export Development Authority, Cochin*: 263 pp.
- RAO, K. VIRABHADRA 1954. Biology and fishery of the Palk-Bay squid *Sepioteuthis arctipinnis* Gould. *Indian. J. Fish.*, 1 : 37-66.
- SILAS, E. G. 1969. Exploratory fishing by R. V. VARUNA. *Bull. Cent. Mar. Fish. Res. Inst.*, 12 : 86 pp.
- SILAS, E. G. 1986. Cephalopod Resources: Perspectives, priorities and targets for 2000 A. D. In : (E. G. Silas Ed.) *Cephalopod bionomics, fisheries and resources of the Exclusive Economic Zone of India*, *Bull. Cent. Mar. Fish. Res. Inst.*, 37 : 172-183.
- SILAS, E. G., M. M. MEIYAPPAN, R. SARVESAN, K. PRABHAKARAN NAIR, M. SRINATH AND K. SATYANARAYANA RAO 1986. Stock Assessment: Squids and cuttlefishes at selected centres. In: (E. G. Silas Ed.) *Cephalopod bionomics fisheries and resources of the Exclusive Economic Zone of India*. *Bull. Cent. Mar. Fish. Res. Inst.*, 37 : 71-79.

- SWAMINATH, M AND P.K. VETHABOTHAGAM 1987. Transfer of technology in diversified fishing-a successful Gujarat story. *CIFNETIBULIO4/DFT* : 56 pp.
- UNDP/FAO 1976. results 1973/74. *UNDP/FAO Pelagic Fishery Project Progress Report No. 12*, 116 pp.
- VOSS, G. L. 1973 Cephalopod resources of the world. *FAO Fish. Circ.* (149): 75 pp.
- WORMS, J. 1983. World fisheries for Cephalopods: A synoptic overview *In: Caddy, J. F. (ed.), Advances in assessment of world cephalopod resources. FAO Fish. Tech. Pap.*, (231) : 1-20.
- YAMASAKI, MAKOTO 1985. Report on demonstration-cum-training in squid jigging, and dip-net fishing. *The Marine Products Export Development Authority, Cochin* : 107 pp.

NEW TRENDS IN THE TRADITIONAL MARINE FISHERIES AT TUTICORIN

P. Sam Bennet and G. Arumugam
Central Marine Fisheries Research Institute, Cochin

ABSTRACT

Quiet changes have taken place during recent years in the fishery by traditional crafts and gear at Tuticorin. This study refers to the changes taken place in the commercial fisheries of Tuticorin due to the introduction of mechanisation of traditional fishing crafts. Started in 1985 over 90 Tuticorin type boats have been fitted with inboard engines of 10 HP mainly of the Kengaroo make. These boats operate drift nets and hook & lines for demersal as well as pelagic species of fish. Data collected two years prior and two years after the introduction of mechanisation of indigenous crafts have been compared. Operational parameters and benefits of mechanisation are discussed. The fishermen are benefitted by increased catch per unit as well as increased price for the catch by arriving earlier.

During the past two decades revolutionary changes have taken place in the craft and gear employed in the coastal indigenous fisheries. An important ingredient in the craft development in indigenous fisheries was the introduction of mechanisation on a large scale with the financial support of Governmental agencies in the 1960s. Encouraged by the Government many small scale fishermen took up mechanisation of craft. However, this has developed into industrialization of lucrative pelagic and demersal fisheries benefitting few people who could operate large fishing boats. Small scale and indigenous fishermen were left in the same old state with their traditional methods of fishing. Artisanal fishermen have withstood the onslaught by large scale mechanization of fishing operations and have rallied round in recent years to introduce power to their traditional crafts. This study deals with the introduction of machines to traditional craft employed at Tuticorin with inboard engines and is confined to observations spread over a period of four years from 1983 to 1986. The impact of introduction of engines to traditional crafts are brought out and discussed.

TRADITIONAL FISHING CRAFT OF TUTICORIN

A large number of people are engaged in small scale fishing at Tuticorin using traditional plank built boat called Tuticorin type boat. A total of 360 Tuticorin type boats were in use during 1983, the number has increased to 431 in 1984; 458 in 1985 and

472 in 1986. Boats of three sizes namely 8.6 metres, 9.0 m and 9.5 m were in use. Detailed description of Tuticorin type boat is given by Chacko and Rajendren (1955). These boats are highly efficient all weather crafts and the introduction of machines for propulsion has enhanced considerably their range of operation.

**MECHANISATION OF TRADITIONAL
FISHING CRAFT**

Adequate berthing and landing facilities are available in the region by way of fishing harbour for larger mechanised fishing craft. On the other hand, smaller craft operating indigenous gear are landed on the beach itself. Hence the engines for propulsion fitted on the indigenous crafts are suited in such a way that they are kept safe inside the boats or taken home for repairs and safe keeping when not in use. Traditional fishery is labour intensive and spread all along the coast. It forms the principal production means of the fisheries of the Tuticorin area and remained a dominant small scale industry. Faced by the demand for shrimp in international market many of the once traditional fishermen became private industrial fishermen operating large mechanised crafts and gears suited to fish mainly shrimp. There was popular fear that the industrialised and highly organised mechanised sector was likely to wither out the traditional sector in course of time (Bapat and Kurian, 1978). On the contrary the traditional sector also strengthened itself and adapted to the changing times by introducing inboard and outboard engine propellants to the fishing crafts. The Tuticorin type boats are suited for fitting machines and gradually many boats have been fitted with inboard engines with least modification in the boats.

**TYPE OF ENGINES FITTED IN
TUTICORIN TYPE BOATS**

Many manufacturing firms have come forward to provide engines suitable for the traditional crafts. Substantial loans are also given by three nationalised banks to purchase and install marine engines on the boats. During the two years 1985 and 1986 about 90 Tuticorin type boats have been fitted with engines. The major constraint was in the case of joint ownership where in one or the other owner was unable to pay his share. Table 1 shows the type of engines used in Tuticorin type boats. The Kangaroo vertical type engine is most popular with boat owners at Tuticorin. On the whole it is easy to purchase a marine engine suitable for one's taste and easier to install and operate.

TABLE 1

Types of engines fitted in Tuticorin type boats

Name of engine	Coolant	Horse power	Price (approx) in Rupees
Sakthi	Air	9 (8.8)	7500
Lambedi	Air	9	7500
Kangaroo	Water	8, 10	6500
Field master	Water	8	5300
Kirloskar	Water	8	6500
H. T. C.	Water	8	5500
Indo western	Water and air	10	6000
International	Water	10	7300

Average cost of each Tuticorin type boat fitted with inboard engine comes approximately to Rs. 44000 (including cost of boat Rs. 30000; price of engine Rs. 7000 and charges for fitting the engine Rs. 7000). Fishing operations are carried out with drift nets and hook & line costing around Rs. 40000. Normally the boats fitted with engines go for fishing around 15.00 hours and return next morning by 7.00 hrs. They carry a complement of three fishermen and go to a distance of 20 to 30 miles. On the contrary, traditional fishermen using boats without engine leave for fishing between 13.00 and 15.00 hrs and come back next day around 8.00 to 12.00 depending on the direction and strength of the wind. They carry five people and fish in the 20 mile area.

CATCH AND EFFORT

Data for two years preceding the introduction of machines on Tuticorin type boats and for two years of operation with mechanised boats were considered. Contribution of non-mechanised Tuticorin type boats with drift nets and hook & lines from 1983 to 1986 and mechanised Tuticorin type boats with driftnets and hook & lines from 1985 to 1986 were compared Table 2.

During 1983 a total of 4142 drift net units were operated from non-mechanised boats landing 364.2 t of fish. The catch-per-unit being 87.9 kg of fish. Hook & line boats during the year operated 11530 units landing

TABLE - 2.

Comparative statement of catch, units operated and catch per unit by indigenous boats using drift nets and hook & line during 1983 to 1986.

Year	Drift net			Non-mechanised units Hook & line			mechanised units Drift net			Hook & line		
	Catch kg.	Units operated	Catch per unit kg.	catch kg.	units operated	catch per unit kg.	catch kg.	units operated	catch per unit kg.	catch kg.	units operated	catch per unit kg.
1983	364283	4142	87.9	832212	11530	72.2	Not operated					
1984	447456	4790	93.4	1023780	13615	75.2	Not operated					
1985	297650	3598	82.7	750480	10076	73.5	274798	2833	96.9	435957	4898	89.1
1986	68853	1124	61.2	303788	5460	55.6	155452	2486	62.5	724887	10091	71.8

832.2 t with the catch-per-unit at 72.2 kg. In 1984 a total of 447.4 t of fish were landed by 4790 drift net units with the catch-per-unit of 93.4 kg. The hook & line fishery during 1984 recorded an annual catch of 1023.7 t of fish from 13615 units and the catch-per-unit during the year was at 75.2 kg.

During 1985 both non-mechanised and mechanised Tuticorin type boats were operated in the traditional sector. Total landings by non-mechanised drift nets came to 297.6 t by 3598 units. The catch per unit being 82.7 kg. Hooks & line during 1985 landed 750.4 t of fish by 10076 units with the catch rate of 73.4 kg. mechanised Tuticorin type boats operated both drift nets and hook and & lines during 1985. Total drift net units operated came to 2833, landing 274.7 t of fish. The catch per unit was 96.9 kg. During 1985 hook & line units numbering 4898 were operated from mechanised boats. Total catch came to 435.9 t with the catch per unit at 89.1 kg.

In 1986 there were 1124 non-mechanised drift net units operated at Tuticorin, landing 68.8 t of fish with the catch per unit rate of 61.3 kg. During the year 5460 hook & line units were operated from non-mechanised boats landing 303.7 t of fish. The catch per unit during the year was 55.6 kg. Mechanised boats during 1986 operated a total of 2486 drift net units landing 155.4 t of fish and the catch per unit was 62.5 kg. Total fish landed by 10091 mechanised hook & line units in 1986 was 724.8 t with the catch per unit at 71.8 kg.

Catch per unit equivalent to catch per day's fishing was used as an index of fishing success. A general decline in catch per unit was noticed in the 1986 fishery. A comparative observation between non-mechanised and mechanised units show a definite increase in the catch per unit by mechanised boats during 1985 and 1986 two years of introduction of mechanised units in the traditional sector (Table 2).

SPECIES COMPOSITION

The non-mechanised and mechanised Tuticorin type boats tend to fish in the same areas at different times of the year and the fishing conditions are also similar. The principal components of the drift net catch were seer-fish, carangids, tuna, perches barracuda and sharks, perches from the most important component of the hook & line catches followed by nemipterids, seer, fish, sharks and carangids. No conspicuous changes in species composition are evident between the craft. Furthermore, the various species are equally vulnerable to different gears irrespective of the type of craft used. Because of the longer stay in the fishing ground catch by the mechanised boats are proportionately more than that of non-mechanised boats.

REMARKS

The traditional fishermen operating indigenous crafts and gears along the Tuticorin coast have been greatly benefitted by

mechanisation of Tuticorin type boat. The results achieved over a period of two years are encouraging. Benefits of introduction of motor to traditional crafts are much. Especially important is the time saved in reaching the fishing ground and returning to shore. Vagaries of wind and current have been overcome to a large extent and the fish reaches to the market in time to fetch higher price.

There is a fairly well established traditional system of fishing along the Tuticorin coast with indigenous Tuticorin type boat as the principal craft. Socio-economic conditions have placed the traditional sector on a lower footing than the fully mechanised industrial sector. A significant improvement in the socio-economic structure of the traditional sector is the creation of mechanisation to the existing crafts. Though it is partial mechanisation in its true sense the fitting of motor to the boat added new dimension in the exploitation of nearshore fishery resources.

It is not yet possible to say for certain whether there is any wastage in fuel or man power in operating mechanised boat. Many of the boats switch over to sail when the wind is favourable. Number of persons on fishing trips have been reduced to three from the normal compliment of five in non-mechanised Tuticorin type boats. Reduction in fishing hand is not a common feature as many of the boats are family owned and able bodied family

members go for fishing irrespective of the need. The earnestness with which motors are fitted on to the existing boats is itself an indication of the apparent benefits. This rapidly increasing trend is likely to extend the fishing grounds and bring in more fish for the consumers.

ACKNOWLEDGEMENTS

The authors are thankful to Dr. P. S. B. R. James Director, Central Marine Fisheries Research Institute for the encouragement and guidance given to them in this study.

REFERENCES

- BAPAT, S. V. AND A. KURIAN 1978. Present status and role of small-scale fisheries of India. Issued on the occasion of the *Seminar on the Role of Small-scale Fisheries and Coastal Aquaculture in Integrated Rural Development*; Madras.
- CHACKO, P. I. AND A.D.I. RAJENDRAN. 1955. A survey of the fishing industry of Tuticorin, Gulf of Mannar. *Madras Fisheries Year Book*, VIII; 175-193.
- GEORGE, M. S. 1978 Role of small - scale fisheries in Karnataka and its impact on rural economy. Issued on the occasion of the *Seminar on the Role of Small-scale Fisheries and Coastal Aquaculture in Integrated Rural Development*; Madras.

CONSERVATION OF MARINE FISH GENETIC RESOURCES—PRESENT STATUS AND ACTION NEEDED

P. Das, P. C. Mahanta and D. Kapoor
National Bureau of Fish Genetic Resources, Allahabad - 211 004, U. P.

ABSTRACT

Overfishing, unscientific commercial exploitation, and destruction of habitats caused by nature and also induced by man have been, of late, causing serious threat to the marine fish germplasm resources. Judicious exploitation, protection for improvement and conservation are, thus, required for keeping the natural resources truly renewable.

Conservation approaches are in situ, ex situ, entire biomass or flexible mix with the responsibilities required to be equally shared by the professional personnel, policy makers and the people themselves. Top priority may be given for conservation of endangered species for maintaining genetic variability to maximize probability of their long term survival.

The present status of knowledge about resource conservation has been outlined in the paper with mention about the present Indian strategy for the research on the subject. This broadly includes a thorough survey of fish fauna, cataloguing of genotypes, study of genetic variability, scanning of polymorphic characters, development of practicable methodologies for conservation of exploited and endangered species and implementation of the same through concerned agencies.

INTRODUCTION

Many of the conventional fishing grounds identified and charted in the seas during periods of early exploration and also the feeding and breeding grounds of fishes have undergone changes due to various reasons like increased fishing pressures, pollution and environmental changes. Migratory varieties are also subjected to pressure of diversion of flowing waters, artificial barriers and have been found to adjust to changes by restricting their sojourn to lower reaches of estuaries or become endemic. Sedimentation and siltation from land sources also have been altering the ecosystems. Overfishing and unscientific commercial exploitation of some species or in some fishing grounds leading to depletion of the fishery have aggravated the situation in the country. Some of the species, as a result of all those factors, are probably even endangered.

Domestication of species and induced genetic manipulations of selected species are, at the same time, continuously interfering with the links of co-evolution. Such interferences are likely to be intensified with the advancement of knowledge and applicability of genetic technologies.

It is thus necessary to remain vigilant on the changes that have been taking place in the marine environment and adopt conservancy measures, according to requirement of a particular situation in order to keep the fish germplasm resources truly renewable.

GENETIC VARIABILITY OF FISHES

Genetic variation is the means by which a species adapts to changes in its environment. New genetic variation arises in a population from either spontaneous mutation of a gene or by immigration from a population of genetically different individuals. The number of relative abundance of alleles in a population is a measure of genetic variation or heterozygosity. Owing to various reasons, as indicated in the foregoing paragraphs the existing genetic variability is feared to be under threat of extinction, Particularly in some cases.

Assessment of fish germplasm resources - present status

Fish genetic studies has, so far, been largely restricted to elaborate chromosomal studies of different species in the country.

For any broad programme of conservation of fish genetic resources, survey is the foremost requirement which is yet to be geared up to its desired extent. There is a general need for identifying important biogeographic areas, species and their distribution in order to provide background on the preservation of resources of exploited and potentially threatened species (Jhingran & Gupta, 1986) which is yet to be accomplished.

A thorough taxonomic and ecological survey of fish species occurring in each area and a full checklist of these species indicating a status of each and its significance in terms of ecological, economic, scientific and social terms are basic needs, which also are yet to be achieved in India.

There is dearth of information on the genetic differentiations within most of the naturally occurring species and the quantitative estimates of the magnitude and relative importance at various levels of organization. This is a significant gap from the standpoint of resource conservation and efficient use of existing variation.

A quantitative estimate of the absolute and relative importance of various sources of variation constituting the total gene diversity is yet to be studied hierarchially *i. e.* within and between populations by collecting samples from areas of different ecosystems and multiple locations within each ecosystem on different forms over a large geographical range.

Morphological, meristic, cytotoxic and electrophoretic studies are yet to be undertaken to survey exploited species to determine specific indicators of distinct populations within each species by unique phenotypes, degrees of asymmetry in karyotypes or gene frequencies. Correlations between these will resolve the soundness of the method which gives unbiased estimate of genetic variations (Jhingran and Gupta, 1986).

Analytical approach to resource protection

In the past, regulations based on empirical knowledge were imposed to cater to maximum sustainable yield. These regulations assumed the forms of protective legislations of mesh

limit, legal sizes, closed season, declaration of sanctuaries, limit on catches, restriction on effort, prohibition of use of destructive methods of fishing etc.

Research in the last few decades has given rise to an analytical approach in contrast with the above empirically determined methods. The analytical approach seeks to investigate the causes of change in the population size and yield so that these are analysed first into separate components and synthesized ultimately into formulations or mathematical models determining the means of obtaining the optimum yields, (Jhingran, 1985).

Resource conservation approaches

Conservation methodologies for marine fisheries resources can take the following 3 possible forms (Das *et al.*, 1986).

(a) *In-situ* preservation of land races and wild relatives where genetic diversity exists and where wild forms are present. This can be done through their maintenance within natural or man-made ecosystems in which they occur. The major advantages of *in situ* conservation are (i) continued coevolution. In the wild, these species can continue to coevolve with other forms providing the breeder with a dynamic source of resistance that is lost *in-vitro* conservation (ii) maintenance of *in situ* conservation permits the breeder to study its auto-ecology and to obtain data that can assist in the selection of germplasm that might otherwise be overlooked (iii) natural parks and biosphere reserves may provide less expensive protection for the wild relatives of fishes than *in-vitro* measures.

(b) *In-vitro* conservation can be done outside their natural habitats either perpetuating sample population in genetic resources centre or in the form of gene pools of gamete storage, germplasm banks etc. The seed or *in-vitro* cell lines are stored in gene banks under appropriate conditions for long-term storage. While this is the mode for preservation of most plant and animal genetic resources, the technique is yet to be adopted for fish gamete conservation.

(c) *Entire biomass*- This implies the entire preservation of animals and plants in a biomass.

The National Marine Parks which are being established in Lakshadweep, areas of Palk Bay and Kutch are in the lines of entire biomass conservation. This type of preservation will be extremely important in slowing the rate of species extinction (Swaminathan, 1983).

(d) *Flexible mix of methods*- In view of some problems in the different approaches, flexible mix of various methods may be necessary in particular situations.

Conservation genetics of endangered fishes

Management of endangered fishes is yet to fully incorporate conservation genetics into recovery programmes. Genetic aspects of small populations must be considered at the outset of management programmes in order to maximize probability of their long-term survival and continued adaptability. Total genetic variance of a species consists of within population genetic diversity, and the differences found among populations. Both types of variance should be maintained to maximize adaptive flexibility of endangered fishes.

Forces that erode genetic variation include small population size, population bottlenecks, genetic drift, inbreeding depression, artificial selection in captivity, and mixing of distinct genetic stocks. These can lead to increased homozygosity, loss of quantitative variation, and exposure of deleterious recessive alleles, all of which may reduce fitness.

Suggestions for genetically sound management of endangered fishes include genetic monitoring of natural and captive populations, use of large numbers for captive breeding where feasible, selective mating to avoid inbreeding where necessary, minimization of time in captivity and separate maintenance of distinct stocks (Meffe, 1986).

Classified spheres of responsibilities

Three major types of responsibilities for resource conservation can be discussed as follows, based on the action needed. (a) The professional responsibility has to be discharged by geneticists, fish breeders, ecologists, conservationists and a whole series of scientists and

technologists connected with the identification, collection, conservation and utilization of genetic variability. (b) The political aspects of the problem relates to the development of national policies which will help to accord priority to the protection of the environment, conservation of genetic material, and appreciation of the dangers arising from genetic erosion and vulnerability and the consequent need to provide enough financial and technical resources to all work related to conservation. (c) Even if the necessary professional skill and political will are available, the cause of conservation can go astray if there is no widespread awareness among the general public on the need to promote development without destruction and of the pivotal role the people themselves can play in genetic conservation.

Present strategy of resource conservation

Though the need to conserve animal and forest resources was taught and decreed in parts of China and India as far back as 700 B. C., the fish genetic resource conservation on modern lines is a very young concept and recent venture in the country. This is being implemented through the newly established research organisation which has come to be known as the National Bureau of Fish Genetic Resources. The identified immediate priorities and main thrusts for the task include (i) ecological and taxonomic surveys of natural habitats to identify genetically distinct populations with the help of advanced techniques, (ii) cataloguing of the genotypes, (iii) collection of information on genetic variability for suggesting steps for conservation of genetic diversity, (iv) ascertaining the characters that are polymorphic in nature for inclusion in studies of genetic resources and (v) development of practicable methodologies for conservation of the exploited and endangered species under Indian conditions.

Future additional strategies of conservation

With the advent of new techniques for genetic manipulation and analysis of biological functions, it may be possible in future as already demonstrated in some cases of animals and plants, to tailor make genes for the hyper expression of functions of desired traits in fishes also. It can be visualised that cassettes of DNA

clones carrying useful genes in forms for their maximal expression will be constructed. Prior to a detailed molecular analysis of fish genetics and application of genetic technology, preservation of specific genetic traits is necessary to provide most of the material for DNA analysis.

In view of the enormous quantitative and qualitative dimensions of the problem of conservation, it is obvious that efforts will have to be selective. It thus need be directed towards more realistic approach in view of our limitations in the country and the same should meet our immediate requirements.

REFERENCES

- DAS, P. C. MAHANTA AND D. KAPOOR. 1986. Genetic Improvement of Fish Stock and Resource Conservation. *NBFGR Bulletin No. 1*, 1986.
- JHINGRAN, A. G AND R. A. CUPTA, 1986. Objectives and methods of assessing exploited fish genetic resources. (Abstr.) *Symposium on Conservation and Management of Fish Genetic Resources of India*. National Bureau of Fish Genetic Resources, Allahabad.
- JHINGRAN, V.G. 1985. *Fish & Fisheries of India*. Revised edition. Hindustan Publishing Corporation (India), 6 U. B. Jawahar Nagar, New Delhi.
- MEFFE, G. K., 1986. Conservation Genetics and the Management of Endangered Fishes. *Fisheries*. 11, No. 1 : 14-22 pp.
- SWAMINATHAN, M. S. 1933. Genetic conservation: Microbes to man. Presidential Address XV International Congress of Genetic. New Delhi, 32 p.

THE ROLE OF PLANKTON RESEARCH IN FISHERIES DEVELOPMENT

T. Balachandran and K. J Peter

National Institute of Oceanography, Regional Centre, Cochin 682 018

ABSTRACT

A survey of literature reveals the large-scale investigations carried out to assess the quantum of fish resources that can be harvested from the sea. However, the answer to the basic question concerned with what makes some species of fish superabundant in the oceans remains unanswered. Recent studies on the associations between the plankton community and fisheries illustrate how the biological oceanographic data may be utilized in understanding the mechanisms contributing to the survival of fish. Many authors have indicated clearly defined relationships between the environmental parameters and the fishery. In this paper an attempt is made to assess the role of plankton that can contribute towards fisheries development.

Studies on Indian Ocean plankton based on I. I. O. E. material showed that the most important factor that influences the fisheries of a region is the nature and extent of plankton production because of the fact that the survival of fish and fish larvae in a locality is dependent on the type and availability of food. The period of successful fishery, especially the plankton feeders such as mackerel and sardine, have been found coinciding with the period of good plankton production. Thus the survival-density dependence at larval stages in terms of the amount of feed per organism may play a determinant role. The question to be considered is whether fish larvae are too dilute or not to affect the density of their food organisms. It can be concluded that fish larvae are probably too dilute during the early phases to affect their food but as larvae grow this tendency is reversed, and food becomes a limiting factor. However, the production food organisms relative to fish feeding is largely a density independent process.

INTRODUCTION

The International Indian Ocean Expedition surveyed Indian Ocean during 1961-'65, the Research Vessel *Varuna* during 1961-'70 surveyed the south-west coast of India including Lakshadweep Seas and the UNDP/FAO Pelagic Fishery Project surveyed the southwest coast of India during 1971-1975. The main objective of these surveys was to determine accurately and precisely the distribution and abundance over space and time, of plankton with emphasis on Ichthyoplankton. These data can be of use in the prediction and quantitative evaluation and potential fertile fishery grounds and management of the presently exploited and future fisheries. Plankton biomass is considered as an index of fertility of the oceans. Also they are important as they form the base of the food web upon which larger organisms including fishes ultimately depend. It is the nature of plankton community that determines or controls the fish population of that area. Thus the effective plankton cum ichthyoplankton surveys can help us to

determine- 1) spawning areas and seasons, 2) biomass of adult spawners, 3) annual fluctuations in adult biomass, 4) migrations of adults, 5) growth and mortality of larval stages, 6) Relation of oceanographic conditions to distribution and abundance of both adults and larvae, 7) trophic relations among fish larvae and zooplankton and 8) species interactions during the larval stage that may subsequently affect stock size.

ZOOGEOGRAPHY

The first stage necessary, to achieve the above objectives, is to obtain the necessary basic knowledge on the taxonomy and then on the distribution and ecology of the different components of the planktonic community. Hundreds of publications have come out on the above lines. To mention a few among them are IOE collected reprints 1965-'72 by UNESCO, UNDP/FAO Progress Reports 1-18 (1971-'76) and the papers, presented at the Symposia held at Kiel (1971), Cochin (1971) and Goa (1976) and those published in various journals.

Based on above studies about ten zoogeographical regions can be recognized in the Indian Ocean and adjacent seas. These areas are characterized by special faunal associations though they also share taxa with adjacent areas. A number of species migrate into or out of the areas, depending on the prevailing currents.

Distributional studies on the zooplankton of Indian Ocean (IOBC, 1968 a, b) based on IIOE data revealed highest biomass in the Arabian Sea between Lat. 10° and 25°N and Long. 50° and 65°E, more clearly in the area off the Somali coast and the coast of Saudi Arabia. Southwest coast of India is characterized by the pattern of high zooplankton production during and shortly after the south west monsoon and subsequently low plankton densities from November/December to March/April. Also Plankton biomass level showed yearly variations.

LARVAL ABUNDANCE AND PLANKTON

Based on the distribution of fish larvae in the northern Indian Ocean nine different zoogeographical areas reflecting the hydrographical regimes were differentiated (Peter, 1982). The areas of highest abundance of larvae, though overlapped at certain places with areas of zooplankton abundance, did not always coincide with the regions of their highest density. Compared to the Arabian Sea, Bay of Bengal recorded higher numerical abundance of larvae indicating presence of hitherto unexploited pelagic fishery resources in the Bay of Bengal. Swarms of fish larvae were observed at restricted areas, perhaps owing to the social behaviour of the pelagic (nektonic) fishes leading to continuous distribution of eggs. Studies on zooplankton showed a very general relationship between zooplankton and fish larval abundance, even though a definite monthly correlation between fish larvae and zooplankton was lacking. Even though a direct relationship between certain fish larval and zooplankton abundance was not apparent, data collected within a specific zoogeographic area on zooplankton abundance still had relevance to larval distribution.

Studies by Peter (1982) on the relationship between the number of fish eggs and larvae and the volume of the respective plankton samples in the Arabian Sea and Bay of Bengal (Figs. 1 & 2) were found to be inconsistent. Moreover an inverse relationship was noticed in certain cases. These can

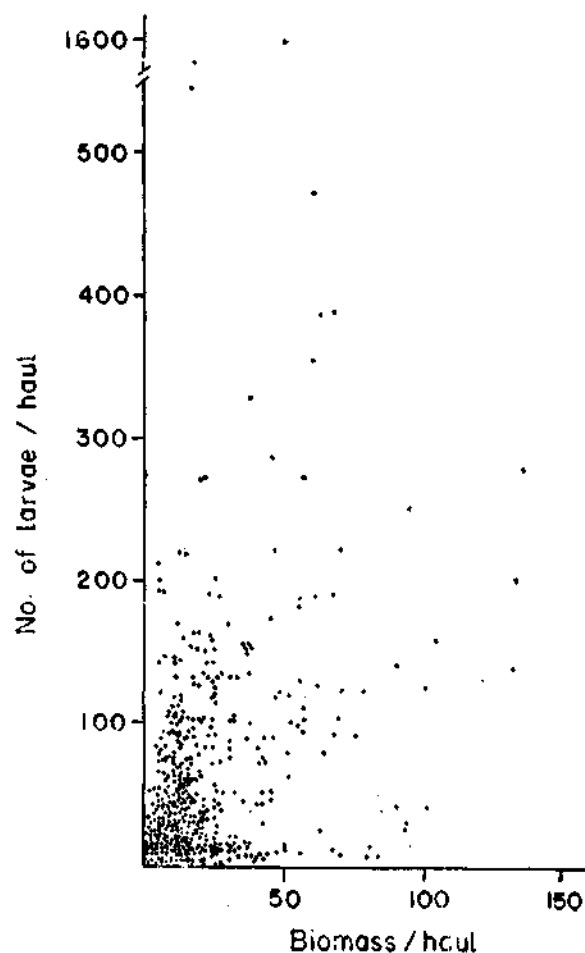

Fig. 1. Relationship between number of eggs and plankton volume in Arabian Sea.

be attributed to the samplers used, avoidance of net by larvae and the nature of sampling (vertical hauls were made instead of oblique hauls). These factors inherent in the IIOE sampling could have caused these inconsistencies. Devi (1986) found no relationship between the volume of the plankton and the number of bothid larvae. Similar observations were reported by many (Strasbery, 1960; Nakamura and Matsumoto, 1966 and Alikhan, 1972). However George (1979) has reported a positive correlation from the coastal waters of southwest coast of India.

PLANKTON AND FISHERIES

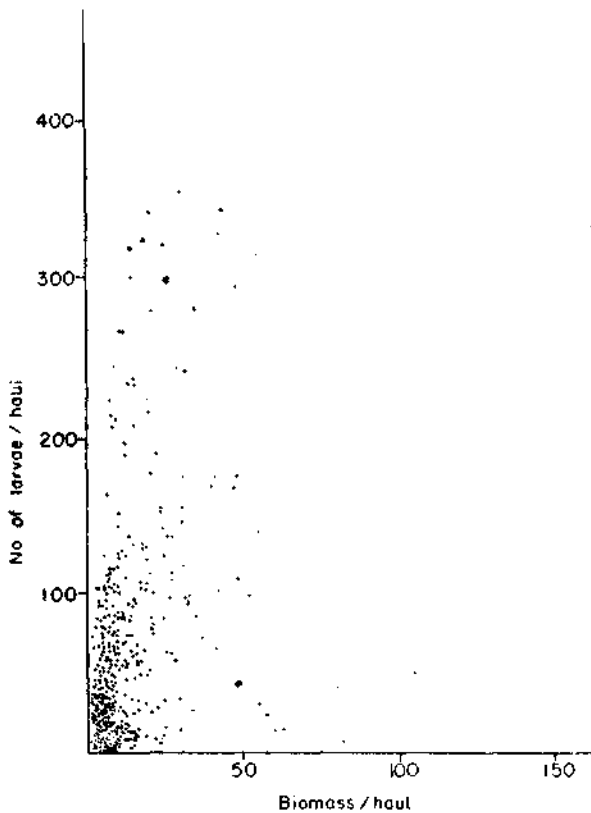

Fig. 2. Relationship between number of eggs and Plankton volumes in Bay of Bengal.

Recent studies showed that the ratio of larval fish to their food organisms varied from place to place, and that their number can be too less to affect the density of food or vice-versa. Owing to a daily rough mortality of 5 to 10% and under the diffuse process in the sea, fish larvae may become reduced in number with age. When food is scarce it leads to a reduced growth rate resulting in a long term predatory mortality. Also aggregation of predators was found responsible for the reduced number of fish larvae. Similarly absence of fish larvae can lead to survival of prey organisms, while an absolute reduction in number of patches of food organisms can be effected by the appearance of fish larvae. Cushing (1983) concluded that fish larvae are probably too dilute during the early larval phases to affect their food but as the larvae grow this tendency is reversed and larvae progressively have more and more effect on their food.

Fishery includes conventional fin and shell fishes and non-conventional associated edible biota. Development means among other consideration enhancement of known resources and location of new ones ensuring continued availability. This leads into two complex problems. Regarding the question as to how much fish can one take from the seas; fishery scientist answer this, by estimating the fish stocks of the sea. Also it depends on the harvesting capacity based on the economic considerations. The remaining basic problem is concerned with, what makes some species of fish superabundant in the ocean or why some species of fish were so successful in the sea so as to attract man by their abundance? The biological oceanographer can answer this by his extensive studies on the environment of the seas with emphasis on the role of plankton. Plankton has a major role in the variations occurring in the natural survival of larval and juvenile fish and subsequent recruitment to adult stock. Also plankton controls growth of fish. Survival of fish larvae increases with age. Both mortality and growth may vary considerably under natural conditions. The laying of large number of eggs from which only a few adults survive is a typical r-strategy. The success of which will be governed by plankton and its environmental parameters and not by the number of parent stock. At some lower levels of survival, density dependence in terms of the amount of food per organism may play a determinate role. However, the production of food organisms relative to fish feeding is still a density independent process. Normally spawning areas and seasons were located by examining the gonad condition of fishes caught at various times and places throughout the year. But recent data on ichthyoplankton component based on the actual spawned eggs and larvae collected have given us a true picture of the spawning areas and seasons. Also these data have provided us with the absolute measure of stock size, once fecundity per unit weight and the proportion of females in the stock are known. Saville (1981) and Berrien *et al.* (1981) estimated absolute size of spawning

stock size (assessment) directly from egg and larval survey data. These data when compared to catch statistics of particular fisheries can be used to indicate when the level of over exploitation is being approached.

LARVAL SURVIVAL

The importance of zooplankton as a principal source of food of marine fish larvae has been long recognized. Steele (1974) pointed out the need for more knowledge on food web cycle for the prediction of fisheries. Relatively little is known regarding the relation between prey density, growth of larvae and survival.

As early as 1914, Hjort attributed the ability of a fish population to pass through the larval period without excessive mortality as one of the primary factors determining the size of the resulting year class. Saville (1975) hypothesized that competition for food during the larval period might be a major factor affecting survival and subsequent year class strength. The stock-recruitment relationships of Beverton and Holt (1957) and Ricker (1958) indicate that the survival of larvae may be density dependent at high stock densities because recruitment does not increase at high stock levels. Density dependent factors could operate at either the intra- or inter-species level during the larval stage.

LARVAL MORTALITY

Fish larvae are ready to feed soon after the exhaustion of yolk reserves or in about two days time after hatching. According to Hunter (1976a) one of the principal causes of the marine larval fish mortality may be attributed to their starvation after yolk absorption. Starvation can be detected by morphometric, histological and chemical criteria. Feeding is effected by availability of sufficient, suitable food at a threshold concentration (Shelbourne, 1957; Lasker, 1975; Lisivenko, 1961; and SYSOEVA and Degtereva; 1965); selectivity (Blaxter, 1963 and Resenthal and Hempel, 1970) etc. Occurrence of many fish larvae showing symptoms indicative of starvation in the ocean, was reported by Balachandran

(1980). This as reported also by O'Connell (1981) implied that circumstances of insufficient food were responsible for their occurrence.

Also the proportion of larvae observed to be starving may be a useful indicator of ultimate year-class success as it indicates a substantial part of total daily mortality of the larvae. Zweifel and Smith (1981) have estimated that the average daily mortality rate for anchovy larvae of less than 10mm SL was 21% over a period of years. If starvation contributes substantially to total mortality, the proportion observed to be starving may relate reasonably well to eventual recruitment.

LARVAL PREDATION

Apart from drawing food from plankton fish larvae offer themselves as food for others. The plankton collections analysed so far revealed presence of predator species such as Chaetognaths, Siphonophores, Chondrophores, Medusae and Ctenophora at times in large numbers. Prochordates, polychaetes, heteropods, petropods, euphausiids, copepods and decapod larvae also occurred abundantly in some of these collections. The abundance of the above species was controlled more or less by the environmental parameters. Frequently a large number of fish larvae in various stages of digestion was observed in the guts of these predators. Compared to the relatively passive yolk-sac larvae, the above predators preferred actively swimming fish larvae. As ctenophores float at or near the surface, their predatory activity is confined to this zone. But siphonophores are found to be the most successful predators as they could move swiftly through waters. The predatory potential of an individual is roughly proportional to its size, whereas that of a species is related to both size and abundance. Alvarino (1981) recorded 108 predator species and noted their major abundance in hauls lacking anchovy larvae in those with aggregations of larvae. She found domination of anchovy waters by copepods and or euphausiids and larval absence in hauls dominated by pelagic prochordates.

Often the predatory pressure of zooplankters is found weaker, when there is an abundance of copepods which could be evidenced by the gut content analysis of these zooplankters. Heavy predation on fish larvae by chaetognaths and ostracods (Labour, 1923 and Nellen, 1973), by medusae like *Aurelia* and *Cyanea* (Fraser, 1969) and by copepods (Lillelund and Lasker, 1971) was reported. Predation can be seen varying annually affecting subsequent years class strength.

In a recent colloquium dealing with larval fish mortality it was concluded that "major causes of larval mortality are starvation and predation, and these may interact" (Hounter, 1976a).

It is a known fact that mortality from predation is reduced when potential predators are less in number and mortality from starvation is reduced and when fish larvae occur in waters with an adequate food supply. A fishery survives when a favourable combination of factors as above prevails as is the case reported for "anchovy water".

PLANKTON AS INDICATORS OF FISHERY

Most of the fishes have plankto-trophic larvae, their presence indicating the occurrence of the adult species which constitute the fishery. They also function as indicator organisms, whose larval life is protracted as in the case of flat fishes. Nair (1953) and Nair and Subrahmanyam (1955) correlated fluctuations in the oil sardines to the presence of a bloom of a diatom *Fragilaria oceanica*. Selvakumar (1970) realised a relationship between mackerel fishery and cladocerans—*Evadne* and *Penilia*. Sakthivel (1972) has commended on the pivotal role played by pteropods as indicators and as food for tuna and herring. Alvarino (1981) related occurrence of *Sagitta decipiens* along with anchovy larvae.

JUVENILE FISH SURVIVAL

The large number of fish larvae eaten by predators may account for the high larval mortality. Compared to the 10^8 eggs, 10^2

juveniles formed much larger prey items, but few in numbers. The more plankton those juveniles eat, the faster they grow and vice versa. While feeding is a matter of survival for larvae, it is a matter of growth rate for juveniles, all dependent on plankton availability. The most important aspect of a fish's growth for the planktonologist is not only the availability of absolute abundance of prey items but also the access to the right type of food (Parsons and Lebrasseur, 1970), as the growth efficiency is related to the nature of food (Paloheim and Dickie, 1966 b). Leong and O'Counell (1969) noticed alteration in the rate of feeding by anchovies by changing the method of prey catching from filter to reptorial feeding.

FOOD CHAIN RELATIONS

Knowing, the primary production and the quantitative transfer between trophic levels, the potential production of fish in an area—both first stage carnivores (zooplankton eaters) and predators, can be estimated. According to Gulland (1970), compared to the total annual primary production in the oceans of about 20×10^9 tons of carbon synthesized, the fish catch equivalent to 5×10^8 tons of carbon (100×10^8 tons/year of fish) shows a difference of 4,000 fold. This is because the fish being harvested are several stages removed from the primary production undergoing about 90% reduction at different trophic levels Koblentz Mishke *et al.* (1970) reporting on primary productivity data for world oceans noted low primary production over large areas of oceans and higher productivities i.e. 2 to 3 times more in the proximity of land masses. The summary given by Platt and Subba Rao (1975) indicates that the total primary productivity in the world oceans is about 31×10^9 tones carbon per year. These data obviously warrants a fresh look at previous estimates.

Recent studies show that fish production can change appreciably, most probably due to changes in the efficiency with which the primary production is converted into fish rather than changes in the total primary production. The world's catch of marine fish in 1966

was about 44 million tons (FAO, 1967) in addition to 5 million tons of crustaceans, molluscs etc. This catch almost doubled to 85 million tons (FAO, 1987) in 1985, expanding at around 5% per year. The present catch is close to the global estimate of 100×10^6 tons/yr. This tremendous difference in catch data can be attributed to one of the three factors low estimation of production, factual increase in production or an intensive fishing, removing an accumulated stock so far not exploited by altering the size spectrum harvested.

Slobodkin (1961) indicated a value of ecological efficiency at about 10%. Schaefer (1965) considering the effect of ecological efficiencies ranging from 10 to 20%, noted an order of magnitude of increase in the production of fish at the fifth trophic level. In general, the trophic levels included are—autotrophs and saprophages at the first trophic level; herbivorous organisms as nauplii of copepods, some copepodite stages, Oikopleura and the larvae of some benthic molluscs and polychaetes at the second trophic level; omnivorous organism as later stages of copepods, Acartia, Oithona and Centropages at the third level; primary carnivores as adult Oithona at the fourth level; secondary carnivores as Chaetognaths at the fifth level and the tertiary carnivore Pleurobrachia at the sixth level feeding on all other zooplanktons (Petipa *et al.*, 1970). It is interesting to note that certain organisms get transferred from one level to the other during their growth.

Ryther (1969) considered the number of trophic levels in three communities which may be described as oceanic, continental shelf and upwelled. He suggested that oceanic communities have long food chains as a continuous flow of biomass from phytoplankton to fish, with low ecological efficiencies decided by the three or four levels of carnivorous feeding. The oceanic area generally with slow annual primary production average value of $50 \text{ g C/m}^2/\text{yr}$ required five trophic levels leading to the production of fish. The second food chain described as coastal or continental shelf occurring in areas where the total annual primary

production is about $100 \text{ g C/m}^2/\text{yr}$, consists of three trophic levels whether this is via the benthic or pelagic community. The third chain of upwelling areas with a primary production of $300 \text{ g C/m}^2/\text{yr}$ represents as one and a half trophic levels - adult anchovy feeding directly on phytoplankton and whales feeding on euphausiids

In the above three communities ecological efficiencies at each trophic level were assumed to be highest when governed largely by phytoplankton/herbivore associations and lowest for communities in there which were secondary and tertiary carnivores. Consequently a 10, 15 and 20% efficiency was assigned to be oceanic, coastal and upwelling food chains respectively. From this Ryther estimated the potential fish production of 36,000, 340 and $0.5 \text{ mg C/m}^2/\text{hr.}$ for the upwelling, shelf and oceanic areas respectively.

A change in the pattern of feeding as the case with anchovies which usually feed on phytoplankton but at times feeding on zooplankters, can reduce the overall efficiency of transfer of energy from phytoplankton to zooplankton feeders. Similarly plaice larvae feeding on some large diatoms as *Biddulphia* and *Coscinodiscus* in the earlier feeding stage, can be seen abruptly changing to a zooplankton diet of Oikopleura. The changes in the efficiency may be due to qualitative changes in the zooplankton consumed as is the case with herring feeding on large *Calanus* instead of small *Temora* and *Pseudocalanus* (Steele, 1965). Eventhough there seem to be no relation between the total food supplies and the larval fishes, certainly food supplies, possibly of a particular type at a particular time—eg. When the yolk sac supplies are finished—may be critical.

An important property of food web is its stability that is the ability of a system to maintain itself after a small external perturbation (Hurd *et al.*, 1971). Mac Arthur (1955) has postulated that development of many species (ie. a high diversity) is the principal component in establishing community stability. But productivity for unit biomass will be low as the complex food web requires more energy. Thus the tropical plankton communities and

food web with high diversity and stability lead to low productivity in general. In contrast the plankton community in temperate waters with low stability and diversity leads to high productivity, contributed by one or two species. Stabilization was also maintained by the imposition of a limitation on the predator, by periodic migration of the predator away from its food source, by the patchiness of the prey distribution and by the imposition of a threshold concentration below which the prey is not consumed by the predator. Examples can be found in the diel migration of zooplankton into the euphotic zone (Mc Laren, 1963 and Balachandran, 1980); in the ability of zooplankton such as euphausiids, to change from carnivores to herbivores (Parsons, and Le Brasseur, 1970); and in the occurrence of a threshold prey concentration in phytoplankton/zooplankton relationships (Parson *et al.* 1967); On the other hand instability may be imparted in a plankton community by time delays (Dickie and Mann, 1972) as is the case with the brancle community depending on timing of *Skellonama* bloom for the release of its larvae (Barnes, 1956).

In an aquatic ecosystem, a perturbation applied to the top of a food chain (as removal of predators) would have more effect resulting in an increased biomass (fish production) than one applied to the bottom of the food chain (as added nutrients). In the marine environment as the exchange of water may remove organisms in the study area, it is difficult to establish density dependent relationships between the growth of planktivorous fish and plankton growth rates. Abundance of fish is generally related to the abundance of plankton. The depensatory mechanism can be noted when a large number of fish larvae compete so heavily for a limited amount of food that the survivors may become much smaller than if fewer larvae were present initially. Similar definite reduction in growth rate of haddock larvae was noted by Gulland (1962) and Beverton and Holt (1957), during period of high stock abundance (Raitt, 1939). Often predation by planktivorous fish on plankton community may affect the size structure of an aquatic food web (Brooks and Dobson 1965). Abundance of planktivorous fish promote

growth of smaller zooplankton and phytoplankters, while larger zooplankton flourished with fewer fishes.

CONCLUSIONS

The following inferences can be arrived at from the above observations:

- a) The highlight of this study on the role of plankton in the fisheries development is that helps us to answer the basic question in biological oceanography, as to why some species of fish are superabundant in certain areas.
- b) Plankton biomass act as an index of fertility of the oceans, giving us an estimate of the total organic production and helping us to chart out the areas of fishery potential.
- c) Fish production can change due to changes in the efficiency with which the primary production is converted in to fish rather than changes in the total primary production.
- d) The spawning stock size can be estimated directly from the egg and larval survey data.
- e) Plankton offer themselves as the principal source of food, the variability in their composition affecting food habits of the fishes.
- f) Plankton assemblages indicated the role of plankton as a deciding factor in the spawning of fishes.
- g) A fishery survives when a favourable combination of factors prevails, adequate food supply and reduced prey density.
- h) One of the prime factors deciding the size of the resulting year class is its ability to pass through the larval life without excessive mortality.
- i) Zooplankton predation on fish larvae affect subsequent year class strength/fisheries.
- j) The percentage of starved larvae can be an indicator of ultimate year class strength.

- k) Certain planktonic species act as indicators of fisheries.
- l) A multitude of factors control the extent of variations noted in the survival of larval and juvenile fishes.

FISHERY MANAGEMENT

The role of plankton in fisheries management can be as follows:

- a) The spawning stock size directly estimated from the egg and larval survey data, when compared to catch statistics of particular fisheries can be used to indicate when the level of over-exploitation is being approached.
- b) The conventional method of estimating stock sizes from commercial fisheries was found inapplicable where fisheries have been prohibited due to depletion of stock.
- c) Studies on plankton allow us to understand the natural ecosystem in order to answer the question—how much fish can be caught from the sea.
- d) Plankton studies help us to understand the effect of removing large quantities of fish from the same natural ecosystem.

We are greatly indebted to Dr. B. N. Desai, Director, National Institute of Oceanography Dr. M. Krishnankutty, Scientist-in Charge of this centre, for their permission in presenting this paper.

REFERENCES

- ALIKHAN, J., 1972. Distribution and abundance of fish larvae in the Gulf of Aden and in the waters off the coast of W. Pakistan in relation to the environment. *DISS KIEL*: 191.
- ALVARINO, A., 1981. The relation between the distribution of zooplankton predators and Anchovy larvae. *Rapp. P-V. Reun. Cons. int. Explor. Mer.*, 178: 197-199.
- BALACHANDRAN, T., 1980. Studies on Mero-plankton. *Ph. D. Thesis University of Cochin*: 319 pages.
- BARNES, H., 1956. *Balanus Balanoides* (L) in the Firth of Clyde: the development and annual variation of the larval population and the causative factors. *J. Anim. Ecol.*, 25: 72-84.
- BERRIEN, P. L., NAPLIN, N. A. AND M. R. PENNINGTON, 1981. Atlantic Mackerel *Scomber Scombrus* egg, production and spawning population estimates for 1977 in the Gulf of Maine, Georges Bank and Middle Atlantic Blight. *Rapp. P-V. Reun. Cons. Int. Explor. Mer.*, 178: 279-288.
- BEVERTON, R. J. H. AND HOLT, S. J., 1957. On the dynamics of exploited fish Populations. *Fish. Inv. Lond. Ser. II*, 19: 1-533.
- BLAXTER, J. H. S., 1963. The feeding of herring larvae and their ecology in relation to feeding. *Calif. Coop. Oceanic Fish. Invest. Rep.*, 10: 79-88.
- BROOKS, J. L., AND DOBSON, S. I., 1965. Predation body size and composition of plankton. *Science*, 150: 28-35.
- CUSHING, D. H., 1983. are fish larvae too dilute to affect the density of their food organisms?. *J. Plankt. Res.* 5: (6): 847-854.
- DEVI, C. B. L., 1986. Studies on the flat fish (Heterosomata) larvae. of the Indian Ocean. *Ph. D. Thesis, Univ. of Kerala*, 480 pp.
- DICKIE, L. M. AND MANN, K. H., 1972. Aquatic ecological systems: the formal approach to holistic models. (Unpublished).
- FAO, 1967. *Year Book of fishery Statistics-Catches and landings, 1966*, 22, FAO.
- FAO, 1987. Review of the State of World Fisheries Research. *FAO. Fisheries Circular No. 710*.
- FRASER, J. H., 1969. Experimental feeding of some medusae and chaetognatha. *J. Fish. Res. Bd. Canada*, 26: 1743-1762.

- GEORGE, K. C. 1979. Studies on the distribution and abundance of fish eggs and larvae off the southwest coast of India with special reference to Scombroids. *Ph. D. Thesis*, Univ. of Cochin, 197 pp.
- GULLAND, J. A., 1962. The application of mathematical models to fish populations. In: *The exploitation of natural animal populations*, edited E. D. Le Cren and M. W. Holdgate, Uxforde, Blackwell Scient. Publs., 214-217.
- GULLAND, J. A., 1970 a Food chain studies and some problems in world fisheries. *Marine Food Chains* (ed. J. H. Steel), Olive and Boyd, Edinburgh: 296-315.
- GULLAND, J. A., 1970 b The fish resources, of the oceans. *FAO Fish. Tech. Pap.* No. 97: 423.
- HJORT, J., 1914. Fluctuations in the great fisheries of northern Europe viewed in the light of biological research. *Rapp. P.-V. Reun. cons. person. int. explor. Mer.*, 20: 1-228.
- HUNTER, J. R., (ed.), 1976. Report of a Colloquium on larval fish mortality studies and their relation to fishery research, January, 1975. *NOAA, NMFS, Tech. Rept. Circ.* 395: 1-5.
- HUNTER, J. R., 1976a. Report of a colloquium on larval fish mortality studies and their relation to fishery research January, 1975. *NOAA Tech. Rep. NMFS Cir.*, 395 5 pp.
- HURD, L. E., V. M. MELLINGER, L. L. WOLFE AND S. J. MC NAUGHTON, 1971. Stability and diversity of three trophic levels in terrestrial successional ecosystems. *Science*, 173: 1134-1136
- IOBC, 1968 a & b. IIOE Plankton Atlas, Vol. I, Fasc. I & II, IOBC, Cochin.
- KOBLENTZ-MISHKE, O. J., V. V. VOLKOVINSKY AND J. G. KABANOVA, 1970. Plankton primary production of the world oceans In: *Scientific Exploration of the South Pacific*. Standard Book No. 309-01755-6, Nat. Acad. Sci., Washington, pp. 183-193.
- LEBOUR, M. V. 1923. The food of plankton organisms. *J. mar. biol. Ass. U. K.* 12: (4): 644-677.
- LEONG, R. J. H. AND C. P. O'CONNELL, 1969. A Laboratory study of particulate and filter feeding of northern anchovy (*Engraulis mordax*). *J. Fish Res. Bd. Canada*. 26: 557-582.
- LILLELUND, K. AND LASKER, R., 1971. Laboratory studies of predation by marine copepods on fish larvae. *Fish. Bull.*, 69: (3): 655-667.
- LISIVNENKO, L. N., 1961. Plankton and the food of larval Baltic herring in the Gulf of Riga. *Fish. Res. Bd. Canada, Trans.* No. 444, pp. 36, 1963.
- MAC ARTHUR, R. H., 1955. Fluctuations of animal populations and a measure of community stability. *Ecology*, 36: 533-536.
- MC LAREN, I. A., 1963. Effect of temperature on growth of zooplankton and the adaptive value of vertical migration. *J. Fish. Res. Bd. Canada*, 20: 685-727.
- NAKAMURA, E. L., AND W. M. Matsumoto, 1966. Distribution of larval tunas in Marquesas waters. *U. S. Fish Bull.*, 66: (1): 1-22.
- NAIR, R. V., 1953. Studies on the life-history, bionomics and fishery of the white sardine, *Kowala coval* (Cuv.). *Proc. Indo-Pacific Fish Coun.*, 103-118.
- NAIR, R. V. AND SUBRAHMANYAM, R., 1955. The Diatom, *Fragilaria Oceanica* cleve, an indicator of abundance of the Indian oil sardine, *Sardinella longiceps* Cuv. & Val. *Curr. Sci.* 24: 41-42.
- NELLEN, W., 1973. Kinds and abundance of fish larvae in the Arabian Sea and Persian Gulf. In: *The biological of the Indian Ocean*. B. Zeitzschel (Ed.), Springer-Verlag, Berlin, 415-430.

- O'CONNEL, C. P., 1976. Histological criteria for diagnosing the starving condition in early post yolk sac larvae of the northern anchovy, *Engraulis mordax* Gird. *J. exp. mar. Biol. Ecol.*, 25: 285-312.
- O'CONNELL, C. P., 1981. Estimation by histological methods of the present of starving larvae of the northern Anchovy (*Engraulis mordax*) in the sea. *Rapp. P-V. Reun. Cons. Int. Explor. Mer.*, 178: 357-360.
- PALOHEIMO, J. E. AND DICKIE, L. M. 1966b. Food and growth of fishes. III. Relation among food, body size and growth efficiency. *J. Fish. Res. Bd. Canada*, 23: 1209-1248.
- PARSONS, T. R., R. J. LEBRASSEUR AND J. P. FULTON, 1967. Some observations on the dependance of zooplankton growing on the cell size and concentration of phytoplankton blooms. *J. Oceanogr. Soc. Japan*, 23: 10-17.
- PARSONS, T. R. AND LEBRASSEUR, R. J., 1970. The availability of food to different trophic levels in the marine food chain. In *Marine Food Chains*. (Ed.) J. H. Steele, Oliver & Boyd, Edinburg, 325-343 pp.
- PETER, K. J., 1982. Studies on some fish larvae of the Arabian Sea and Bay of Bengal. *Ph. D. Thesis*, Univ. of Cochin, 349 pp.
- PETIPA, T. S., E. V. PAVLOVA AND G. N. MIDONOV, 1970. The food web structure, utilization and transport of energy by trophic levels in the planktonic communities. In *Marine Food Chains*, (Ed.) J. H. Steele, Oliver & Boyd, Edinburg, 142-167.
- PLATT, T. AND SUBBA RAO, D. V., 1975. Primary production of marine microphytes. In: *Photosynthesis and productivity in different environments*. Cambridge Univ. Press (U. K.), 249-280.
- RAITT, D. S., 1939. The rate of mortality of the haddock of the North Sea stock 1919-38. *Rapp. P-V Reun. Cons. Perm. Int. Explor. Mer.*, 110: 65-80.
- RICKER, W. E., 1958. Handbook of computation for biological statistics of fish populations. *Fish. Res. Bd Bull* 119. 300 pp.
- ROSENTHAL, H. AND HEMPEL, G., 1970. Experimental studies in feeding and food requirements of herring larvae (*Clupea harengus* L.) in *marine food chains*. Ed. J. H. Steele; Oliver & Boyd, Edinburg, 344-364.
- RYTHER, J. H., 1969. Photosynthesis and fish production in the sea. The production of organic matter and its conversion to higher forms of life vary throughout the world ocean. *Science*, 166: 72-76.
- SAKTHIVEL, M., 1972. Studies on the Euthycosomata of the Indian Ocean. *Ph. D. Thesis*, Univ. of Cochin.
- SAVILLE, A., 1975. Application of Ichthyoplankton studies of fishery management. *UNESCO Tech. Pap. in Mar. Sci.*, 20: 25-27.
- SAVILLE, A., 1981. The estimation of spawning stock size from fish egg egg and larval surveys. *Rapp. P-V. Reun. Cons. Int. Explor. Mer.*: 178: 268-278.
- SCHAEFER, M. B. 1935. The potential harvest of the sea. *Trans. Amer. Fish. Soc.*, 64: 123-128.
- SELVAKUMAR, R. A., 1970. Cladoceran swarm in relation to Mackerel fishery along the west coast of India. *Curr. Sci.*, 39: No. 21: 481-482.
- SHELBOURNE, J. E., 1957. The feeding and conditions of plaice larvae in good and bad plankton patches. *J. mar. biol. Ass. U. K.*, 36: 539-552.
- SLOBODKIN, L. B., 1961. Growth and Regulations of Animal Populations (Ch. 12). Holt, Rinehart and Winston, New York, 184 pp.

- STEELE, J. H., 1965, Some problems in the study of marine resources. *Spec. Publs. int. Comm. N. W. Atlant. Fish.*, 6: 463-476.
- STEELE, J. H., 1974. *The structure of marine ecosystems*. Harvard Univ. Press, Cambridge, mass. 128 pp.
- STRASBERG, D W., 1960. Estimates of larval tuna abundance in the central Pacific. *U S Fish. Bull.* 60: (1967): 231-235.
- SYSOEVA, T. K. AND DEGTEREVA, A. A., 1965 The relation between the feeding of cod larvae and pelagic fry and the distribution and abundance of their principal food organisms *ICNAF Spec. Publ.* 6: 411-416
- ZEWEIFEL, J. R. AND SMITH, P. E., 1981. Estimates of abundance and mortality of larval anchovies (1971-75). Applications of a new method *Rapp. P.-V. Reun. Cons. Int. Explor. Mer.*, 178: 248-259.

STUDIES ON UPWELLING AT THE TURN OF THIS CENTURY

A. V. S. Murty
Central Marine Fisheries Research Institute, Cochin

ABSTRACT

Upwelling in the waters around India and the transformation of physical properties of the neritic waters thereof with a stress on thermal front and the potential utility for fish production in the sea are described. The necessity of obtaining the snapshot pictures with high grade resolution of locations and intensities of upwellings and thermal fronts is stressed for effective management of marine fisheries. The only means of fulfilling this objective is by switching over the observations from the time-consuming ship-borne observations to satellite produced imagery system. Therefore, by the turn of this century, the software suitable for localised conditions should be developed and perfected so that the present day sea truth data collection system by ships would be used only as occasional checking points.

INTRODUCTION

Of all the coastal upwellings, the Peruvian upwelling is world famous because of its tremendous and wide-spread influence coupled with El Nino effect on anchovy fishery fluctuations extended to bird-migration (Causing, 1982; Breaker and Christopher, 1986; Wooster and Reid Jr., 1963). Though the phenomenon of upwelling actually means the vertically upward drawn currents from mid-depths towards the surface, the phenomenon is well understood by its effects on the surface and subsurface waters. The impact of southwest monsoon coupled with coastal currents is to generate upwelling along

the coast of India. The entire west coast, particularly the southwest coast, and the northern half of east coast experience upwelling in different degrees during the southwest monsoon period (summer). Under the influence of the offshore winds of the northeast monsoon with the least opposition by the weaker northerly currents, upwelling is generated off Bombay region during winter (Carruthers *et al.*, 1959; Banse, 1968; Murty, 1981).

Waters of the southwest and central west coast of India (between 7°N to 17°N) are explored with regards to upwelling and thermocline over a long number of years (Murty, 1965;

Narayana Pillai, 1982; Ramamirtham and Rao, 1973; Ramamirtham and Jayaraman, 1960; Sastry and D. Souza, 1972; Sharma, 1968; Lathipha and Murty, 1978; Anonymous, 1980, Johannessen, Subbaraju and Blindheim, 1981). Studies on upwelling in the waters off east coast were very limited in space and time (LaFond, 1954, 1958; Murty and Varadachari, 1968; Ramasastry and Murty, 1958).

From the predominant commercial fisheries point of view, turbidity and temperature of the neritic waters and the temperature of the offshore waters play a dominant role in determining the species distribution and abundance. In a limited sense, the boundary, the region of transition, between the mixed layer and the thermocline below it may be treated as a "thermal front", the first order discontinuity in temperature.

The effects of the phenomenon of upwelling are manifold. The upwelling waters are productive with enrichment of nutrients. Therefore they serve as green pastures or nursery grounds of young fish. The locations of thermal fronts are controlled by upwelling. Fish congregations are known to be associated with frontal regions (Taivo Laevastu and Ilmo Hela, 1970; Cushing 1982). Hence the locations of thermal fronts indicate where to fish and a what depth to lower the fishing gear.

The negative effect of upwelling is to replace aerated waters (4-5 ml/l of dissolved oxygen) with oxygen depleted waters (oxygen content 1 ml/l or even less). Adult fish may perhaps require normally aerated waters: therefore it migrates away from the oxygen depleted upwelled waters. This is observed in the northwest bottom fishery (Carruthers *et al.*, 1959; Banse, 1968). The bottom fishes were found to migrate either nearer to the coast or to the far off region in their effort to avoid the wide belt of upwelled region along the coast with the result that the bottom fishery was not profitable within the belt of upwelling area. Therefore the negative effect of upwelling serves as a precaution in selecting the fishing ground.

Different species of tuna prefer different locations of temperature conditions: the yellowfin tuna prefers the warmer (upper side) of the

thermal front associated with the thermocline, whereas the bigeye tuna prefers the colder (lower) side of the front, while albacore tuna is much deeper (colder)-water-living (Laevastu and Ilmo Hela, 1970).

It is evident, therefore, for economic exploitation of fishery resources of the sea identification of exact location of upwelling, its intensity and extent are required to be known without delay. Charting out the details of upwelling by making ship-board observations involve a lot of time. And such information is useful mainly to hind-cast the fisheries

Satellite as Ocean Information Centre

Satellite-borne radiometric techniques were developed for ocean use. Radiation emitted by the surface of the earth or sea which is in the infrared range of wavelengths is a function of surface temperature itself. The emitted radiation is absorbed, chiefly by highly variable water vapour in the atmosphere, before it reaches the height of the satellite where it is detected and measured by radiometer. Nevertheless, from the measurements made from the several atmospheric-window channels with the aid of space-borne high resolution radiometer, it was not only made possible to correct for the atmospheric attenuation, but also to attain spatial resolution as close as 1.1 km locally (Paul Mc Clain, 1985).

The productivity of the waters is determined by optical radiometer - blue colour representing low productivity and green colour high productivity. Turbidity of the waters is determined by reflectometer. Procedures for ocean surface wind vector retrievals from scatterometer data are being developed.

A satellite-oriented study of albacore tuna catch distributions off the west coast of North America showed clearly that the distribution and availability of albacore tuna are closely related to oceanic fronts. Significant albacore aggregations in nearshore regions were found near fronts associated with upwelling and with shoreward intrusions of oceanic water. Bluefin tuna catch in the Gulf of Mexico was well correlated with the proximity of the surface thermal front which was determined by visible

and infrared satellite imageries. Squid jigging within ten nautical miles of the shelf slope front of the northwest Atlantic was of much higher catch rate than the catch rate of other areas (Paul McClain, 1985).

Remote sensing in Marine Fisheries in India

Cushing (1969) feels that the intermittent halts in upwelling process actually sustain greater levels of production. As monsoons and upwellings in Indian waters are closely linked up, breaks in monsoons may lead to such sustained production by resumed upwellings. This view again supports the need for monitoring of upwelling systems of Indian waters by quick and accurate method / e. by remote sensing.

India has started gaining experience in remote sensing of coastal zone and marine resources through chlorophyll mapping with ocean colour scanner and sea surface temperature estimation from infrared radiometer (Pranav Desai, 1985). Regionally applicable software is being developed by Indian Space Research Organisation (ISRO) at its centres at Bangalore and Ahmedabad and also by National Remote Sensing Agency (NRSA) at Hyderabad. The geostationary Indian national satellite, Insat-1B, has successfully completed 100 days of its continuous operation by 7th May 1987. Its very high resolution radiometer has given thousands of meteorological images useful for flood control in specific catchment areas of rivers in the country.

However, the monsoons and their associated thick cloud cover and breaks in monsoon make the problem of atmospheric correction of satellite data more serious. The hinderances posed by the unique climatic conditions of Indian sub-continent and of the seas around it have to be sorted out for their elimination from the remote sensing data. Empirical solutions may not stand the test of time. Nevertheless, various models based on multichannel system have to be evolved in this direction.

It may be pointed out that our Indian space applications to sea conditions are still at the initial stage of having sea truth data to function as yard-stick to calibrate the satellite imagery data every time. It means that we have to wait

for a long for the results, as the sea truth data which is nothing but ship-borne instrumental data takes time for its final results. Therefore this system should be made perfect for our waters so that by the turn of this century the function of sea truth data reduces to checking points only. Then the satellite imagery perfected in its calibration gives synoptic picture like the bird's eye-view, of what is happening in the surface and subsurface waters, what is needed is consistent quality of monitoring data on locations of upwellings, their breaks and changes of fronts with time (frontogenesis and frontolysis) which are all essential for effective forecasting of fisheries for augmentation and judicious fishing from the seas around India.

REFERENCES

- ANONYMOUS, 1980, Oceanographic investigations along the southwest coast of India (1976-78). FAO Field document 5, FI : DP/IND/75/038, pp. 51.
- BANSE, K. 1963. Hydrology of the Arabian Sea Shelf of India and Pakistan and effects of demersal fishes. *Deep-sea Res.*, 15 : 45-79.
- BREAKER, L. C. AND N. K. CHRISTOPHER 1986. Oceanic variability off the Central California coast *Prog. Oceanog.*, 17 : 61-135.
- CARRUTHERS, J.N., S.S. GOGATE, J.R. NAIDU AND T. LAEVASTU 1959. Shorewards upslope of the layer of minimum oxygen of Bombay, its influence on marine biology, especially fisheries. *Nature*, 183 : 1084-7.
- CUSHING, D. H. 1939. *Upwelling and Fish Production*. FAO Fisheries Technical Paper No. 84 : 40 p.
- CUSHING, D. H. 1982. *Climate and Fisheries*. Academic Press, New York, 373 p.
- ISRO 1985. Remote Sensing in India. ISRO Technical Report No. 57-85, 64 p.
- JOHANNESSEN, O. M., G. SUBBARAJU AND J. BLINDHEIM 1981. Seasonal variations of the oceanographic conditions off the southwest coast of India. *Fisk Dir. skr. Ser. Hav Unders.*, 18 : 247-261.

- LAFOND, E.C. 1954. On upwelling and sinking off the East coast of India. *Andhra Univ. Mem. Oceanogr.*, 1 : 117-122.
- LAEVASTU, T. AND ILMA HELA. 1970. *Fisheries Oceanography*. Fishing News (Books) Ltd. 238 P.
- LAFOND, E. C. 1958. On the circulation of the surface layers off the east coast of India *Andhra University Memoirs in Oceanography, Series 62* : 1-11.
- LATHIPHA, P. N. AND A. V. S. MURTY 1978. Studies of upwelling along the west coast of India using geopotential anomaly. *India J. Mar. Sci.*, 7 : 219-223.
- MURTY, A. V. S. 1965. Studies on the surface mixed layer and its associated thermocline off the west coast of India and the inferences thereby for working out a prediction system of the pelagic fisheries of the region. *Indian J. Fish.*, 12 : 118-134.
- MURTY, A. V. S. 1981. Observations of coastal water upwelling around India. In: Lighthill, J. and R. P. Pearse (Eds): *Monsoon dynamics*, Cambridge University Press, pp. 523-528.
- MURTY, C. S. AND VARADACHARI, V. V. R. 1968. *Bull. Natn. Inst. Sci. India* 38 : 80-86.
- NARAIN, A., R. N. JADHAV, K. L. MAJUMDER, G. P. SHARMA, K. M. JOSEPH, E. G. SILAS, P. V. R. NAIR, G. SUBBARJU, V. K. PILLAI, A. G. PONNIAH AND V. K. BALACHANDRAN. Remote Sensing of Ocean Colour and Targeting of Fish Schools from Airborne sensors. *Proc Seminar on Remote Sensing in Marine Resource* held at Cochin. (Eds) A. K. S. Gopalan and E. G. Silas, April 1985, pp. 5.1-5.8.
- NARAYANA PILLAI, V. 1982. Physical characteristics of the coastal waters off the southwest coast of India with an attempt to study the possible relationship with sardine, mackerel and anchovy fisheries. *Ph. D Thesis*, University of Cochin, 107 p
- PAUL McCLAIN, E. 1985. Applications of Multichannel sea surface temperatures in physical and biological oceanography. *Proc. US - India Symposium-cum-workshop on Remote Sensing Fundamentals and Applications* held in March 1985 at Space Applications Centre, Ahmedabad, pp. 89-97.
- PRANAV S. DESAI 1985. An overview of some Indian Experiences in Remote Sensing of coastal zone and Marine Resources. *Proc. US-India Symposium-cum-workshop on Remote Sensing Fundamental and Applications* held in March 1985 at Space Applications Centre, Ahmedabad, pp. 109-114.
- RAMAMIRTHAM, C. P. AND R. JAYARAMAN 1960. Hydrographical features of the continental shelf waters off Cochin during the year 1958-59. *J. mar. biol. Ass. India*, 1 : 199-207.
- RAMAMIRTHAM, C. P. AND D. S. RAO 1973. On upwelling along the west coast of India. *J. mar. biol. Ass. India*, 15: 306-317.
- RAMASASTRY, A. A. AND C. B. MURTY 1958. *Proc. Indian Acad. Sci.*, 46B: 293-323.
- SHARMA, G. S 1968. Seasonal variation of some hydrographic properties of the shelf waters off the west coast of India. *Bull. Nat. Inst. Sci., India*, 38: 263-276.
- SASTRY, J. S. AND D'SOUZA, R. S. 1972. Upwelling and upward mixing in the Arabian Sea. *Indian J. Mar. Sci.*, 1 : 17-27.
- TAIVO LAEVASTU AND ILMO HELA 1970. *Fisheries Oceanography*. Fishing News (Books) Ltd., London, pp. 238.
- WOOSTER, W. S. AND REID, Jr. L. L. 1963. Eastern boundary currents. In : *The sea* (ed) M. N. Hill John Wiley and Sons. Vol. 2 : 253-80.

POTENTIAL APPLICATIONS OF SATELLITE REMOTE SENSING TECHNIQUE IN OCEANOGRAPHY AND FISHERIES

P. V. R. Nair, V. K. Pillai and V. K. Balachandran
Central Marine Fisheries Research Institute, Cochin

A wide range of data collection can be achieved by remote sensing in oceanography and fisheries which by conventional ship-board observation would take considerable time and effort. IRS 1 (Indian Remote Sensing Satellite 1), expected to be launched this year by ISRO, will form the first of a series of operational remote-sensing satellites in resources survey. The Joint Experiments Programme (JEP) for the development of suitable sensors in marine fisheries, organized by ISRO in collaboration with CMFRI and FSI, enabled the development of suitable sensors in the estimation of chlorophyll and bioproductivity. In addition to the IRS Utilization Programme, SPOT, LANDSAT MSS and TM data also will be available for this. The major thrust from these studies will be on the structure and synoptic variability of oceanic fronts, observations on eddies, their formation and evolution, internal waves through panoramic images, precipitation intensity in oceanic areas, ocean currents by drifting buoys with transponders and distribution pattern of chlorophyll in coastal waters by means of differential spectra analysis of radiance. These parameters can provide considerable information to aid in forecasting, exploitation and management of fisheries which have been discussed in this account.

INTRODUCTION

Remote sensing is emerging as a major application of space technology for the survey and management of natural resources. The entire band of the electro-magnetic spectrum is selectively used to study the surface of the earth and the oceans. Radiations from the target areas are received by suitable sensors in aircraft and satellites and the data are transmitted back to ground stations. Modern data interpretation techniques are then employed in conjunction with sample 'ground truth' or 'sea truth' data to generate a variety of important information required by resource scientists, planners and administrators.

Ocean colour represents mean distribution of radiant energy as a function of wave length. It is well known that the oligotrophic waters are blue and eutrophic waters are green in colour. It is now possible to measure this colour by remote sensing technique. The concept of using radiance ratios for various wavelengths in remote sensing application of ocean colour has thus been well-established.

The use of remotely sensed data in coastal and marine studies was initiated in India some-time around mid-seventies, with the availability of landsat data and also, aerial panchromatic

and other types of cameras. The early studies dealt largely with coastal zone aspects such as shoreline change mechanisms at major river deltas, wetland monitoring etc. Another area of marine application that was receiving attention was fisheries.

The application of remote sensing technique for marine fisheries research in India is comparatively of recent origin. However, the erstwhile UNDP pelagic project, in which the scientists of CMFRI were actively involved, had been using aerial survey for observing the distribution and quantification of pelagic resources. But no serious attempt has been made to utilize satellite sensor data in oceanographic and marine fisheries applications until very recently.

In the early eighties a Joint Experiment Programme (JEP) was conceived by ISRO in collaboration with CMFRI and Fishery Survey of India. The major thrust of the work was in the development of suitable sensors for the Indian Remote Sensing Satellite in oceanographic and marine fisheries research. The sea truth data collected during these investigations were codified and presented at a Seminar on Remote Sensing in marine resources held at Cochin in 1985. (Silas *et al.*; 1985; Gopalan and Narain; Narain and Dwivedi; Neera Chaturvedi *et al.*,

Dwivedi *et al.*, 1985). This seminar mainly dealt with the biological productivity and fishery resources of the Indian waters and the true utilization of LANDSAT-MSS and NIMBUS-7 CZCS data in ocean colour sensing and phytoplankton pigment mapping. In addition, the Ocean Colour Radiometer (OCR) commissioned by the NRSA in collaboration with DFVIR of Federal Republic of Germany was used for chlorophyll scanning in experiments in the Arabian Sea in order to establish an algorithm through which chlorophyll, yellow substances and suspended sediments could be quantitatively determined (Muralikrishna, 1983). The above investigations have given some insight into the possibility of remotely sensed data collected from low flying aircraft and through satellites with various sensors in determining the relative variations in the bioproductivity and thereby fish aggregations. The possibility of using IRS data in the coming decades by the Institute (CMFRI) requires an indepth study by a team in order to develop the infrastructure for interpretation and dissemination for the benefit of the industry.

Chapman (1969) has indicated that in marine fisheries resource exploitation, 65% of time is spent as search time, 10% for catching and the balance for travelling to and from the fishing grounds. Hence remote sensor capabilities can have the greatest impact by introducing big improvements in the search time. Some of the properties of the sea that are amenable to remote sensing are sea surface temperature which will make it possible to predict migration of marine fishes and water fronts where fishes tend to aggregate.

Application potential of IRS systems

The IRS has two camera systems with sensors in four spectral bands operating between 0.45 to 0.86 microns. The capacities of these bands in terrestrial and marine applications are given in Table 1. Applications to coastal, estuarine and ocean environments as envisaged by ISRO from IRS and LANDSAT- MSS imagery are (1) study of sediment behaviour in estuarine mouth, (2) monitoring littoral processes and effects of the coastal structure, (3) evaluation of suspended matter and (4) nearshore bathymetry (IRS - Data Book DOS - 1986).

TABLE - 1.

IRS Spectral Bands and Principal Applications

Band	Spectral range (microns)	Principal Applications
1	0.45-0.52	Sensitivity to sedimentation, deciduous / coniferous forest cover discrimination.
2	0.52-0.59	Green reflectance of healthy vegetation
3	0.62-0.68	Sensitivity to chlorophyll absorption by vegetation, differentiation of soil and geological boundaries.
4	0.77-0.86	Sensitivity to green biomass and moisture in vegetation

From LANDSAT imagery it has also been possible to monitor pollution by following the plumes of discharging rivers and large sewage outfalls and also plumes of sludges dumped by barges at sea. Besides, interesting biological features such as occurrence of plankton blooms of *Trichodesmium*, have been identified. An enhanced False Colour Composite using a combination of band 4 (red), 6 (green) and ratio of 4/5 (blue) was found most useful in distinguishing between areas under algal bloom and suspended sediments (Balachandran, 1985).

Ocean colour and chlorophyll

Optical oceanography involving researches on water colour originate from shipboard measurements and theoretical studies. Biooptical classification of the water is expressed in terms of chlorophyll-a concentration or total ceton concentration.

By developing an empirical model it is possible for quantification of chlorophyll contents of the waters using radiance ratios for various wave lengths by MSS scanners of LANDSATs. The NRSA Ocean colour Radiometer built under Indo-German Co-operation has six channels with a spectral band width of 11 nm centred about 445, 525, 550, 600, 700

and 750 nm (Muralikrishna, 1983). Using this spectral data an empirical model was developed for quantification of the chlorophyll content.

The CZCS of the American Satellite NIMBUS-7 enables the discrimination between organic and inorganic materials in water and their quantification to a certain extent. Most extensive measurements were made with CZCS multispectral radiometer in all the seas. Dwivedi *et al.* (1985) used NIMBUS 7 CZCS data collected over the Indian Ocean for phytoplankton pigment mapping. Two sub images, one off Cochin and another off Karwar along with

synchronous sea truth data enabled the development of a C-map (Chlorophyll pigment map). From earlier studies conducted in these waters from the fifties it has been possible to quantify the total chlorophyll content for different depth zones. Chlorophyll measurements are indicative of the bioproductivity of the sea. Sea surface chlorophyll has been considered to be significant in the food relations of oceanic fish resources such as tunas since a steady state relationship is possible between the forage of tunas and the chlorophyll through the food chain (Homes *et al.*, 1957). A general chlorophyll map integrated for 0-50 m of the whole Indian Ocean as

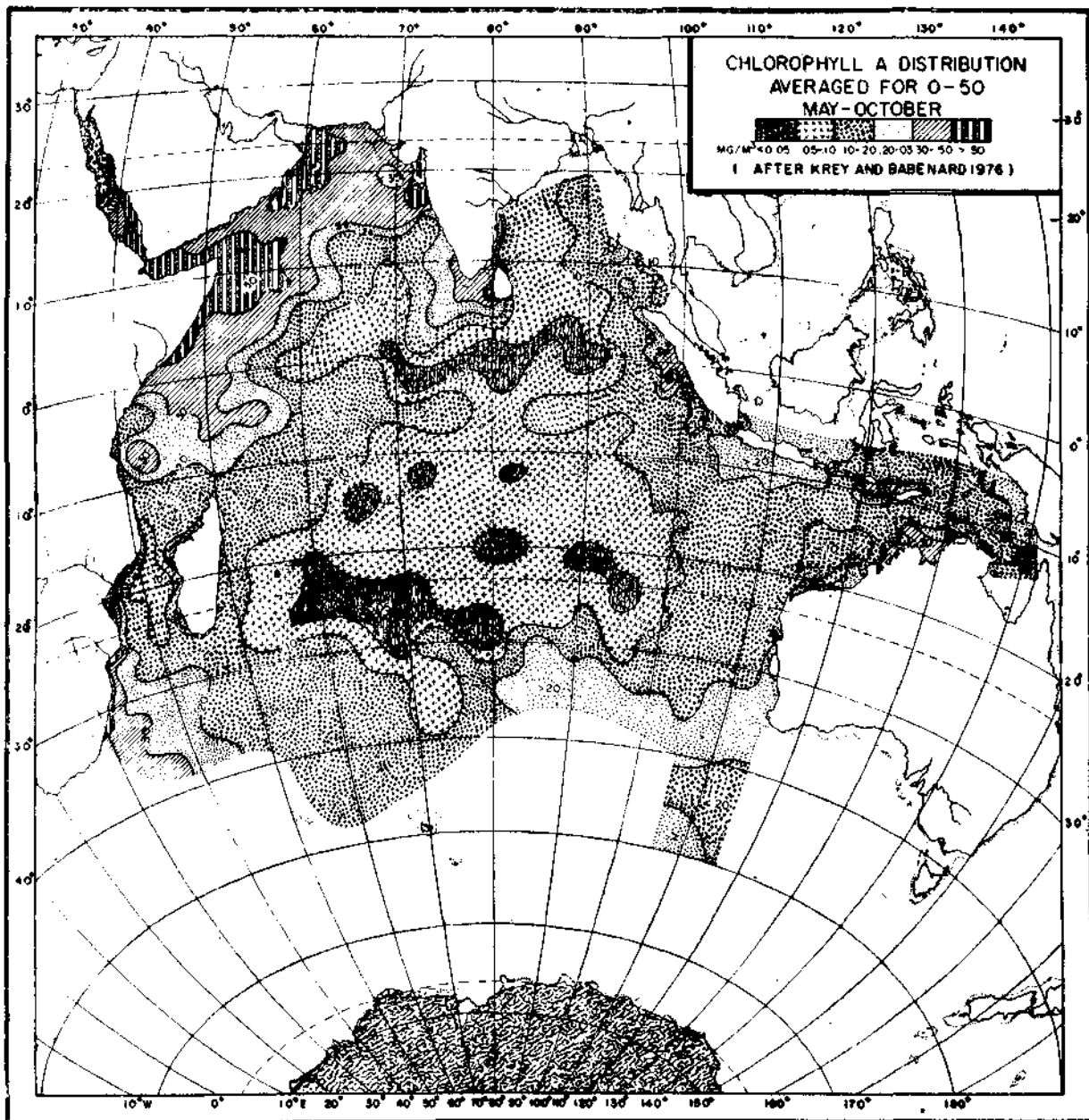

Fig. 1. Chlorophyll map of the Indian Ocean

presented by Krey *et al.* (1976) is given in Fig 1. But it requires intensive study on distribution pattern of chlorophyll both in space and time which will enable the development of models for potential yield data in specific regions. It is in this area that the IRS facility can render repetitive data in shorter time frames on important fishing grounds.

In this connection it is of interest to note that the work carried out by Central Marine Fisheries Research Institute indicated chlorophyll values of 6.4 mg/m^3 during October followed by a sharp fall during November (1.7 mg/m^3) and December (1.4 mg/m^3) when compared with the available fish catch data by FSI for the years 1977 through 1981 showed that the mean monthly fish catch data for October, November and December were directly proportional to the mean quantities of chlorophyll. This suggests that mapping of chlorophyll distribution either from air-borne sensors optimised for ocean colour sensing or satellite scanners combined with sea truth measurements will facilitate a better understanding of the resource potential.

Sea surface temperature and distribution of water masses

The other important area is the thermal infra-red region of the spectrum (3 to 15 μ m) where water at different temperatures emit different amounts of energy which can be measured by sensors operating in that region. SST operation by remote sensing technique will give considerable leeway in weather forecasting so that the fishermen could be warned sufficiently early about the development of tropical cyclones as well as their direction. The SST distribution also contains information on the underlying dynamical processes occurring in the upper part of the oceans such as eddies, warm water currents, upwelling and thermocline. Thermal pollution from large power stations can also be monitored from these information.

Two major phenomena that has significance for fishery oceanographers are upwelling and ocean fronts. The satellite is able to identify specially the location of the upwelling

zones and the timing of their movements which is of great benefit to local fishing operations.

The IR image from satellite can emphasize sea surface temperature difference as white streaks which indicate the presence of cold sea surface water. The sharp contrast between the warm and cold waters can easily be demarcated. Thus other applications of remotely sensed data include structure and synoptic variability of oceanic fronts and major currents, observations on eddies—their formation and evolution, internal waves and precipitation intensity in oceanic areas. Eventually it is hoped that sensors in the microwave region will enable the determination of even salinity through water mass identification.

Future promising areas in Remote Sensing for Marine Fisheries

In conclusion it can be said that in view of its high synoptic potential, the factors monitored using remote sensing technology can be of use for long term prediction of the size of the stocks several seasons away with forecasts available well in advance of fishing seasons so that the fisherman will have the advantage of planning their investments in time and resources before they go to sea. Commercial fisheries involving sedentary species such as oysters and clams, can also benefit from remote sensor technique as these resources are located in fairly fixed stations and hence are extremely sensitive to factors which change the beneficial environment (Lintz and Simonett, 1976). According to Robinson (1985) the most fruitful areas of research are likely to be those in which conventionally gathered data and satellite observations are used to complement each other in order to reveal a fuller perspective of oceanographic process than either of them is individually capable of providing. It is hoped that satellites which are to succeed the present IRS series will have more versatile sensors in infra red and microwave regions in addition to the visible region that would usher in an area in which the entire oceanographic researches could be carried out synoptically from space benefitting the capture fisheries to a large extent by providing inputs

as long-term forecasts on distribution patterns and areas of likely concentrations of fishes.

REFERENCES

- BALACHANDRAN, V. K. 1985. Ocean colour mapping using remotely sensed data. *Project Report, IRS utilization programme on the job training course' Space Application Centre, Ahmedabad.*
- CHAPMAN, W. M. 1969. Implications of space research to fishery development. (in) *The Oceans from Space*, 202-216, Gulf Publ. Co., Houston, Texas.
- GOPALAN, A. K. S. AND SOMVANSHI 1985. Scope of Indian Remote Sensing Programme in Marine living resources survey. *Proc. Seminar on Remote Sensing in Marine Resources, Cochin April 17-18, 1985.*
- HOMES, R. W., M. B. SCHAEFER AND B. M. SHIMADA 1957. Primary production, chlorophyll and zooplankton volumes in the tropical eastern Pacific Ocean *Bull. Inter-Amer. Trop. Tuna Comm.*, 2: 129-156.
- KREY, J. B. BARBERERD 1976. Phytoplankton production—Atlas of the International Indian Ocean Expedition. *Institut für Meereskunde-Kiel University.*
- LINTZ, J. AND D. S. SIMONETT 1976. *Remote Sensing of Environment Addison-Wesley Publishing Co., London.*
- MURALIKRISHNA, I. V. 1983. Chlorophyll scanning experiment in Arabian Sea. *Proceeding of the National Seminar, National Natural Resources Management System, Hyderabad, 10-12 May, 1983.*
- NARAIN, A. AND R. M. DWIVEDI 1985. Optical processes in remote sensing of ocean colour. *Proc. Seminar on Remote Sensing in Marine Resources, Cochin, April 17-18, 1985.*
- NEERA CHATURVEDI, M. CHAKRABORTY, A. NARAIN, G. SUBBARAJU, P. V. R. NAIR, E. G. SILAS, V. S. SOMVANSHI AND K. M. JOSEPH 1985. Phytoplankton pigment mapping from Nimbus-7 CZCS data. *Proc. Seminar on Remote Sensing in Marine Resources, Cochin, April 17-18, 1985.*
- ROBINSON, I. S. 1985. *Satellite oceanography* John Wiley & Sons, New York.
- SILAS, E. G., P. V. R. NAIR, P. P. PILLAI, G. SUBBARAJU, V. K. PILLAI AND V. K. BALACHANDRAN 1985. Biological productivity of the Indian Ocean. *Proc. Seminar on Remote Sensing in Marine Resources Cochin, April 17-18, 1985.*

VALIDATION OF LANDSAT THEMATIC MAPPER-DERIVED PHYTOPLANKTON PIGMENTS THROUGH SYNCHRONOUS SURFACE MEASUREMENTS: AREA OFF CALICUT TO AZHIKAL IN THE ARABIAN SEA

A. Narain, R. M. Dwivedi and H. U. Solanki
Space Applications Center, Ahmedabad 380 053

P. S. B. R. James, G. Subbaraju, V. K. Balachandran,
 A. Nandkumar and L. R. Khambadkar
Central Marine Fisheries Research Institute, Cochin-682 031

D. Sudarsan and T. E. Sivaprakasam
Fishery Survey of India, Bombay 400 001

ABSTRACT

This paper deals with an estimation of phytoplankton pigments from Landsat Thematic Mapper (TM) data after removal of atmospheric effect. The pigments derived from Landsat TM data of October, 1986 and March, 1987 have been compared with corresponding surface values measured during ship cruise programmes synchronous to satellite overpass. In-water algorithm for Landsat TM bands was developed from the sea data collected off Quilon to Malpe in the Arabian sea at different periods of the year. A uniform bias towards underestimation of pigments has been observed in the case of October data and an appropriate modification in the pigment algorithm for Landsat TM has been suggested.

INTRODUCTION

The presence of phytoplankton pigments is associated with algal biomass, forming first link in the marine food chain and therefore remote sensing of phytoplankton pigment abundance provides a useful indication of living resources. An empirical relationship has been observed between chlorophyll pigments and water leaving radiance ratios in visible region of electromagnetic spectrum. This relationship is exploited to estimate pigment from the satellite data. As a first step, the backscattered radiance from water is isolated from the total signal observed at the sensor through elimination of atmospheric scattering effects. Subsequently phytoplankton pigment is estimated with the help of a bio-optical algorithm developed from the sea data. It is desirable to determine absolute values of the pigments with the maximum achievable accuracy if one intends to estimate indirectly the fish stock in a quantitative manner from pigment estimates. An attempt has been made here to compare satellite derived pigments with

the corresponding surface measured pigment values. Aspects related to the accuracy of pigments estimates and probable source of error have been discussed.

Rationale for utilization of Landsat Thematic Mapper data

It has been possible to achieve ocean colour measurements from space with Coastal Zone Colour Scanner (CZCS) (Gordon and Clark, 1980; Gordon *et al.*, 1980; Smith and Baker, 1982; Gordon *et al.*, 1983; Singh *et al.*, 1983; Sturm, 1983; Dwivedi and Narain, 1986) with accuracy goal of estimating pigment concentration within accuracy goal of 0.5 log C (where C is phytoplankton pigment) as set by Nimbus Experiment Team. However, availability of CZCS data is no longer consistent and hence attention of scientists and engineers working in this area has been drawn to Landsat Thematic Mapper (TM), Except for broad bands of TM as compared to CZCS (resulting in loss of sensitivity to detect chlorophyll changes), it has several

advantages over presently available Landsat MSS, in favour of its use for ocean colour mapping. Band 1 (blue-green) and band 2 (green) of TM almost match the maximum and minimum absorption characteristics of chlorophyll-a whereas band 3 and 4 in red and near-infrared are useful for estimation of aerosol scattering effects. Eight bit quantification of signal provides increased radiometric sensitivity and dynamic range. Higher Signal to noise ratio of TM is ideal for detecting very weak signal emerging from oceanic waters. Landsat's morning equatorial crossing time prevents sun glint from entering the sensor's field of view. In view of these technological improvements and regular availability of data, TM appears to be an appropriate substitute till dedicated sensor like Ocean Colour Imager (OCI) or Ocean Colour Monitor (OCM) are available for ocean colour mapping in the distant future. In a preliminary study the application of Landsat TM in phytoplankton pigment mapping has been demonstrated (Kim and Linebaugh, 1985; Dwivedi and Narain, 1986).

METHODS

Sea truth data acquisition and analysis

Sea truth data on phytoplankton pigment and upwelling radiance/downwelling irradiance were collected in the Arabian sea using Turner Designs fluorometer model 10 series and Li-cor make underwater spectroradiometer. Data on above parameters were collected at various sea stations between Quilon (9°N) and Malpe (13° 20'N) in the Arabian sea, off west coast of India. The cruises were timed synchronous to satellite overpass using the vessels viz. RV *Skipjack* (CMFRI) and MV *Matsya Varshini* (FSI). An algorithm developed from regression analysis of the ship data was of the following form.

$$C = 1.62 \left\{ \frac{L(485)}{L(589)} \right\}^{-0.63}$$

where $r = 0.68$; $S_y x = 0.12$ ($n = 18$)

and C is phytoplankton pigment (chlorophyll-a + phaeophytin-a) in mg/m^3 L is radiance in TM band 1 ($C_{\lambda} = 485nm$) and band 2 ($C_{\lambda} = 589nm$).

Approach to digital data analysis

Two scenes of Landsat TM CCT (Path 145, Row 052 of 19 Oct', 1986 and 12 Mar', 1987)

covering oceanic areas off south of Calicut to Kasaragod in the Arabian sea were studied for pigment estimation and its validation. Original TM data were reformatted in band sequential form and compressed to 20 times through resampling. This compression was performed in view of the fact that oceanic features do not change significantly over a large area and spatial resolution of the order of sub kilometer is adequate for the application. Moreover a technique of data compression prior to processing reduces data handling and processing time. A compressed full image obtained by merging of four quadrants (350 pixels x 284 scan lines) thus could be displayed on Comtal image processing system. The data were corrected for atmospheric effects to retrieve water leaving radiance. Spectral radiance $L_T(\lambda)$ received by the sensor can be expressed as:-

$$L_T(\lambda) = L_R(\lambda) + L_A(\lambda) + tL_w(\lambda)$$

where $L_R(\lambda)$ = Radiance contributed by scattering due to air.

$L_A(\lambda)$ = Radiance due to aerosol component.

t = Diffuse transmittance of the atmosphere.

$L_w(\lambda)$ = Radiance backscattered from water.

$L_R(\lambda)$ and $L_A(\lambda)$ were estimated using solar and sensor ephemeris for the central pixel (Dwivedi and Narain, 1986).

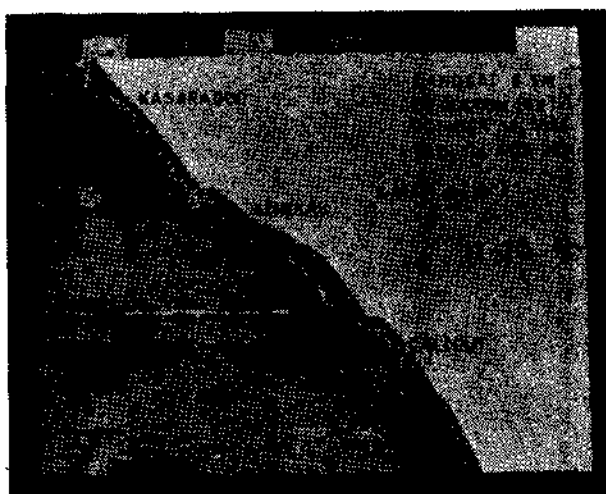

Fig. 1

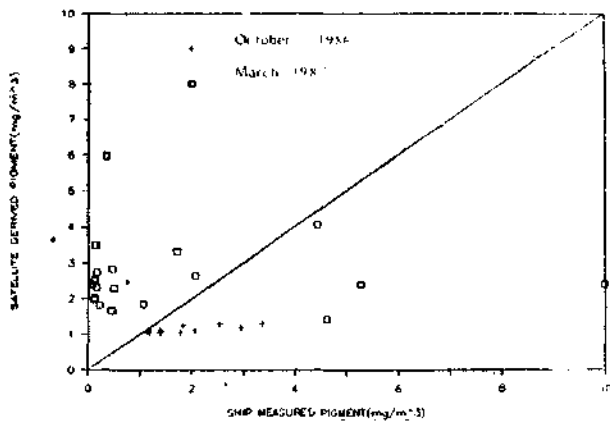

Fig. 2

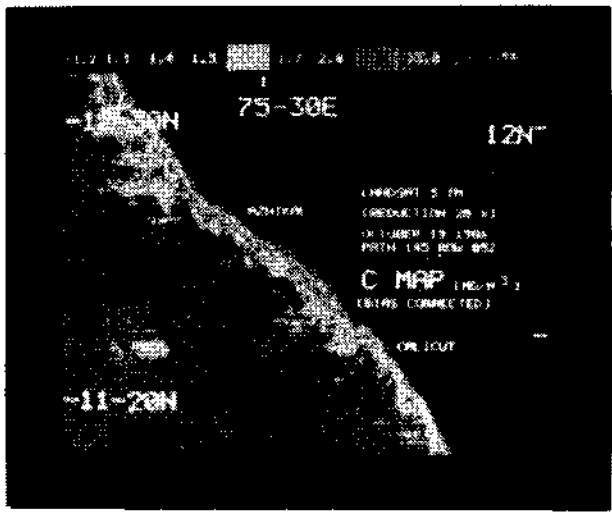

Fig. 3

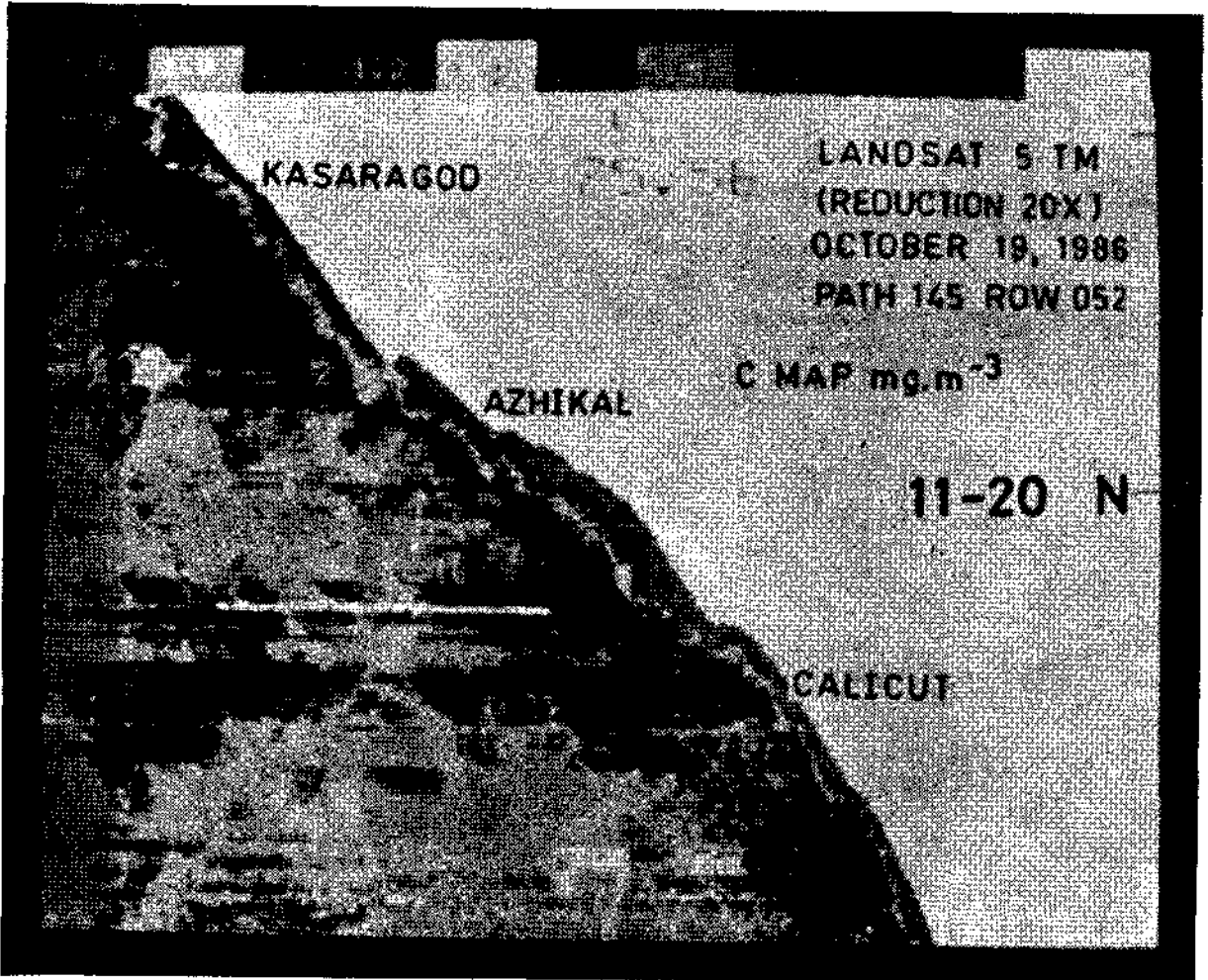

Fig. 4

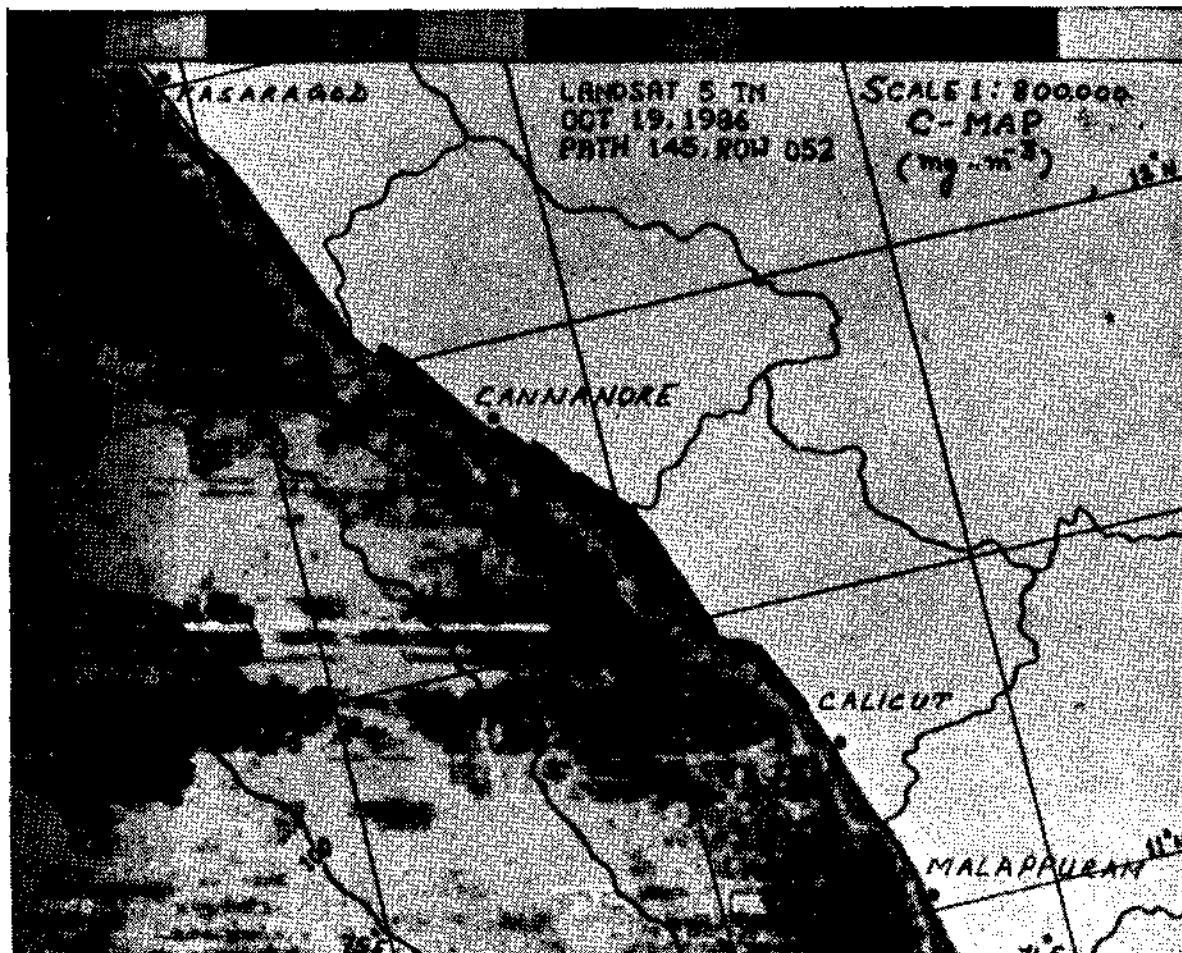

Fig. 5

Comparison between satellite derived phytoplankton and in situ measurements

Sea station corresponding to known surface pigments was located on colour coded map showing spatial distribution of phytoplankton pigment (C map) obtained from TM data (fig. 1). As a next step the pigment values derived from TM data and their corresponding surface values were plotted as shown in fig-2. A 45 degree line was drawn along with the scatter plot for comparison (fig. 2). A uniform bias towards underestimation of pigments was observed in case of October scene whereas the pigment values were uniformly overestimated in case of March scene (fig. 2).

Results and discussion

It appears from figure 2 that TM sensor does not yield reliable estimates for pigment concentration in the range 0-0.5 mg/m³.

In the pigment range of 0.5-2 mg/m³ pigments are uniformly underestimated by a factor of 27 per cent.

In case of C > 2 mg/m³ deviation from 45 degree line is more, probably because in this case chlorophylls act as large particles and contribute more prominently in terms of back-scattering apart from absorption in band 1. Pigments have been found to be underestimated by a factor of 57 per cent in this range.

A set of two factors as mentioned above have been utilized to correct the estimated pigments. Figure 3 shows a colour coded C map with modified pigment values after bias correction.

Conclusions

Landsat TM data do not show sensitivity towards detection of low value chlorophyll

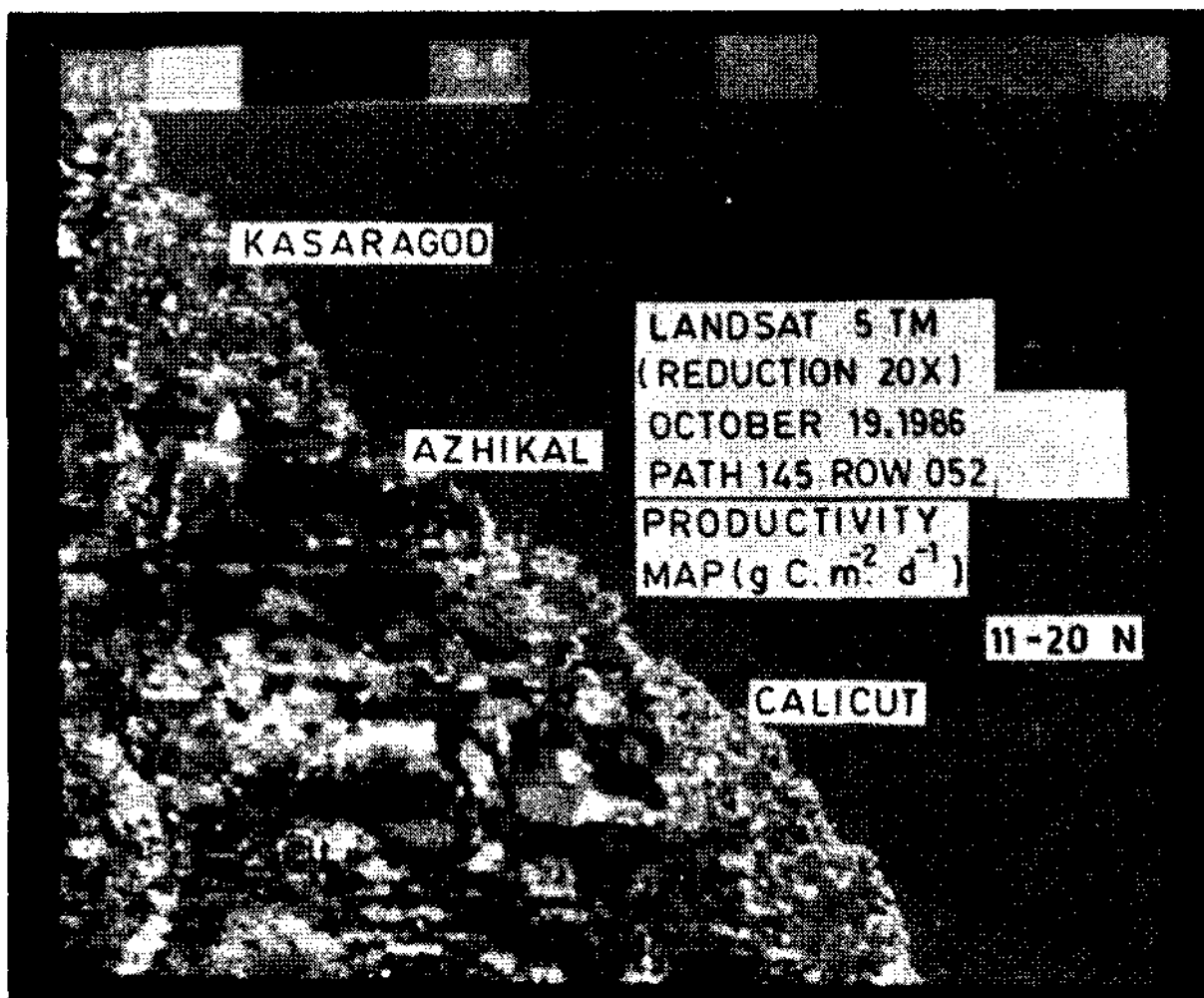

Fig. 6

pigments ($C < 0.5 \text{ mg/m}^3$) obviously because of its broad bands. However, if season dependent algorithm is developed and applied, better estimate of pigments can be made. A bias corrected C map as shown in figure 3 is expected to exhibit realistic values of pigments since the bias is removed with an appropriate correction factor.

Reduction in sensitivity to detect chlorophyll changes due to TM's broad bands is reflected in figure 2. It is seen that variation in chlorophyll pigment concentration is very small. This is because the corresponding estimated radiance ratios show very little change from pixel to pixel.

ACKNOWLEDGEMENTS

We are extremely grateful to the Director General, ICAR, Joint Commissioner (Fishery), Ministry of Agriculture, Shri. P. P. Kale, Director, Space Applications Centre and Dr. Baldev Sahai, Associate Director, IRS-Utilization Programme for their encouragement during the conduct of this work. Thanks are also due to the skippers, engineers and crew members of the research vessels of Central Marine Fisheries Research Institute and Fishery Survey of India.

REFERENCES

- DWIVEDI, R. M. AND A. NARAIN, 1986. Remote sensing of phytoplankton pigment from the Nimbus-7 CZCS: Initial comparisons

with sea truth in the Arabian sea. scientific, note IRS-UP/SAC/MAF/SN/01/86 (Library: Space Applications Centre, Ahmedabad), pp 32-37.

DWIVEDJI, R.M. AND A. NARAIN, 1986. Remote sensing of phytoplankton abundance: An attempt from Landsat Thematic Mapper, Scientific note IRS-UP/SAC/MAF/SN/02/86 (Library, Space Applications Centre, Ahmedabad) 8 p.

GORDON, H. R. AND CLARK, D. K. 1980, Atmospheric effects in the remote sensing of phytoplankton pigments. *Boundary Layer Meteorology*, 18, 299.

GORDON, H. R., CLARK, D. K., MUELLER, J. L. AND HOVIS, W. A., 1980, Phytoplankton pigments from the Nimbus-7 Coastal Zone color Scanner: comparison with surface measurements. *Science*, New York 210, 63.

GORDON, H. R., CLARK, D. K., BROWN, J. W., BROWN, O. B., EVANS, R. H. AND BROENKOW, W. W. 1983. Phytoplankton pigment concentration in the Middle

Atlantic Bight: comparison of ship determination and CZCS estimate. *Applied Optics*, V. 22,20p.

KIM, H. H. AND LINEBBAUGH, G. 1985, Early evaluation of Thematic Mapper data for coastal process studies. *Advances in Space Research* 5, 21.

SINGH, S. M., CRACKNELL, A. P. AND CHARLTON, J. A. 1983. Comparison between CZCS data from 10 July 1979 and simultaneous in situ measurements for south eastern Scottish waters. *International Journal of Remote sensing*, 4, 755.

SMITH, R. C., AND BAKER, K. S. 1982. Oceanic chlorophyll concentrations as determined by satellite (Nimbus-7 Coastal Zone Color Scanner) *Marine Biology*, 66,269.

STURM, B., 1983, Selected topics of Coastal Zone Color Scanner (CZCS) data evaluation in Coastal and Marine Applications of Remote Sensing, edited by A. P. Cracknell (Reading: Remote Sensing Society). p. 137.

THE PRESENT STATUS AND FUTURE PROSPECTS OF ELASMOBRANCH FISHERY IN INDIA

P. Devadoss, M. D. K. Kuthalingam and R. Thiagarajan
Madras Research Centre of C. M. F. R. Institute, Madras-600 105

ABSTRACT

An increasing trend in the annual catch of elasmobranch fishery from 35.6 thousand tonnes during sixties to 53.9 thousand tonnes during seventies and 69.6 thousand tonnes during the current decade (upto 1985) was observed. This increase is mainly due to the large scale mechanisation of the fishery during the seventies. At present, though 65% of the resources is from the west coast, Tamilnadu ranks first contributing 25% of the all India catches.

The optimum levels of effort to get the MSY for sharks and rays using the Schaefer model at selected centres have been worked out and presented. The study has indicated that there is scope for increasing the trawling effort at Visakapatnam, Mandapam and Rameswaram whereas reduction of trawling effort is suggested for Madras, Kakinada, Tuticorin, Calicut and Bombay. The MSY worked out for the gill net at Cuddalore suggested the advisability of increasing the effort whereas a reduction of the effort is indicated for Calicut.

Similarly MSY for sharks obtained in the trawlers at Tuticorin and Nagapatnam indicates the need for a reduction in fishing effort at Tuticorin and increasing the effort at Nagapatnam.

INTRODUCTION

The sharks, skates and rays from one of the important groups of commercial fishes on both the coasts of India which earned a foreign exchange value of Rs. 217.9 lakhs during the year 1984. The average annual production for 10 years 1976-1985 was found to be 58,862 t. These catches are recorded along with different types of gears used mainly for catching other fishes and hence they are found unsuitable for catching larger sharks. As such it can be said that there is no gear available for these groups exclusively.

The resources of this fishery has not so far been highlighted in India, even though it contributes around 4% of the all India catch. Some literature on elasmobranchs worth while mentioning were by Setna and Sarngdhar (1946 and 1949). James (1973) summarised the available information on this group in India. Subsequently, Devadoss (1977, 1978 a and b, 1979, 1984 a and b) studied on some aspects of the biology and fishery of few species of this group.

In this paper* an attempt has also been made to throw light on the possibility of increasing or decreasing the fishing effort to achieve the maximum sustainable yield all along the coasts.

ALL INDIA ELASMOBRANCH PRODUCTION

For the 25 year period 1961-1985 the elasmobranch catches fluctuated between 29,401 t (1967) and 69,844 t (1983) with the annual average of around 50,159 t. There is sharp increase in the average catch of this group from 35.6 thousand tonnes during sixties to 53.9 thousand tonnes during the seventies and in eighties upto 1985 it reached the peak contributing 69.6 thousand tonnes (CMFRI, 1982, 1983 and 1986). Figure 1 depicts for the period 1961-1985. The increase in the landings was very much notable from 1974 onwards. The catch during 1973 was 44,917 and increased to 66,054 t during 1974, showing an increase of 47% over that of 1973. It is also observed that the catches were more or less steady and never

* This formed part of the thesis for the degree of Ph. D of Annamalai University by P. Devadoss

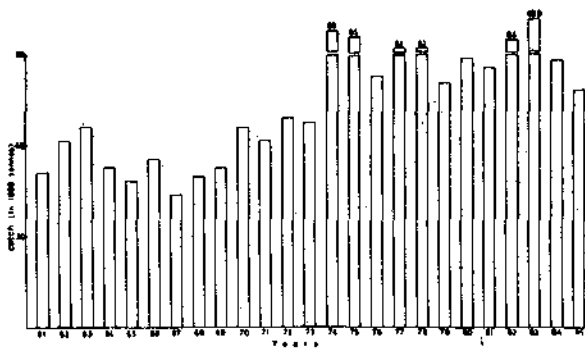

Fig. 1. Annual landings of elasmobranchs for the years 1961-1985

fell below 52 thousand tonnes. This increase in the catch is due to the significant increase in mechanised fishing effort and rapid development in the infrastructural facilities for the fishing industry as a whole.

The major species contributing to the fishery consists of *Carcharhinus sorrah*, *C. limbatus*, *C. dussumieri*, *C. melanopterus*, *C. marcloti*, *Geleocerdo cuvier*, *Hemipristis elongatus*, *Scoliodon laticaudus*, *Loxodon macrohinus*, *Rhizoprionodon acutus*, *R. oligolinx*, *Isurus oxyrinchus*, *Sphyrna blochii*, *S. lewini*,

S. mokarran, *Rhynchobatus djeddensis*, *Rhinobatus granulatus*, *Rhina ancylostoma*, *Dasyatis sephen*, *D. uarnak*, *D. imbricatus*, *D. marginatus*, *D. alcockii*, *Aetobatus narinari*, *Aetomylus nichofii*, *A. maculatus*, *Rhinoptera javanica*, *Gymnura poecilura* and *Mobula diabolus*. Some appear casually in the fishery and these include the whale shark, cat sharks, Saw fish and electric rays.

TREND OF PRODUCTION ALONG THE EAST AND WEST COASTS

For the ten year period 1976-1985, the annual average elasmobranchs landed from the east and West coasts was 25,603t (43.5%) and 33,258t (56.5%) respectively (Table 1). It will be seen that the total catch shows considerable fluctuations in both the coasts. Unlike other fisheries which reveal a pattern of 25:75 for the east and west coasts respectively, elasmobranch fishery has showed no such marked variations between both the coasts (Fig 2).

TABLE 1.

Trend of elasmobranch production along the east and west coasts of India during 1976 - 1985

Year	Catch in East coast		Catch in West coast		Total	Increase/decrease
	Catch (tonnes)	Increase/decrease over previous year (%age)	Catch (tonnes)	Increase/decrease over previous year (%age)		
1976	29,431		25,174		54,605	
1977	26,950	- 8.4	35,266	+40.1	62,216	+13.9
1978	27,624	+ 2.5	33,997	- 3.5	61,621	- 0.9
1979	24,272	-12.1	28,571	-15.9	52,843	-14.2
1980	25,661	+ 1.6	33,201	+16.2	57,862	+ 9.5
1981	22,704	- 7.9	33,305	+ 0.3	56,009	+ 3.2
1982	24,231	+ 6.7	40,085	+20.4	64,316	+14.8
1983	31,489	+30.0	38,355	- 4.3	69,844	+18.6
1984	24,845	-21.1	32,796	-14.5	57,641	-17.5
1985	19,825	-20.2	31,834	- 2.9	51,659	-10.4
Total	256,032		332,584		588,616	
Average	25,503		33,258		58,862	
Percentage	43.5		56.5		100.00	

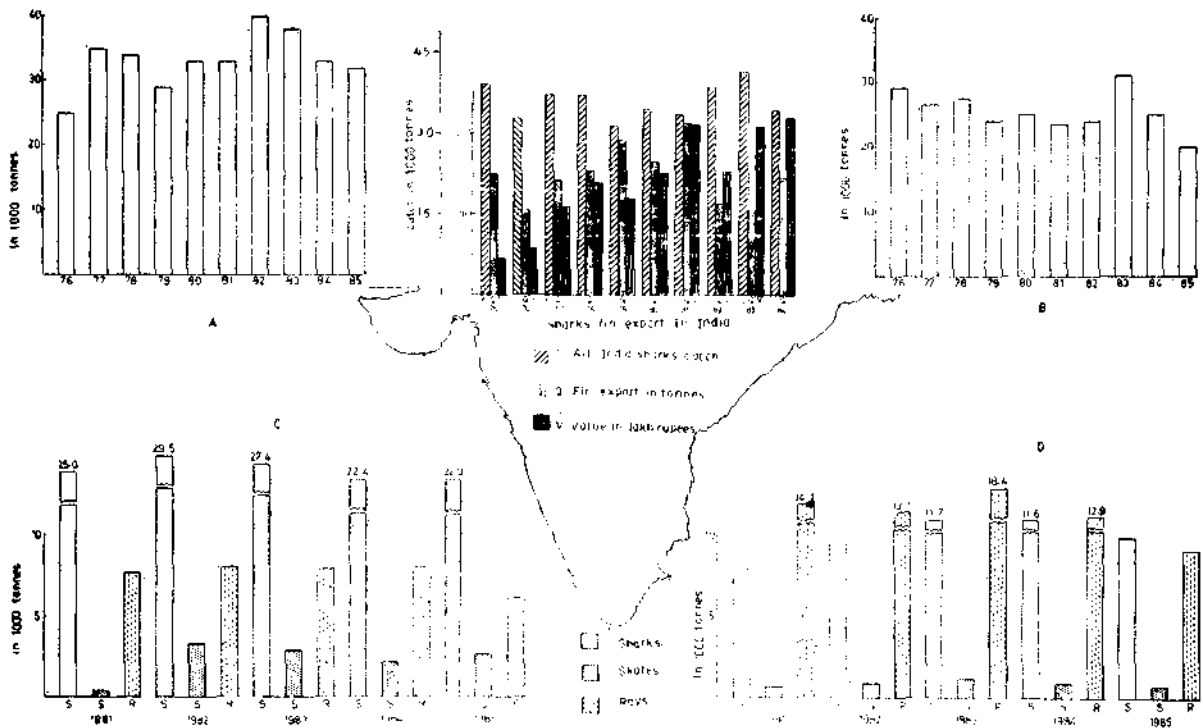

Fig. 2. Elasmobranch production along the east and west coasts of India and export figures for shark fins. A. Elasmobranch catch during 1976-1985 on the east coast B. Elasmobranch catch during 1976-1985 on the west coast C. Trends in catch of sharks, skates and rays in 1985 on the west coast. D. Trends in catch of sharks, skates and rays in 1984-1985 on the east coast.

DETAILS OF STATE-WISE PRODUCTION

The state-wise average production of elasmobranchs is shown in figure 3. The estimated catch for the ten year period, 1976-1985 revealed that Tamilnadu ranked first with an average landings of 14,783 t which constitutes 25% of the total elasmobranch landings of

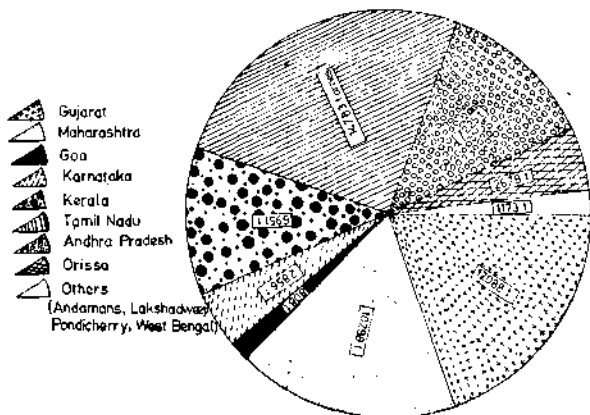

Fig. 3. Contribution of elasmobranchs from the maritime states and union territories.

India. Gujarat with 12,088 t ranked second forming 20.5%. West Bengal contributed a dismal 0.7% of the catch. The Union Territories

of Pondicherry, Andamans and Lakshadweep together contributed 1.2%. While fishes almost all round the year as incidental catch, in Tamilnadu and in certain parts of southern Andhra Pradesh a specialised bottom fixed net for rays and skates is operated during September, October and January to March period when large quantities of rays and skates are landed.

It is noted from the data furnished that the increased production in the year 1983 may be attributed mainly to the increased landings from Tamilnadu, Kerala and Maharashtra. While the fishery showed fluctuating trends in almost all the states like Andhra Pradesh, Maharashtra and Gujarat produced a definite pattern of catch. Andhra Pradesh recorded an increasing trend in recent years—1983, 1984 and 1985 as Gujarat reached maximum catch during 1980-1982 and Maharashtra during 1982 and 1983.

GROUP-WISE LANDINGS

Analysis of data for the period 1981-85, presented in table 2 in respect of three major groups, sharks, skates and rays, revealed the

TABLE 2.

All India landings of sharks, skates and rays (In tonnes)

Year	Sharks		Skates		Rays		Total
	West coast	East coast	West coast	East coast	West coast	East coast	
1981	25,184	7,927	397	661	7,063	14,777	56,009
1982	29,568	10,196	2,422	923	7,142	14,065	64,316
1983	27,455	11,772	2,916	1,288	7,981	18,429	69,844
1984	22,455	11,064	2,254	861	8,087	12,920	57,641
1985	22,910	9,825	2,716	799	6,208	9,201	51,659
Total	127,527	50,786	10,708	4,532	36,481	69,392	299,469
Average	25,552	10,157	2,142	906	7,296	13,878	59,894
Percentage	71.5	28.5	70.3	29.7	34.4	55.6	—

dominance of sharks in all years (fig 2). Sharks contribution during the five years, works out on an average to 59.6%, followed by rays 35.3% and sharks 5.1%. West coast emerged as centre for sharks fishing (71.5%) as east coast for rays (65.6%) as shown in table 2. Even though the contribution by sharks was not impressive, 70% of them were landed from west coast. The peak landing was noticed during 1982 and 1983 for sharks and 183 for rays and sharks. The following years, 1984 and 1985 recorded a declining trend. Species of gray sharks *carcharhinus* dominated the sharks catch with 70-75%, while *Dasyatis* formed 68% of the rays and skates fishery at Calicut (Devadoss, 1984).

GEAR-WISE CATCH

Elasmobranchs are landed mainly by gill nets and trawls. Hooks and line also is used some times, but the catch is negligible. Gearwise landing estimated for the period 1981-85 are presented in table 3. Since particulars of catch are not available for all the centres, details are projected only from all centres. Trawlers landed 80% of the elasmobranchs, while gill nets' contribution was 19%, the remaining by other units.

At Visakapatnam and Kakinada rays and skates formed 90% and 87% respectively of the elasmobranchs landed by trawl (fig.4) Rays and

skates also dominated the elasmobranchs landed by trawlers at Madras, Nagapatnam, Mandapam, Rameswaram and Tuticorin with 65-100% and sharks formed 70-90% among the elasmobranchs from gill net catches of these centres. The Major centres of Kerala, Sakthikulangara, Cochin and Calicut accounted for more than 90% sharks in the elasmobranchs landed by gill nets, while rays and skates shared 85% of elasmobranchs landed by the trawls. The same trend is noticed at Veraval and New ferry wharf of Bombay, but the catches at Bombay's sasoon dock and Mangalore revealed the dominance of sharks from both the gears, whereas at Tuticorin the gill net catches of elasmobranchs showed 50% by skates and rays.

The catch trend appeared to show Sakthikulankara, Cochin, Calicut and Mangalore as centres of shark fishing (drift gill net), and other centres for rays and skates (trawl).

ESTIMATION OF SUSTAINABLE YIELD (MSY)

Based on the recent years catch and effort for sharks and rays from the mechanised trawls and gill nets the surplus production model i.e. Schaffer model (Ricker, 1975), the maximum sustainable yield (MSY) and the optimum level of effort to get the MSY was estimated in major centres of India. The percentage contribution of sharks, skates and rays, cpue and total catch of

TABLE 3.

Percentage contribution of sharks, skates and rays; catch per unit effort and total catch of elasmobranchs in trawls and gill nets (in parenthesis)

Centres	Sharks %	Skates %	rays %	CPUE (kg)	Total catch (t)
Visakapatnam	10	28	62	4.3	126
Kakinada	13	16	71	8.9	384
Madras	35	12	53	8.7	259
Cuddalore	71	5	24	39.4	68
Cuddalore	(90)	(0)	(10)	(179.1)	(252)
Nagapatnam	7	2	91	13.2	344
Mandapam	0	0	100	5.4	242
Pamban Palk Bay	(54)	(0)	(46)	(6.7)	(70)
Pamban Gulf of Mannar	(90)	(0)	(10)	(17.0)	(118)
Rameswaram	0	0	100	31.8	2,930
Tuticorin	34	0	66	17.2	601
	(50)	(0)	(50)	(8.5)	(4)
Sakthikulangara	11	0	89	2.3	349
Cochin	(94)	(1)	(5)	(62.1)	(645)
Cochin	12	11	87	1.2	58
	(95)	(1)	(4)	(23.2)	(434)
Calicut	15	0	85	7.1	33
	(97)	(0)	(3)	(35.3)	(107)
Mangalore	70	0	30	1.3	49
	(100)	(0)	(0)	(16.7)	(47)
Bombay Sasson Docks	64	10	26	67.8	1589
	(72)	(7)	(21)	(79.8)	(309)
Bombay New Ferry Warf	33	29	38	182.1	3,496
	(90)	(0)	(10)	(68.0)	(10)
Veraval	23	25	52	—	965
	(78)	(0)	(22)	(—)	(425)

elasmobranchs in trawl net and gill net are given in table 3 for different centres. In general rays dominates trawl catch except in centres of Bombay and Mangalore where sharks contributed 64% and 70% respectively in the elasmobranchs catch. But in gill netters shark formed the major portion. The present (1980-85) annual average catch, effort and cpue and estimated MSY, sharks and rays in different centres are given in tables 4 and 5. The salient features are discussed centre-wise.

Visakapatnam: At the Visakapatnam outer harbour during the years 1980-85 the average elasmobranch catch by trawl was 126 t the cpue being 4.3 kg. The percentage of sharks, skates and rays was 10, 20 and 62 respectively. The number of operations varied between 27 and 35 thousands. The estimated MSY for rays was 166 t and for sharks 14 t. As the present catch of rays and sharks were 78 t and 13 t, there is much scope for increased trawl effort for rays.

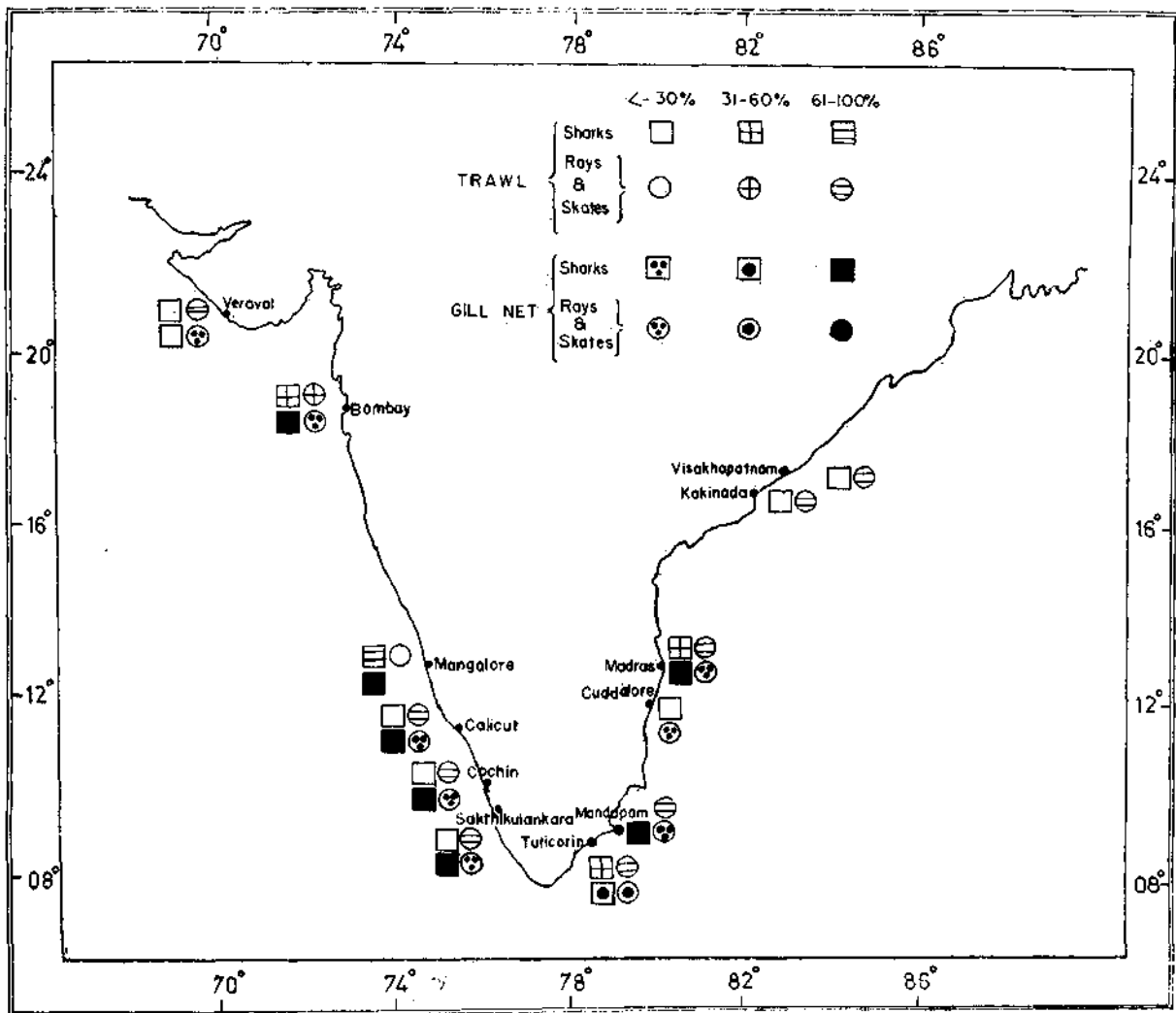

Fig. 4. Distribution pattern of sharks, skates and rays at selected centres.

Kakinada : The contributions of elasmobranchs by trawl ranged between 310 and 469 t with an average of 384 t. Rays contributed 71% and skates and sharks 16 and 13% respectively. The estimated MSY for rays and sharks were 305 t and 44 t as against the present average of 274 t and 40 t landed respectively. To obtain the MSY for rays, a reduction of 23% and for sharks an increase of 10% effort is suggested. The present average effort was 31 thousand trawl operations.

Madras : Trawlers landed 83-560 t of elasmobranchs with an average of 259 t and a cpue of 8.7 Kg. Rays formed 53% and sharks 35% and skates 12%. In gill netters the contributions of sharks, skates and rays 71%, 24% and 5% respectively of 68 t of the average catch. The estimated MSY for rays in the trawl catch and gill net were 167 and 31 t respectively as

against the present average landings of 135 t of rays and 16 t of sharks. To obtain the MSY, a reduction of 19% trawl effort and an increase in gill net effort of 93% is advised. The present average catch of sharks were 111 t and 48 t from trawlers and gill netters and the calculated MSY were 154 t and 64 t. An increase of 103% and 98% of trawl and gill net efforts is necessary to obtain the MSY of sharks.

Nagapatnam : The elasmobranchs catch fluctuated from 78 t to 605 t with an average of 344 t by trawlers. Rays and sharks contributed 90% and 7% respectively with an average cpue of 12.0 kg and 0.8 kg. The annual average catches were 319 t for rays and 19 t for sharks. The estimated MSY for sharks was found to be 21 t.

Cuddalore : The gill net fishery contributed 95-550 t of elasmobranchs, the annual average

being 252 t and cupe 159 kg. Sharks formed 90% and the rest by rays. The MSY for sharks and rays were 375.27 t and an increase of 3% effort for sharks and 23% for rays is possible to get the MSY.

Mandapam: Among the elasmobranchs rays dominated the catch in trawlers which fluctuated between 209 and 332 t. The MSY for rays was 419 t as against the present catch of 242 t average. An increased effort of 182% is recommended to obtain the MSY.

Remeswarum: Rays contributed the entire elasmobranch catch by trawlers which fluctuated between 2330-3453 t with an average annual catch and cpue of 2930 t and 31.8 kg respectively. The MSY calculated was 4042 t suggesting an increased effort of 108%.

Pamban: The indigenous drift gill nets from Palk Bay and Gulf of Mannar contributed an average annual catch of 70 and 118 t respectively during the years 1970-76. Sharks formed 90% from the Gulf of Mannar and 54% from the Palk Bay and the rest by rays. The average cpue of gill net for sharks was 15.2 and 2.6 kg.

Calicut: During the years 1971-80 the elasmobranch catch by trawlers fluctuated between 14-67 t, the average annual catch being 38 t. Rays formed 85% and sharks 15%. The MSY for rays was 41 t and the effort required was only 5 thousand as against the average catch of 33 t 6 thousand boat day operations. So a reduction of 19% trawl effort is necessary to get the MSY. The average gill net catch was 104 t, sharks forming 97%. Here also a reduction of 7% effort is advisable.

Bombay: At Sassoon dock, the annual average catch by trawlers was estimated as 1587 t during the period 1980-85. Sharks contributed 64% and skates and rays 10% and 26% respectively. Gill net landed an annual average catch of 309 t of which sharks, skates and rays contributed 72%, 7% and 21% respectively. To achieve the MSY of 618 and 75 t from trawl and gill net as against 416 and 65 t a reduction of trawling effort is necessary. In regard to gill net an increase of 57% effort is needed to get the MSY of 256 t of sharks from the present level of 214 t. At New Ferry Wharf, trawlers

landed an annual catch of 3496 t of elasmobranchs with a cpue of 182 kg, sharks, skates and rays contributing 33%, 29% and 38% respectively. Gill nets landed 9 t of sharks annually.

Veraval: During the years 1983-84 and 1984-85 trawlers landed 956 and 974 t of which sharks, skates and rays formed 23%, 25% 52% respectively. Gill nets landed 276 and 574 tonnes during the same period of which sharks shared 78% and the rest by rays.

NOTES ON THE BIOLOGY OF SOME IMPORTANT SPECIES

Sharks of the family carcharhinidae are the most important groups dominating the fishery all over the world. Similarly *Carcharhinus* formed the bulk of the catches of our coasts also. The following species are commonly reported in the Indian coasts.

Carcharhinus limbatus: This shark is cosmopolitan in distribution in the inshore regions of tropical waters. It is capable of tolerating reduced salinities, but never penetrates into fresh water. Feeds primarily on fishes like sardines, mackerels, croackers and soles; cephalopods and crustaceans are also taken. Devadoss (1977) recorded that mackerels formed the main diet during the mackerel season, April-June at Porto Novo. Grows to maximum of 2.5 m. Males mature at 140-150 cm and females at 150-160 cm producing an average of 6 embryos per litter and the size at birth is 55-60 cm. They are usually caught in drift gill net, hooks and line and bottom set net.

C. sorrah: This is also a common shark fished along the coasts of India and it often frequents coral reefs. A short and sturdy species, it grows to around 1.5 m. Feeds on bony fishes like mackerels, flying fishes, sardines, squids and prawns. Males mature at 115 cm and females at 120 cm (Devadoss, 1977). Litter size is 2-6 young and size at birth is 40 cm when they are delivered during March-May in Indian coasts.

C. dussumieri: A small, common species of shark in the inshore waters, often confused with its closely resembling cousin *C. sealie* (= *C. Meni sorrah*). Feeds on small fish squids and

crustaceans. It grows to a meter long; males maturing at 65 cm and female at 76 cm. Size at birth is 35 cm. Breeding throughout the year in East Indies (Teshima and Mizue 1972). Development, viviparous method, having a litter size of 2 embryos

C. melanopterus: A wide ranging Indo-pacific tropical shark and is capable of migrating into estuaries and brackish water for the purpose of delivering their pups. Grows to 2-2.5 m. Young ones just born with fresh umbilical scar, 45-50 cm in total length were often recorded during November-December in the estuary of the river Chaliyar, South of Calicut city. The young were taken in the gill net set with in a kilometer range from the river mouth. Feed includes a variety of fishes like mullets, silver bellies, anchovies, hilsa, skates, prawn and *Squilla*. It is commonly fished by drift gill net and long line.

C. macroti: A small medium sized shark grown upto a little over a meter in length. Fished by drift gill net and hooks and line, marketed fresh, sometimes salt-dried. Its diet consists of small fish, crustaceans and squids. Males mature at 60 cm and females at 70 cm producing 2 young per litter, young measure 35 cm at birth.

Galeocerdo cuvieri: The largest recorded measured 740 cm. A widely distributed tropical shark capable of cruising in mid ocean. It shows nocturnal movement into bays and estuaries. Feed includes a wide variety of marine and terrestrial form. Fishes eaten included all kinds, eels, cat fishes, parrot fishes, flat fishes, flat heads, flying fishes, porcupine fishes, puffers, skates and rays. Marine reptiles eaten are sea turtles, green logger heads and ridley turtles. Even sea snakes are not spared. Sea birds including cormorants and pelicans are other items of the diet. Marine mammals taken by this shark are sea lions, seals and dolphins, carrion from terrestrial birds and mammals is common. Inanimate objects which may be accidental inclusions in their stomach are leather bags, pieces of coal and wood, cans and small barrels.

Tiger shark is one of the dangerous sharks known for attacking divers and swimmers and boats. Among tropical sharks tiger shark has worst reputation as man eater.

Development is ovoviviparous, litter size is very large, 10-82 and size at birth is 50-75 cm. Popping is reported in November - January in Bombay waters (Sanagdar, 1944).

Scoliodon laticaudus: An abundant species in west coast and southern part of east coast of India. It is very rare in the North Tamil nadu coast. It grows to 65 cm but majority of males grow up to 50-55 cm and female up to 65 cm. This is mainly caught in trawl. But those caught in drift gill net are females above 50 cm. Maturity at 30 cm and 35 cm for males and females respectively. Development is viviparous with yolk sac placenta, breeding almost throughout the year, and produces upto 20 embryos per litter. Size at birth is 14.5 cm. Food consists of small fishes, crustaceans and squids.

Rhizoprionodon acutus: A medium sized shark in the inshore regions, grows to a little over one meter. It is more abundant in west coast during September to February and in East coast during summer months. Feeds on small fishes, squids and cuttle fish, crabs and shrimps. Viviparous mode of development with yolk sac placenta. Number of young varies from 2-6. Parturition takes place during summer months on the east coasts, size at birth is 26-27 cm.

Next to grey sharks, hammer head sharks form a sizable fishery. Of the four species recorded. Only *Sphyrna lewini* is very common. *S. blochii* and *S. mokarran* are less important.

S. lewini: This is most common hammer head shark in our coasts. A highly migratory form found in the tropical region of the oceans. Instances of sexual segregation are reported. Feeds on fishes like sardines, anchovies, mackerel, eels, milk fish, soles etc. Sharks and rays are also eaten. Development is viviparous with yolk-sac placenta and a litter size of 15-30 pups. A maximum of 20 pups was observed (Devadoss 1977) in our coast. The size at birth is 45-55 cm and grows to 4.2 m.

Saw fish: - *Pristis microdon* and *P. cuspidatus* are sporadically caught. The former is reported to grow to 25 feet but actually specimens upto 5 m are often met with. The season for the saw fish fishery is during March - September in the east coast, gravid females were caught during

TABLE 4.

Annual average catch, effort and CPUE for the years 1980-85 and estimated MSY, effort (fmsy) and catch per effort (Y.f) for rays in trawl (T) and gill net (G) catches in different centres.

Center	Name of Catch Unit	catch (t)	Effort (x 1000)	CPUE (kg)	MSY (t)	f msy (x 1000)	y/f (kg)	Effort to MSY
Visakapatnam	T	78	31	2.6	234	166	1.4	+ 442%
Kakinada	T	274	40	7.0	305	31	9.9	- 23%
Madras	T	135	32	6.0	167	26	6.6	- 19%
	G	16	2	11.9	31	4	7.8	+ 98%
Nagapatnam	T	319	26	12.0	—	—	—	—
Cuddalore	G	19	2	11.1	27	3	9.1	+ 26%
Mandapam	T	242	45	5.4	419	127	3.3	+ 182%
Rameswaram	T	2530	93	31.8	4042	193	20.9	+ 108%
Tuticorin	T	321	40	8.8	462	27	17.4	- 33%
Sakthikulangara	T	312	132	2.3	—	—	—	—
Calicut	T	33	6	6.3	41	5	8.1	- 19%
	G	2	3	0.8	2	3	0.9	- 7%
Bombay Sassoon Dock	T	416	22	18.6	618	14	43.2	- 36%
	G	65	4	17.2	75	3	25.7	- 26%
Bombay New Ferry Wharf	T	1666	24	70.3	—	—	—	—

TABLE 5.

Annual average catch, effort and CPUE for the years 1980-85 and estimated MSY, effort (fmsy) and catch per effort (y/f) for sharks in trawl (T) and Gill net (G) in different centres.

Centre	Name of unit	catch (t)	Effort (x 1000)	CPUE (kg)	MSY (t)	f msy (x 1000)	y/f (kg)	Effort to MSY
Visakapatnam	T	13	31	0.4	14	33	0.4	+ 6%
Kakinada	T	48	40	1.2	50	44	1.1	+ 10%
Madras	T	111	32	3.5	154	65	2.4	+ 103%
	G	48	2	25.6	64	4	17.1	+ 90%
Nagapatnam	T	19	26	0.8	21	29	0.7	+ 38%
Cuddalore	G	226	2	165.5	375	2	161.1	+ 3%
Tuticorin	T	280	40	7.0	379	26	14.6	- 35%
Sakthikulangara	T	38	132	0.3	—	—	—	—
Calicut	T	5	6	0.8	—	—	—	—
	G	31	3	10.3	—	—	—	—
Bombay Sassoon Dock	T	1018	22	45.4	—	—	—	—
	G	214	4	56.9	256	6	41.8	+ 57%

May - July when they move shoreward for delivering their pups.

Other Skates: *Rhynchobatus dieddensis* and *Rhinobatus granulatus* are commonly fished. *R. dieddensis* grows to more than 3 m and mature at 1.5 m. Females carry full term embryos in the uterus as well as fully developed ova 10-12 cm in the ovaries at the same time. Upto 12 embryos in a litter were recorded at Madras. Feeds on fishes, prawns, molluscs and polychaete worms. Fishes included apogonids, juvenile eels, thread fins and flat heads. Highly priced among sharks and skates, its fins have good export value. *Rhinobatus granulatus* grows to 2.5 m in our waters. The smallest female with developed ovary and large ova measured 120 cm. Mature ova and full term embryos exist at the same time inside a female suggesting a quick succession of ovulation and fertilization after birth of young. The maximum of 14 embryos observed were equally distributed in both uteri. It has an extended breeding season, gestation period is about 6 months. Feeds on small crustacean like amphipods, *squilla*, small crabs and prawn.

Rays: Among the rays the species of *Dasyatis* dominate the fishery. Besides, other groups of rays like *Aetobatus*, *Aetomylus* and *Rhinoptera* also form an occasional fishery. *Dasyatis unanek* is a large ray the maximum recorded by the authors at Madras measured 1.8 m. A predator, it causes extensive damage to the fishery. Feeds on a wide variety of fishes and other animals (Devadoss, 1978). For instance one ray had consumed about 140 nos. of prawns, fishes, crabs, *Squilla*, *Thenus* squids, gastropods, bivalve and jelly fish. *D. sephen* is another large and heavy ray which grows to more than 1.6 m. Males mature at 70 cm and females at 80 cm. Development is by ovoviviparity without any yolk-sac placenta. Litter has 2 embryos and the size at birth is 25 cm across disc. The diet consisting of crustaceans, molluscs and fishes. Polychaete worms are also preferred (Devadoss, 1978). *D. alcockii* grows to moderate size of around 1.25 m. This ray feeds on polychaetes, crustaceans, molluscs and sea squirts. *D. imbricatus* is the smallest among the sting rays and is common in our coasts. It is a bottom feeder, feeding on small burrowing and buried

crustaceans and polychaetes (Devadoss, 1984 a). It develops both ova and embryos simultaneously. Breeding extends over a period of six months producing one to two young per litter by ovoviviparous mode with a size at birth of 75 mm. It grows to 22 - 23 cm and maturity is determined at 16.0 - 17.0 cm for males and 17.0 to 18.0 cm for females. *D. zugei* is another smaller ray which grows to 26.0 to 30.0 cm and is fished along with *D. imbricatus* by trawl.

***Aetobatus narinari*:** A tropical species of Indo-Pacific and Atlantic oceans, this ray is fished by gill net and trawls. It is capable of making extensive journeys across the open sea. Generally known to grow to 6 feet across disc (Wallace, 1967) but a female measuring 225 cm was caught at Madras. The males mature at a size of 135 cm and females at 150 cm across disc respectively. Produce three embryos and the size at birth is 250 mm. The diet consists of clams, oysters and *perna*.

***Aetomylus nichofii*:** Indo-Pacific in distribution, this ray has the habit of migrating to salt lakes, estuaries and backwaters. It grows to around 2 m in Madras and upto 3 embryos were recorded in a litter and size at birth ranges 200 - 235 mm. Feeds on crustaceans like *Thenus*, *Acetes* other prawns and crabs, teleostean fishes are also included. Apogonids, *Nemapterus* and soles, squids and gastropods formed a considerable portion of the diet.

***Rhinoptera javanica*:** The species forms an occasional fishery during November to March on the east coast, September to April on the west coast. Often huge shoals of this ray with a size of 150 cm have been exploited in the near shore region. It is said to make disastrous raids on the pearl oyster beds in the Gulf of Mannar between November and February when the oysters are in full maturity stage (James, 1973). Females outgrow males and no male is observed to grow more than 150 cm during our observations. Females grow over 170 cm. Female around 100 cm are seen carrying embryos. The size at birth is 30 cm.

REMARKS

It is evident from the data gathered and presented in the text that the west coast ranks

high in shark production. This abundance has been correlated with the availability of pelagic fish stock like, sardines and mackerel during the period of September - November. Devadoss (1977) pointed out that pelagic sharks like *C. limbatus* and *C. sorrach* were actively feeding on these fast moving pelagic shoals. The appearance of sharks is very often noted in the east coast during April-September during which period mackerel and sardines occurred in plenty in the commercial catches. It is also observed that the pupping season for sharks of different species coincides with this, from September on the east coast. The carnivorous nature of feeding of the adults is well seen in the life of young sharks and rays also. An interesting observation on shark landings is that though sharks were obtained in all the traditional gears used for fishing, more than 80% of sharks were contributed by gill nets.

Catch statistics worked out reveals the possibility of the existence of a rich ground for pelagic sharks off the coast of Bombay, Mangalore, Calicut, Cochin and Sakthikulankara, and for Skates and rays off Visakhapatnam, Kakinada, Madras, Mandapam and Tuticorin. So rays and skates of east coast constituted 65.6% of the national resources of elasmobranchs. Here also the availability of rays is closely associated with the variety of demersal fisheries. Since the rate of reproduction in rays is extremely low, maximum caution should be observed in exploitation. For it is likely that the rays may not withstand such a high degree of exploitation. It is evident that more trawling effort had been concentrated in most of the centres, as a result the catches declined considerably. So it is suggested that a reduction effort is highly essential to maintain the MSY.

It is seen from the figures presented that sharks fins are one of the contributors for foreign exchange which steadily showed an increase from Rs. 44.3 lakhs in 1976 to Rs. 217.9 lakhs in 1984. it is also interesting to note that quantity of fine exported remains more or less constant over the years and increase in price is only due to the increased market value of the fins and not due to any increase in the quantity.

There is plenty of scope for increasing the shark fishing in India by an increase in gill net

operations which is clearly shown from the data presented from Bombay, Madras and Calicut. The bottom set gill net used for catching rays in Tamilnadu and parts of Southern Andhra coast proved to be effective gear for rays and skates.

ACKNOWLEDGEMENT

We wish to place on record our sincere thanks to Dr. P. S. B. R. James, Director C. M. F. R. I., for all the facilities and help given during the course of this investigation and also our thanks are due to Shri C. Mukundan, Head, Demersal fisheries for valuable suggestions. The first author gratefully acknowledges the help and guidance from Dr. R. Natarajan, Professor, CAS in Marine Biology, Portonovo.

REFERENCES

- CMFRI, 1982 Trends in marine fish production in India-1981. *Mar. Fish. Infor. serv. T. and E. SER* No. 41: pp. 32.
- CMFRI, 1983 Trends in marine fish production in India-1982 - 83. *Mar. Fish. Infor. Serv. T. and E. Ser.* No. 52: pp. 20
- CMFRI, 1986 Marine Fish Production in India during 1983-84 and 1984-85. *Mar. Fish Infor. Serv. T. and E. Serv. No.* 67: pp. 79.
- DEVADOSS, P. 1977 Studies on the elasmobranchs of Porto Novo coast *Ph. D. thesis, Annamalai Univ. Chidambaram.*
- DEVADOSS, P. 1978a A preliminary study on the Bateid fishery of Cuddalore coast with a note on the biology. *Indian J. Fish.*, 25: 180-187
- DEVADOSS, P. 1973b on the food of rays, *Dasyatis uarnak*, *D. alcockii* and *D. sephen*. *Indian J. Fish.* 25: 9-13.
- DEVADOSS, P. 1979 Observations in the maturity, breeding and development of *Scoliodon laticaudus* M. and H. off Calicut coast. *J. Mar. Biol. Ass. India.*, 21: 103-110
- DEVADOSS, P. 1984 Further observations on the biology of the sting rays, *Dasyatis imbricatus* (Schn.) at Portonovo. *Mat-sya*, 9 and 10: 129-134.

- DEVADOSS, P. 1984 On the incidental fishery of skates and rays off Calicut. *Indian J. Fish* 31 (2): 285-292.
- JAMES, P.S.B.R. 1973 Sharks, Rays and skates as a potential fishery resource of the east coast of India. *Proc. Symp. Living resour. seas around India*. Special publication CMFRI, Cochin. 483-494.
- RICKER, W. E. 1975 Computation and interpretation of biological statistics of fish populations, *Bull. Res Bd. Can.*, 119; pp. 382.
- SARANGDHAR, P. N. 1944 Tiger shark, *Galeocerdo tigrinus* M and H. Feeding and breeding habits. *J. Bombay nat. Hist. Soc.* 44; 102-110.
- SETNA, S. B. AND P. N. SARANGDHAR 1949. The breeding habits of Bombay elasmobranchs. *Rec. ind. Mus.*, 47: 107-124
- TESHIMA, K. AND K. MIZUE 1972 Studies on sharks. I. Reproduction in the female sumitsuki shark, *Carcharhinus dussumieri*. *Marine Biology*, 14 (3) : 222-31
- WALLACE, J. H. 1967 The Batoin fishes of the east coast of southern Africa Part II: Manta, Eagle ray and sting rays. *Invest. Rep. Oceanog Res. Inst. South Africa*: 1-55.

SCHOOLING BEHAVIOUR OF TUNAS IN LAKSHADWEEP WATERS

Livingston

Central Marine Fisheries Research Institute, Mandapam
Regional Centre, Mandapam Camp

ABSTRACT

The paper describes nine kinds of schooling patterns of the Skipjack tuna (*Katsuwonus pelamis*) and the yellowfin tuna (*Thunnus albacares*) in the Pole and line (live bait) fishing grounds, as identified by the fishermen of Lakshadweep, particularly of Minicoy. These are described here as schooling patterns I to IX after giving their local names and some clue to their identification from fishing boats. The surface or subsurface nature of occurrence of the school, its leaping, feeding and swimming activity, baiting habit, vulnerability to the gear, size of the school, approximate size and species composition of the school, and the association of the school with water discoloration, floats, sea-birds, predators etc are described. The paper also describes four different approaches of the tuna pole and line (live bait) boat to the different kinds of tuna schools.

INTRODUCTION

Scientific investigations on the schooling pattern of tunas would enhance catchability of different types of tuna schools. In Lakshadweep (Latitude 8°N and 13°N and Longitude 71°E and 73°E), the Skipjack tuna, *Katsuwonus*

pelamis and the yellowfin tuna, *Thunnus albacares* form about 90% and 6% of the catch taken by the tuna pole and line (TPL) with live bait which forms the principal gear operated. Others like the little tunny (*Euthynnus affinis*), frigate tuna (*Auxis thazard*), dogtooth tuna (*Gymnosards unicolor*), black shark (*Eulamia*

melanoptera), rainbow runner (*Elagates bipinnulatus*) and the dolphin fish (*Coryphaena hippurus*) form the rest of the TPL catch. Silas and Pillai (1982) observe the existence of two kinds of tuna schools, viz., the 'breezing' and 'boiling' schools from the experimental purse seining grounds in the Laccadive sea. Madan Mohan (1985) observes the existence, ecology, catch pattern and behaviour of tuna schools associated with flotsam in the Minicoy waters, based on his observations on the landings of tuna during the 1982-83 season.

In the Japanese waters, Van Campen (1952) describes 15 different kinds of schools of tuna based on earlier works. Eighteen types of tuna schools have been recognised by the Californian tuna fleet (Scott 1969). A comparative work of the above kinds to serve as a basis for further investigations on the schooling behaviour of tunas in Lakshadweep and a practical guide to local TPL (live bait) fishermen is lacking in literature. Therefore, the various kinds of tuna schools commonly being recognized by the local fisherman experts in Lakshadweep, are described for the first time, with special reference to the Skipjack and yellowfin tunas of Minicoy TPL (live bait) fishery. Four different kinds of approach of the TPL (live bait) boat to the identified tuna schools also are described in this paper. The present work is based on enquiry with local fishermen experts and on practical observations from commercial TPL (live bait) boats. Details of study area, material and method and description of the TPL (live bait) boat, the gear and its technique of operation are given already in Livingston (MS).

SCHOOLING PATTERNS OF TUNA

A tuna school is locally called *mas aulin* in the local *Mahal* dialect in Minicoy and *Choore kottam* in Malayalam in the other islands. As soon as it is detected, its schooling pattern is identified by the chief fisherman before he gives necessary instructions to the rest of the crew onboard regarding appropriate action to be taken to catch the school. Nine major patterns of schooling of tuna are locally identified, based mainly on their behaviour

like swimming activity, feeding frenzy, biting of hooks, leaping and association with sea-birds and live bait packs naturally occurring in the sea. These schooling patterns are described below briefly, giving the local name in *Mahal* in Parentheses.

Pattern I (Madu):- This kind of school consists of a dense surface pack of tuna of almost equal size. Fish are orderly arranged in several layers of vertical thickness. Two to three vertical layers of tuna are clearly visible under water to naked eye observation from the boat. This school moves very close to surface and hence its local name, *madu*. Individual fish of the upper most layer produces a characteristic track of tiny uniform waves, each about 5 to 7 cm high, at sea surface by the flipping action of the first dorsal fin. The characteristic whitish streak present in the erect first dorsal fin of *Katsuwonus pelamis*, becomes clearly visible when the fin is in its flipping action at the air-water interphase. The waves formed by the innumerable individuals of the school at the sea surface, give the sea along the track of the school, a characteristic rippling appearance and a black discolouration detectable from about 0.5 to 1 km distance.

The pattern described above may be considered as the typical one. Due to the diagnostic behaviour of the school in exposing the first dorsal fin, this kind of school is locally distinguished from other variations of this kind as *Kothari kolla*. In a second variation of this pattern locally distinguished as *rhy kolla*, the individual tuna shows a characteristic pinkish tint superimposed especially upon the steel-blue dorsal regions of the body. A third variation is locally distinguished as *huthu kolla*, in which individual tunas in the school, intermittently and gently turn their left and right sides of abdomen upwards, and downwards in a rhythmic manner while swimming forward gently. No live bait pack or dense bird flock is found associated with this flipping school. Stray number of sea-birds may be found flying over the school at a level of about 2 to 3 m, high from sea surface, on certain occasions. Typically it is a slowmoving school of tuna with

moderate to good appetite for supplied live bait and with good fisheries prospects. The second variation of this kind mentioned above, shows the best response to chumming and gives the best catches. It is found near or away from island. Eventhough it occurs throughout the tuna season from middle of August to middle of May, it is more frequently encountered during the beginning quarter of the tuna season, when the sea is less clam, cold and turbid. Proper access to the school by the boat and chumming with live baits are obligatory for catching this school. At times, schools take an enormous size, capable of supporting the entire daily catch of even five to ten boats at a time. from the same area.

Pattern II (*Uma Kolla*):- This may be considered as the rippling school. It is a surface pattern in which the top most layer of tuna swims at about 0.5 m below sea surface. To closer naked eye observation, the rippling school appears as a compact pack of equal sized tunas of several vertical layers thickness. The track of this school is characterised by gentle rippling of the sea surface produced by the school which often superficially resembles the rippling caused by gentle breeze on sea surface. From a distance, the sea surface over the track of the school appears as a clam area when compared to the surroundings. This makes it easier to detect and identify the track of this school, especially when the sea is a little choppy. Leapings of individual tuna in the school is rarely met with. It is a slow-moving school, major part of which remains at subsurface depths invisible to naked eye. Tunas rise to surface only when chumming with live bait starts. Therefore, chumming with live bait is a must to catch this school. No natural live-bait pack or dense sea-bird flock is found associated with this school which is moving constantly towards any one direction in good appetite. It is frequently encountered near the Island. It ensures a good fisheries prospects especially during the postmonsoon months.

Pattern III (*Bandedhu furung*). The sea surface along the track of the school gives a sandy whitish discolouration detectable as a patch of whitish area from a distance of about 0.5 km.

It is a slow-moving sub-surface school, often occurring below visible depth levels. However, the school as a whole, appears as a submerged whitish object. As the school rises upto visible levels under water, individual fish are found to swim with their ventral side turned upwards and hence its local name. The school is a unispecific segregation of oceanic skipjack; the individual fish are uniformly large in size, in advanced stage of maturity, and in good condition (fatty appearance). No natural live-bait pack or sea-bird flock is found associated with this tuna school. This tuna school shows relatively poor appetite and hence poor response to chumming with live-bait. The fishery prospects are less predictable. Sometimes, some individual fish at any one part of the school come to their erect and normal swimming posture when live bait is supplied and this results in a good tuna fishery. At other times, the school does not come to normal swimming posture and it does not rise to surface to bite the hooks even after it is chummed with lavish quantities of live bait, or disturbed with trolling lines with baited or lured hooks. Commonly found in the more oceanic realm, this schooling pattern is frequent in occurrence towards the end of the tuna season from April onwards when the surface water becomes warmer.

Pattern IV (*Emmus hummelafi*). This schooling pattern is characterised by very sparse and highly infrequent or stray number of leaping of tunas in ones and twos and hence its local name. The skipjack tuna and the bigeye tuna, living at invisible depths, leaps at surface once in half an hour to one or two hours interval, from widely scattered points in the sea surface. The approximate size or direction of movement of the school is not detectable with any amount of accuracy. Sea-birds proper are absent in the tuna grounds, except isolated individuals of the relatively near-shore sea-bird, *Sterna bengalensis* straying solitarily in the vicinities. Tuna schools, are found mostly in the near-slope waters around the Island where predators like the wahoo and sail fish abound. Tunas rising to surface do not stay long at surface to support a good fishery due to fear of the above mentioned predators. Such a frightened tuna school is the only one commonly available for fishing during middle of August to middle of October, in which season the near-shore tuna

waters remaining turbid and cold are usually exploited. Response to the chum though good, biting of hook being rather poor, the trolling line is also used to take a mixed fishery consisting of a few tunas and their predatory games.

Pattern V (Hummelafi). When compared to the previous case of subsurface school, in this schooling pattern, leaping of individual tuna in gangs of a few numbers can be sighted, more frequently, here and there in the vast fishing ground which in this case is situated relatively more seaward. Oceanic species of sea-birds like *Anous stolidus*, *Sterna anaethetus* and *S. hirundo* are found in patchy hovering flight, somewhat above sea surface and they aggregate at random into small flocks diving to points of sea surface where the leaping of tuna abound. Yellowfin tuna as well as Big eye tuna of 8 to 10 kg individual weight which are too heavy for the pole and line gear to lift, abounds in the school. Occasionally, enormously large schools of these species with fish of 30 to 60kg individual weight, show leaping amuck and at random over a vast area of sea surface studding it with innumerable whitish splashes. Biting of the chum and biting of hooks, in general are poor; however a moderate fishery may be obtained on certain days from waters nearer the insular slope during dusk hours in which biting of the chum and biting of hooks are better. Several boats return to port with nil or very poor catches. This is the most commonly found schooling pattern during spells of moderate and poor tuna catch, intervening spells of good catch, within the fair tuna season from middle of August to middle of May.

Pattern VI (Adige or Adi bodu) This pattern of schooling is found at subsurface depths around 2m from where individual skipjack tuna of about 40-50 cm total length appears to naked eye observation from onboard, as tiny tots of moving objects just 10 to 15 cm long. Flocks of sea-birds in soaring flight at higher levels in the sky are found associated with this kind of tuna school. The bird flock dives to sea surface whenever the tuna school rises to surface in search of prey. Only when the tuna boat plies over the track of the tuna school, fish of the main school moving at subsurface depths become visible to naked eye. Leaping

of only stray number of tunas is found. No natural live-bait pack is found at the sea surface. It is a slow moving school tending to rise to nearer surface when chumming starts. A good fishery is possible only for about 10 to 15 minutes on any single school of this pattern, the appetite and feeding frenzy of tuna and the biting rate reducing afterwards. Therefore, a good fishery prospect is only a matter of chance. This kind of school also occurs throughout the tuna season at different spells with poor to moderate tuna catch.

In a variation of this schooling pattern which is locally distinguished as *dhuuva mas auin*, the tuna school at the subsurface depth level of about 1 m, are found progressing at high speed. The school is often quite extensive. No fish leaps over water. Only by a lavish supply of live bait in chumming operations, this tuna school can be made to follow the tuna boat, in a sustained manner. Good fishery prospects are uncertain. This pattern of schooling is met with from March onwards, during spells of uncertain tuna catch in which the local seasonal drifts become weak.

Pattern VII (Badithala). It is a pattering school in feeding activity. Tunas in innumerable numbers are distributed rather in a loose manner over a vast area of the sea in which are distributed ball-like aggregations of natural live-baits packs, here and there to get scattered as prey for tuna. Tuna swim between neighbouring live-bait packs in haste to form small aggregations. Scores of leaping of individual tunas and the resultant whitish water splashes, can be found within a short while, from any direction in the schooling area. Sea-birds are also found hovering in more abundance here than in any other pattern of schooling and they are actively diving frequently at closer points while flying from one to another live-bait pack, Birds produce a characteristic chirping noise and they do not rise above a height of a few meters from the sea surface. A noise similar to that of falling rain drops, is characteristic in the area. There being plenty of natural prey at the sea surface itself, response of tuna to chumming with live bait from onboard is rather poor. The biting of hooks and fishery prospects are moderate. This schooling pattern is observed especially in the beginning of the tuna season

proper, i.e. around mid-November, when the sea becomes very calm, warm and clear and enormous quantities of drifting natural live-bait packs become available in the oceanic tuna grounds.

The only interesting variation of this pattern is described below. The feeding activity is maximum around each naturally occurring live-bait pack when the aggregation of tuna around the pack becomes large. The black shark, (with its mouth wide open for prey in certain schools) is commonly found circumventing the live-bait pack, along with the skipjack tuna and the yellowfin tuna which bounce upon the scattered live baits very vigorously. Other predatory species such as the rainbow runner, little tunny, frigate tuna and dolphin-fish, are also present in the feeding assemblage. Tuna of small and medium size groups mix in this feeding ground. The predators, in general do not dare to swim over the individual live-bait pack; but they swim around it, waiting for a chance to feed upon any few small fish which may get scattered away from the main pack. The sea birds with a characteristic chirp, dive vigorously and very frequently around the live-bait pack, forming cluster-like densest feeding aggregation around each individual pack. Bird-flocks in the air overcast the area considerably. No chumming proper with live bait is required to catch tuna of this schooling pattern. The school is very slow moving as the live-bait packs are to be carried away only by the water drift which is often slow during this season. Tuna exhibit good appetite and take hooks vigorously giving a good fishery only if there is no disturbance from larger predators which may abound in more number around some live-bait packs. This actively feeding and slow moving tuna school of relatively large aggregations is distinguished from the typical hastily main school of confused small aggregations scattered over a large area as *happa mass auin* by local fishermen.

Sailfish and marlin are the common predators which are chasing tunas of this actively feeding school. The speedier plight of the tuna school is a sure indication of these predators chasing the tuna school. Tunas often come very closer to the stern and quarters of

the boat to hide and these predators furiously dash their beak against the hull of the boat at times. Occasionally, tunas approaching the rudder blades get cut into pieces and float at the wake of the boat. Stray leaping of individual tuna to heights of a few meters in air is found when the tuna school gets frightened by the above mentioned predators. The shadow of the leaping fish is followed underwater by the predator which catch the prey. Individual tuna being pierced, lifted up and tossed in air at the tip of the beak by the sail fish also is found at times. Tuna when scared by the predator swim hastily to escape. Biting of hooks becomes poor due to the urge for escape from the predator. Such a scared tuna school takes a zig-zag route, swimming speedily, making it difficult for the boat to follow the school. The tuna school associated with the black shark in feeding on the natural live-bait pack are calm with no fear for the shark and with no fright in fishing them.

Dead specimens of large yellowfin tuna in stray numbers, have been taken in fresh or semi-spilt condition from the natural live bait packs in the sea by local fishermen at Minicoy. Such natural mortalities seem to be due to accidental swimming over of the predator on the compactly arranged live-bait pack which is often several scores of fish thick vertically.

Pattern VIII (Ethikandu). This is a tuna school associated with flotsam. In this pattern of schooling, generally, tunas of small size (0.5 to 1.0 kg) are found to form large aggregations around floating objects, such as logs and timber and a variety of other salvages like coconut-and other Palm leaves, pieces of rubber, plastic, synthetic nets etc. The submerged surface of the floating object, is found with colonies of *Lepas*. Polychate worms are also found in crevices of the timber. An assemblage of small fishes such as the young ones of rainbow runner, dolphin fish, the dotted leather jacket etc. are found associated with the floating object. These in turn are surrounded by a dense aggregation of different species of tunas and the black shark which appear to feed on these small fishes when the prey get scattered from the main aggregation. The entire assemblage is moving slowly along the

drift together with the floating object. According to the position of the Sun, the entire assemblage of fishes including tunas, orients itself and concentrates towards the leeward side of the floating object where its shadow falls. Tunas of the assemblage become sparsely distributed and spread loosely around the floating object when the individual fish move away for feeding. But whenever any disturbance or fear from enemies comes the entire assemblage once again becomes densely aggregated below the floating object. Tuna being found along the peripheral zone of the assemblage, individual fish appear rather lean and poor in condition, as if they are underfed due to over crowding. Among tunas, the Skipjack tuna and the yellowfin tuna predominate in the assemblage with little quantities of the other tunas. The skipjack tuna abound in some parts of the assemblage while the yellowfin tuna predominates in some other part of the same assemblage of fish, associated with the flotsam.

Sea-birds only in stray numbers may be found perching or hovering over the floating object. When present, Sea-birds are found to take a slow hovering flight from side to side within a limited area and they may dive to sea-surface periodically. They are found at a very lower level closer to sea surface. Chumming with live-bait is often not necessary. A few leaping of tuna with whitish splashes of water may be present. The fishery prospects, in general are very promising; often each tuna school is so large and rich that it supports the catches of two to three boats full of tuna simultaneously. Unlike from any other schooling pattern, considerable numbers of the species of fish other than the oceanic skipjack and the yellowfin tuna, also are caught. Tunas are locally reported to form much large aggregations around the coast-going sailing crafts also. Such dense accumulations of tunas below the vessel is considered to be helpful in the navigation of the vessel by the contribution of the dense school in increasing the calmness of the waters around the vessel in plight.

A variation of this typical schooling pattern is distinguished locally as *oi valung*. In this the floating object is missing as a primary or secondary condition; fishermen themselves

remove the floating objects such as logs of timber and coconut leaves etc towards the end of the day's fishing. Timber obtained from this source is removed for industrial purpose also. The remainder school of tuna now devoid of any floating object to depend on, readily moves along the current boundaries where the flotsam existed. This school follows the boat itself, once the boat plies into the area. A handsome tuna fishery is expected from such a school of tuna which is easily identifiable in frontal zone locally called *oi dhandi*. Presence of salvaged floating objects if any, behaviour of stray sea-birds and leaping tuna in the same manner as described above, help in detecting this school of tuna. Tuna taken from the school associated to flotsam are always lean in appearance, small in size and are eager to feed with almost empty stomachs. Therefore, experienced local fishermen are capable of detecting the presence of this school of tuna, even from a single fish taken by the trolling line which is used as a test line in places where the floating object is not visible primarily or it is removed by other fishermen already. This kind of tuna school is caught intermittently throughout the fair tuna season.

Patter IX (Bodu-mas mas auin). This kind of school is associated with the black whale and hence its local name. The skipjack tuna is the species reported locally to follow the whale which appears to the observer as a black rock in the sea surface. This kind of school is not caught. As soon as the whale is sighted at a distance, the boat changes its course to avoid the whale-associated tuna school owing to fear of the local fishermen for the whale which according to them may cause the boat to capsize. This kind of tuna school is met with in the summer months off the west coast of Minicoy.

APPROACHING A TUNA SCHOOL BY THE BOAT

Correct approach of the boat to a tuna school is a must in successful TPL (live bait) fishing. Once a tuna school is scouted and the schooling pattern identified, the correct

course of the boat in relation to the tuna school is achieved by correct approach tactics of maneuvering the boat. A wrong approach of the boat to any tuna school results in the abrupt disappearance or rapid scaring away of the tuna school. For a correct access with regard to a tuna school of any of the above described schooling patterns, the chief fisherman at the steers fixes the leading or head end of the tuna school as his main target of observation throughout the period of fishing from that school. The direction and speed of plight of the boat are adjusted according to the speed and direction of movement of the head of the school only. For scouting the leading end of the school initially and then pursuing it up continuously, one or more of the surface observations such as (1) the direct visual scouting on moving individual tunas at the head of the school, (2) leaping and splashing of tunas ahead of the boat, (3) speed and direction of general flight and diving position of sea-birds, come to the aid of the chief fisherman.

Courses of approach. The general course of approach of the tuna boat to a particular identified tuna school may be described conveniently under the four kinds, *viz.*, (a) Lateral approach (b) Central approach (c) Peripheral approach and (d) criss-cross approach.

(a) *Lateral approach:* This is a straight line approach of the tuna boat to a tuna school along the side of the school. This method of approach is generally applicable to a tuna school which may pick up excessively high speed at any moment. Fast moving school under schooling patterns I to VI are often approached by this method. Here, the tuna school often being in relatively moderate or less appetite, abrupt entry of the boat over the school, often results in either the abrupt sinking and disappearance of the school or in its picking up of so enormous a speed that the boat with even all its capacity is not able to cope up with; the school taking an undesirable swimming position always in front of the boat and not abaft it (which latter condition is a must for chumming the school to the Pole and line gear).

The approach along side may be effected in five different ways as shown in Fig. 1 (a) to

(e), depending upon the initial direction of the course of the boat when the tuna school is just encountered. However, the method as shown in Fig (a) is mostly preferred to other methods because it gives more chumming feasibility with regard to the port side quarters of the fishing platform where are found the most able crew from among those who operate the pole and line gear (leading fishermen).

Whenever, two or more boats aim at approaching the same tuna school so as to get their fishing access into the same school, as a general convention, the priority in the time of approach is considered as a matter of right of each boat to go nearer the school. The first boat approaches the tuna school by adopting any one of the five courses shown in Fig (a) to (e), and each subsequent boat according to its order of priority takes its rear positions alternately either to the right or left of its predecessor boat which is fishing just in front (Fig. e). None of the subsequent boats is supposed to overtake its predecessor boat while fishing from the same tuna school. Any serious violence of this conventional practice is a punishable crime amongst the local fishermen brotherhood. This practice comes from the fact that whenever a boat is overtaken hurriedly by another boat, due to the disturbance in water caused by the latter boat, the school being chummed by the former boat gets distracted or disappears altogether.

(b) *Central approach:-* This is a straight line approach of the tuna boat to a particular tuna school, in which the boat plies over the centre of the school, as shown in Fig. (f). This method is used to get an uncertain access into a slow moving surface or subsurface tuna school which exhibits poor appetite under schooling patterns III-VII. Initially (especially when no tuna has been caught for the day), special care is taken to see that the boat does not overtake the school lest it disappears abruptly. However, in a situation in which tuna do not take the chum even after repeated chumming with live-bait, the boat plies over the school with minimum care about the sinking of the school, yet with some hope of improvement in the appetite and chumming response of tuna. In the typical schooling pattern VII, in which numerous confused schools of small sized

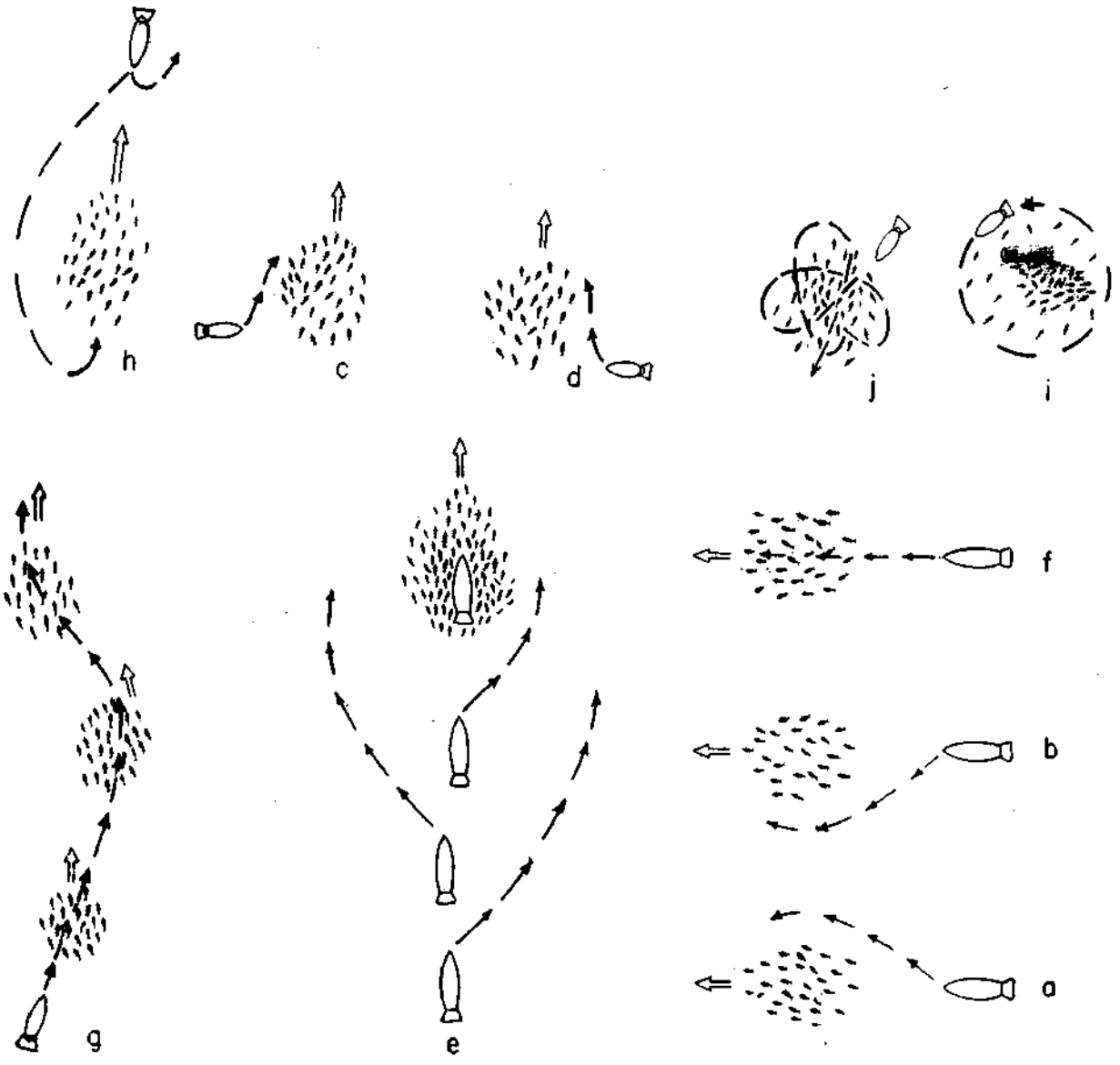

Fig. 1

aggregations of tunas occur over a large area of the fishing ground, the boat plies over individual tuna schools in a straight line, one after another (Fig. g).

In an encountering situation as depicted in Fig. h in which the tuna school and the boat are moving in opposite directions, extreme care is taken to keep a safe distance between the boat and the school, until the boat begins to approach the school from behind as indicated by the long and thin arrow in the figure. The

short and thin arrow in the same figure shows another alternative and safe method of approach in the same kind of encountering situation of the school; here the direction of plight of the boat is turned to about 180° as soon as the school moving in the opposite direction is sighted at the farthest distance which permits the identification of the school. This turning of the boat should be made before the school is disturbed by the wake or by the physical presence (shade) of the boat, lest the school disappears.

(c) *Peripheral Approach*:- It is a circular line approach of the tuna boat to an identified tuna school, by the boat plying repeatedly around the periphery of the school (fig 1). This method is applicable to schooling pattern VIII and to varieties of actively feeding larger aggregations under schooling pattern I (*hudhu kolla*). The orientation of the school to sunlight is taken into account in this method of approach, especially if the object is fairly large in size. As better concentration of the fish is found at the shady side of the floating object, the boat plies around the object in such a way that the object is maintained more towards the sunward periphery of the circle of plight. The fish associated with the floating object are swimming rather loosely in search of food, in the vicinities of the floating object and they form dense accumulation around the floating object as soon as the boat comes nearer. Therefore, initially the boat makes a wider circle around the entire loose aggregation of fish associated with the floating object and then gradually reduces the radius of the circle of plight as the fish forms a thick aggregation around the floating object. The floating object is seldom disturbed or removed until the boat is loaded to capacity with tuna caught from the school. Whenever, two more boats are fishing from the same school, it is always the first boat that plies along the inner circle and no subsequent boat is supposed to come still closer to the school without the permission from of the chief fisherman of the first boat; such a permission being given often only when the first boat is packed to capacity with tunas taken from the school.

(d) *Criss-cross Approach*:- In this method of approach, the boat plies over the identified tuna school repeatedly along a semicircular path placed one over the other in a rather criss-cross manner (Fig. j). It is used to slow moving varieties of tuna school of good appetite under schooling patterns I (*rhy Kolla*) and VIII (*happa mas eulin*). Here, the feeding frenzy of the tuna school is aggravated by scattering the school which is otherwise compact. The live bait packs (around which tunas accumulate for feeding), also are shattered and the live baits in the pack are scattered into fractions

of a few individuals by the repeated criss-cross plight of the boat over the schools of tunas and live baits.

DISCUSSION

The present investigation reveals for the first time that there are 14 different kinds of tuna schools coming under nine major schooling patterns in the Minicoy waters. Out of these only four kinds of schooling patterns viz., Pattern I, II, VII and VIII are commonly reported locally from the remaining nine inhabited islands (Chetlat, Bitra, Agatti, Kiltan, Kadmat, Ameni, Kavaratti, Androt and Kalpeni) in Lakshadweep. The first three of these schooling patterns in order, are locally distinguished as *Kunuth pondathe*, *Umikindathe* and *Pathakindathe* in these Islands. The 'breezing' and 'boiling' school of tuna observed by Silas in Silas and Pillai (1982) from the Laccadive sea appear to be the same as patterns II and VII of the present description.

A comparison of the present 14 kinds of tuna schools of Lakshadweep, with different kinds of tuna schools reported by Uda (1933), Van Campen (1952) (ominaga (1957) and Tomyama and Hibiya (1976) from the Japanese waters and Scott (1969) from the Californian waters indicates the following interesting facts. The skipjack tuna schools associated with bait-bed, sharks and drifting wood and the unassociated school, met with in the Japanese waters appear to be similar to schooling patterns VII (*badi* and *Happa*), VIII (*Ethi-kandu* and *oi-valung*), in order, described here in Lakshadweep. Further, the 'Silver flow', 'Calm ones' 'Sednetary fish', 'Jumbers' and 'Sleepers' of Japanese waters resemble Patterns I (*Hudhu*), III, IV, VI and VII (*Happa*) respectively of the present observation. The *Namura* and bottom-*Namura* of Japan represent the surface and sub-surface tuna in general in Lakshadweep, irrespective of the schooling pattern. The surface school types viz. Breezer, Finner, Jumber, Boiler of foamer, Smoker and Log-school of the Eastern Pacific resemble Patterns II *Uma kolla*, I (*Kothari*), IV (*Emmus Hummelafi*) V (*Hummelafi*), VII (*badi*) and VIII (*Happa*) of Minicoy waters. Thus, there is a fundamental similarity in surface schooling patterns of the Skipjack and

the yellowfin tunas in Lakshadweep, Japanese and Californian waters. However, more precise and standard Scientific terminology to denote tuna schools on an universal basis is required in this connection.

However, pattern III with Skipjack tuna of fairly large individual size swimming upside down, resembles very much both the 'shiner' and the 'whitebellies' in the Californian waters. This needs further confirmation. This pattern has also similarity with the 'Resting skipjack' of Japanese waters in which the fish refuse to take the chum (live-bait) as at Minicoy. The migrating type of tuna schools resembling the northbound 'ascending Skipjack', the southward returning 'descending Skipjack', the open sea school of 'Rowing Skipjack' and the 'adventitious fish' proper etc., reported from the Japanese waters are yet to be reported, if available, in Lakshadweep. The luminescent night schools reported by Purse seiners in Californian waters also are to be searched for in Lakshadweep. Further, in the eastern Pacific, Skipjack and Yellowfin tunas are reported to be associated with mammals like the Pacific spotted dolphin (*Stenella graffmani*), Spinner Porpoise, *S. longirostris* and the common dolphin *Delphinus delphis*. In Minicoy waters, however, *D. delphis* could be observed on several occasions in stray numbers, upto six at a time near the boat; but no surface tuna school was found associated with this mammal. The tuna school in this case may be a sub-surface association which needs further investigations to develop tuna purse-seining for such schools. *Cetorhinus* sp and *Rhinoodon* sp are the two common sharks reported to be associated with tuna Schools in the Eastern Pacific. But in Lakshadweep, *Eulamia melanoptera* is the only common species of shark found associated with tuna schools.

As quoted by Nakamura (1969) from Tominaga (1957) it is clear that in the Japanese waters the skipjack tuna which bite well maintain an orderly formation, an unvarying speed and a uniform direction; they create small, uniformly spaced ripples on the surface of the sea, and expose no more than the tip of their dorsal fins; one or two fish at the head of the school may jump out of the water; the

fish are not frightened by an approaching vessel. This is found to be true with schooling Pattern I (*Kothari*) of Lakshadweep. Further, according to the above work, poorly biting schools are: those with a disorderly formation direction of advance is not fixed, the school tends to break into smaller schools, and waves on the surface are large and unevenly spaced; fish leap near the middle or at the rear of the school; and fish sound and reappear repeatedly when approached by a vessel. This also is generally true with the behaviour of the Skipjack tuna in Lakshadweep, however, more accurate observations are required in this connection. Air spotting of tuna in the New Zealand waters revealed the breezers and the flashers or shiners of foaming or boiling school of the Skipjack tuna (York, 1977). These resemble schooling Patterns II and III of the Lakshadweep waters.

The exact causes for the formation of the different kinds of schools formed by the Skipjack tuna and the co-occurring young yellowfin tuna in Lakshadweep are not known. After examining the various hypotheses explaining the causes for the association of tunas with the floating objects, Madan Mohan (1985) concludes that this association is nothing but merely a coincidence and that the floating objects appear to serve only as companions drifting at the same direction with the tuna school. However, the present onboard observation indicates that the association of the medium-sized individuals of the Skipjack tuna with the drifting floating dead-objects, wooden sailing vessels, whales and sharks etc., is an ecological adaptation for a pelagic mode of life at the surface of the Sea where the waters are relatively of high transparency for a visual mode of feeding. Observations from an underwater viewing chamber on tuna behaviour made in the Hawaiian waters reveals that when compared to large individuals (70-80 cm), medium-sized (45-65 cm) Skipjack tuna show more frenzied activity, better formation of feeding schools, and very active pursuit of the prey with rapid surface dashes (Stranbury and Yuen 1959). Van Campen (1952) reveals that the Skipjack tuna in the Japanese waters do not have very good vision obliquely to the rear. Experimental feeding

under captivity in Hawaii shows that the Skipjack tuna do not feed down the bottom, they always accept feed from the surface (Nakamura 1962). The Minicoy fishermen report that large sized individuals of Skipjack tuna lose their eye sight during certain spells of the year and they can not feed at such times. All these prove that medium-sized Skipjack tuna prefers the surface layers to the sub-surface of the euphotic zone for its visual feeding. The drifting dead object serves as a visual mark of identity for tuna to determine their feeding range around the object. These drifting objects being accumulated along frontal zones of abundant tuna forage, tunas are taken to better feeding grounds. The importance of temperature, transparency and forage as conditions congenial for the normal distribution and commercial concentration of tuna is dealt with in Blackburn (1964).

Only maturing Skipjack tuna (stages II and III) are found associated with the drifting objects at Minicoy. It is at these stages in life history, the feeding activity is more vigorous. This also indicates that the tuna aggregate around the drifting object mainly for feeding purposes. When the fish grow to maturity stage IV and above, they give up the floating object and descend down to form sub-surface schooling patterns (III, IV, V and VI) and come to surface only erratically. Large individuals also form surface schools as under schooling patterns I, II and VI. The abundant availability of forage organisms at the surface appears to be the main cause for the formation of these patterns also.

The co-occurrence of the young yellowfin tuna with the skipjack tuna also appears to be an adaptation for the pelagic mode of life. The whitish streak present in the erected first dorsal fin of the Skipjack tuna appears to attract the other individuals of the same species and of the young yellowfin tuna. Owing to difference in swimming speed, small and large individuals cannot cope-up with medium-sized tuna while swimming, aiming at the distinct first dorsal-white streak of the leading fish in front in the school. This may be the cause for the formation of schools consisting of similar sized fish. Brock (1954)

observes that swimming speed is perhaps the cause for the size-wise segregation of tuna even in mixed schools. Joseph and Barratt (1963) observes that the Skipjack tuna is of an erratic and excited behaviour and that it becomes clam when it co-occurs with the yellowfin tuna which is of a mere subdued behaviour. Skipjack tuna becomes more vulnerable to purse seines when these two species co-occur in mixed schools. This appears to be true with regard to the vulnerability of these two species to the TPL (live bait) gear at Minicoy also.

With regard to vulnerability of the different kinds of the tuna school to the Skipjack TPL (live bait) gear, it is clear that the surface schools in general (Patterns I, II, VII, VIII and IX) show a relatively good fishery prospects. The vulnerability of the surface school associated with whale (Pattern XI) could not be observed because this school is not being fished at present. Biting of the hook and of the chum, in general is relatively good with regard to schooling patterns in the surface (Patterns I, II, VII and VIII). These schools show relatively good appetite and feeding frequency in comparison to those of the sub-surface layers (Patterns, III, IV and V). There is considerable economy in live-bait with regard to surface schooling patterns. Considerable part of the Japanese catch is reported to come from Log-Schools resembling pattern VIII.

Therefore, it is advisable to use alternative type of fishing gear such as the Tuna Purse seine, Tuna long line and TPL (live bait) with the two-poles, three-poles etc team gear to catch the sub-surface schooling patterns (III, IV, V and VI) in these waters where at present these schools are being exploited only at a very nominal level. Tuna purse seine provided with special safety measures for the release of whales, may be used for catching surface pattern IX, associated with whales which now remains virtually untapped. The schools of the yellowfin tuna and the big-tuna of individual fish weighing 8-10 kg, coming under schooling pattern V are at present a menace to the Skipjack TPL (live bait) gear, because of large scale breaking and loss of poles, as it is commonly found at spells of occurrence

of these heavier tuna which are too heavy to be lifted by the presently used bamboo Poles. Only a very negligible fringe of this particular resource is being exploited at present by means of the trollingline (auxiliary fishing) gear operated from TPL (live bait) boats in these Islands.

The school of large yellowfin and Big eye tunas with individual fish weighing 30-60kg (Vide Pattern V), represent the best part of our exploitable tuna resources which at present is undergoing the most colossal waste owing to regrettable underfishing. Eventhough enormously extensive surface schools of such monstrous fish are detectable at certain spells from the surface leaping and surface dashing of individuals of voluminous giants at closer intervals in time and space, no exploitation is being made at present owing to lack of suitable fishing gear. However, one or two stray specimens are being taken by the hand line, trolling line or shark long line, in different Islands to attract a large crowd of spectators to have a look at these monstrous games. Catching these stocks as early as possible is a must, because these appear fairly aged and hence more vulnerable to natural mortality and these may migrate beyond our Exclusive Economic Zone to support fisheries to other nations which are liable to compete with us in tuna fishing and trade. Tuna purse seine, Trolling lines (operated with the help of special boats with booms) and TPL (live bait) with three-men, four-men etc. team gear may be used to catch these stocks from the surface. Tuna long line meant specially for yellowfin tuna and that adapted for catching the Big eye tuna can be used to exploit these resources from depths. The behaviour of these stocks imbalancing and capasizing the country crafts operating hand lines in the deep waters lying between Ameni and Kadmat is locally reported.

It is interesting to note in this connection, that high hooking rate leading to commercial feasibility of longlining yellowfin tuna of 30.0-31.8 kg average weight is reported from off Karnataka, Lakshadweep and West of Lakshadweep and Maldives in fishing areas, 14-72, 13-73, 12-70 and 1-69, during the

September-January season. Bigeye tuna also recorded high hooking rate in the Equatorial Indian Ocean south-west of Lakshadweep and Maldives, in areas 3-77, 5-68 and 7-91 (Varghese *et al*, 1984; Joseph, 1984 and 1986; Sulochanan *et al*, 1986 and Swaminath *et al*, 1986): High Values of Yellowfin tuna hooking rates comparable to those of Japan, Taiwan and Korea is reported for the Basses de Pedro Bank areas 12-73, 13-72, 14-71 and 14-72 during the January-March Season with northerly migration of tunas from October to March and the possible acting of this Bank as a FAD with its immense availability of tuna forrage, mostly, squids and cuttle fish, also is reported recent by (Sivasubramaniam, 1985; Swaminath *et al*, 1986 and Sivaprakasam and Patil, 1987).

With regards to economic utility of tuna taken from the different schooling patterns, it is clear that the tuna caught from pattern VIII rejected by the local canning factory at Minicoy owing to the uneconomic small individual size of tuna. However, this catch is preferred to tuna taken from other kinds of schools, by the local people of Minicoy, for producing *mas-min* a local product comparable to *Katsubushi* of Japan. The soft-tissue of this tuna gives more pliability to the product which is considered superior in quality to that produced from large individuals. The yellowfin tuna in general is less preferred to Skipjack tuna for making *mas-min* owing to higher loss in weight of the former during processing and drying. But both these fetch the same price in the canning factory in fresh condition. Therefore, mixed schools of Skipjack tuna and yellowfin tuna are fished preferentially for skipjack tuna, if the catch is meant for *mas-min* making. Catches taken from the erratic sub-surface schools which delay the return trip of boats owing to the greater loss of time spent in fishing, get rejected in considerable numbers (about 30% of the catch) by the canning factory. This is because, as the time lag between retrieval and landing of the fish increases, fish which get injured due to heavy fall onboard from the gear, get gradually deteriorated before it reaches the canning factory. The rejected part of the catch thus goes for making it into *mas-min*. In this connection also, it is better to use alternative

fishing gear to catch the sub-surface schools Patterns III-v). The catches taken from the surface schools, on the other hand are obtained at a relatively short time duration and hence keeps quality. More than one trip also becomes possible at certain spells from these schools thus making fishing more lucrative; time loss in searching for schools being the minimum.

The four different methods of approach of the boat to the identified tuna schools, described in the present paper are of considerable value for commercial fishermen to remove their doubts and superstitious fear regarding the reported bad effect caused by the toot of the engine or mechanised TPL (live bait) boats on tuna schools in Lakshadweep waters. According to some fishermen at Minicoy, the tuna schools in general, approach the sailing traditional tuna boat (*mas-odi*) more readily and sustain behind this boat for a longer duration to support better tuna catch than it is in the case with the mechanised fishing boats. The bad effect of the noise produced by the engine under poor maintenance in fishing boat also is reported from elsewhere by researchers. Such studies are required for Lakshadweep. In this connection, the present observation on the correct method of approach to be followed with regard to different kinds of tuna schools is of special value, both for commercial fishermen and for researchers.

According to Ben Yami (1980) several factors such as the wind direction, sea condition, tuna school behaviour and direction of school movement, swimming speed of the prey (live bait) species, and the position of the fishing vessel are to be taken into account for approaching a tuna school correctly by the boat. The method of 'Peripheral approach' described here for schooling pattern VIII agrees with the normal method suggested by the above author for approaching the tuna school around floating objects. The present 'Lateral approach' also agrees with the above authors 'correct' method of approach illustrated in fig. 115 in Ben Yami (1980). The 'wrong' method of approach illustrated in the above figure by the above author also is found to be correct for approaching the school under certain situations as under

schooling Pattern VII (vide Central approach) described in the present work.

The traditional knowledge regarding the identification of the various schooling patterns of tuna and the correct approach of the TPL (live bait) boat to the identified individual tuna school, remains to be the valuable trade secret of only a handful of chief fishermen of the Island of Minicoy where only the Skipjack TPL (live bait) fishing technique exists since the long traditional past. These chief fishermen hail mostly from the *Thakrufan* and *Thakru* sub-castes. Majority of the common fishermen in Minicoy and in the remaining Islands do not possess this valuable traditional knowledge. Since the introduction of mechanized fishing boats in all these Islands and the extension of the skipjack TPL (live bait) fishing technique from Minicoy in the remaining Islands since 1962, there is a great demand for skilled tuna fishermen in all the Islands. Since recent years, many youths belong to the non-traditional tuna-fishermen sub-castes like *Manickfan* and *Raveri* in Minicoy and *Koya*, *Malmi* and *Melacheri* in the remaining Islands, have taken to TPL (live bait) fishing. These new generations of fishermen are ignorant of the schooling patterns of tuna and the correct approach of the boat to the school. Therefore, there is urgent need to impart proper training to the local fishermen in all these Islands, on the identification of the tuna schools and the correct methods of approach of the boat to identified tuna schools, as part of the local fishermen training programme on Skipjack TPL (live bait) fishing technique.

Some modern lines of research on the schooling behaviour of the skipjack tuna are given below. In an interesting review of field observations on tuna behaviour such as feeding, schooling, sounding in relation to the thermocline, associations with other organisms and objects, swimming speeds, attraction to surface disturbances and repulsion by sound and light with reference to Pole and line, trolling, longline, and Purse seining fisheries for tuna is made by Nakamura (1969) in Ben-Tuvia and Dickson (1969). Lines of work such as: (1) Experimental feeding of schools of the Yellowfin tuna and the Skipjack tuna with non-

traditional live-baits (say for e. g. with mackerel and Sardine), artificial lures, and chopped cabbage, as done in the Eastern Pacific (Stranburg and Yuen, 1959), Japan (Van Campen, 1952) and in New Guinea (as quoted by Nakamura, 1969); (2) Experimental studies on the effect of water sprays on the response of the skipjack tuna as done in the Hawaiian waters (Yuen, 1959); (3) measurement of swimming speeds of the Yellowfin tuna and the Skipjack tuna as done by Yuen (1959) in Hawaiian waters; (4) studies on the swimming characteristics of tuna under different depth-levels and migration in different current zones, as done in the Japanese waters and (5) sounding behaviour of tuna in relation to the thermocline as reviewed in Nakamura (1969) would be interesting. Medium and large-type Pole and line (live bait) vessels in whose bait well skipjack tuna and the yellowfin tuna can be confined for observation (Joseph and Barret, 1962) is the immediate requirement to start such studies. Additional facilities such as viewing chambers attached to or built into a research Vessel (Stranburg and Yuen, 1960), raft to survey ecological and behavioural interactions of tunas and other species of fishes which are attracted by drifting objects in the open ocean, as used in the Equatorial Pacific (Gooding, 1965), Portable fish tank used for transporting tuna from Pole and line fishing ground in the Sea to a pool on shore as used in Hawaii (Nakamura 1962), small two-man submarine (quoted in Nakamura (1969), large on-shore tanks for keeping tuna under captivity (Magnuson, (1963) etc, are to be added gradually.

Some more lines of investigations on tuna and live bait schooling behaviour required for improving the Lakshadweep tuna fisheries include: (1) Searching for bait-fish packs ('meat ball's) of pattern VIII as indicators of tuna schools feeding on them and catching this bait-fish stock using modern nets like lampara and small purse seine for utilization in TPL (live bait) fishing; (2) aerialspotting of live baits and tuna schools; (3) use of acoustic gear like the Sonar to detect Sub-surface pelagic fish schools in open Ocean fishing where reflections from the Sea bed do

not overshadow the fish echoes, and Echo sounders to pick up echoes from bait-fish schools (directly beneath the boat) on which tuna feeds; (4) detection and attraction of tuna schools from sounds made by tuna and associated animals; (5) spotting tuna and live-bait schools from onboard crow's nest raised above deck level; (6) detecting tuna schools using temperature-Recorders like Mercury thermometers and Probe thermometers (Roberts *et al.*, 1972) and (7) investigating with long lines the different depth levels in which different species of tuna form schools in fishable concentrations.

ACKNOWLEDGEMENT

The author is thankful to Dr. P. S. B. R. James, Director, Central Marine Fisheries Research Institute, Cochin-31 for all encouragement given in preparing this paper. The author's sincere thanks are also due to Dr. E. G. Silas, Former Director of the Institute and to Shri K. V. Narayana Rao, Head of Division, Pelagic Fisheries of the Institute for having given guidance during the course of the work. Lastly, but not least, the author is thankful to Dr. J. Marcelle, FAO, for making available to him a few of the important pieces of literature referred in this work.

REFERENCES

- BEN-TUVIA, A. AND DICKSON, W 1969. Proceedings of the FAO conference of fish behaviour in relation to fishing Techniques and Tactics Norway, Bergen, 19-27, October 1967.
- BEN YAMI, M 1980. Tuna Fishing with Pole and line Edited by M Ben-Yami, FAO. Published by Fishing News Books Ltd. Surrey, England.
- BLACKBURN, M 1962. Tuna Oceanography in the Eastern Tropical Pacific. *Spec. Scient. Rep. U. S. Fish Wildl. Serv. (Fish)* : (400) : 48 p.
- BROCK, V. E. 1954. Some aspects of the biology of the aku (*Katsuwonus pelamis*), in the Hawaiian Islands. *Pacific Sci.*, 8 (1) : 94-101.

- GOODING R. M. 1965. A raft for direct sub-surface observation at Sea. *Spec. Scient. Rep. U. S. Fish Wildl. Serv (Fish)* : (517) : 5 p
- JOSEPH, K. M. (1984) Salient observations on the results of Fishery Resource Survey during 1983-84. In : Important observations on Deep Sea fish resources made during 1983-84 : Fishery Survey of India, Bombay : 1-11.
- JOSEPH, K. M. 1986 Some observations on Potential fishery resources from the Indian Exclusive Economic Zone (EEZ)- *Bull Fishery Survey of India* No. 14 June 1986 : 1-20.
- JOSEPH, J AND I. BARRATT 1962. The Schooling behaviour of Pacific yellowfin and Skipjack tuna held in a bait well. *Calif. Fish. Game*. 49 (1) : 55.
- LIVINGSTON, P. (MS) Tuna Pole and Line (live bait) Fishing Technique of Lakshadweep -Some suggestions for improvement. Paper presented in the National Symposium on Research and Development in Marine Fisheries, 16-18, September, MRC of CMFRI, Mandapam Camp.
- MADAN MOHAN 1985. Observations on the Tuna shoals associated with flotsam in the offshore waters of Mincoy Island during 1982-83 season. In: The Fisheries of the Exclusive Economic Zone of India : Biology and Stock Assessment (Edtd) E. G. Silas, CMFRI, Bulletin 36pp. 188-192.
- MAGNUSON, J. J. 1963. Tuna behaviour and physiology, a review *FAO Fish Rep.*, (6) Vol. 3 : 1057-66.
- NAKAMURA, E. L. 1962. Observations on the behaviour of Skipjack tuna, *Euthynnus pelamis*, in captivity, *Copeia*. 1965 (2) : 234-5.
- NAKAMURA, E. L. 1969. A review of Field observations on Tuna behaviour. *Proc. F. A. O. Conference on Fish behaviour* in relation to Fishing Techniques and Tactics. Bergen, Norway, 19-27, October 1967, FAO (1967) pp 69-100.
- ROBERTS, P. E., D. BAKER AND E. B. SLACK 1972. Tuna in New Zealand Waters. Fisheries Research Division Occasional Publication No. 4 : 31 pp.
- SCOTT, JAMES MICHAEL 1969. Tuna Schooling Terminology. *Calif. Fish and Game* Vol. 55 (2) : 136-140.
- SIVAPRAKASAM, T. E. AND S. M. PATIL 1987. Results of Exploratory tuna long-line Survey conducted in the Arabian Sea off Southwest coast of India during 1985-86. *Occasional Papers of Fishery Survey of India*, No. 3 April, 1967:1-20
- SIVASUBRAMANIAM, K 1985. Tuna Fishery in the EEZs of India, Maldives and Sri Lanka. Bay of Bengal Programme : Marine Fishery Resources Management. BOBP/WP/31 : 1-91.
- SULOCHANAN, P., JOHAN, M. E. AND K. N. V. NAIR, 1986. Preliminary observations on tuna resources of the Arabian Sea with particular reference to distribution pattern of Yellowfin tuna, *Thunnus albacares* (Bonnaterre). *Bulletin of Fishery Survey of India*, No. 14, June 1986 : 21-33.
- SWAMINATH, M., M. K. R. NAIR AND P. PRAVIN 1986. Oceanic Tuna- A feasible fishery in Indian EEZ. CIFNET/BULL/03/MFR Marine Fishery Resources-October 1986 : 72 pp.
- SILAS, E. G. AND P. P. PILLAI 1982. Resources of Tunas and Related Species and their Fisheries in the Indian Ocean. C.M.F.R. Institute (ICAR) Cochin-18, India. CMFRI Bulletin 32 : pp 1-174.
- STRANSBURG, D. W. AND H. S. H. YUEN 1958. Preliminary results of underwater observations of tuna schools and practical applications of these results. *Proc. Indo-Pacific Fish. Coun.* 8 (5) : 84-9.

- *STRANSBURG D. N. AND H. S. H. YUEN
1960. Progress in observing tuna
underwater at Sea. *J. Cons. Perm. int.
Explor. Mer.* 26 (1) : 80-93.
- *TOMINAGA, S 1957. Skipjack behaviour and
feeding methods. Tokyo. K. Ishimaki,
298p. (In Japanese).
- TOMYAMA, T. AND TAKASHI HIBIYA 1976.
Fisheries in Japan. Skipjack and
Mackerel. Japan Marine Products photo
Materials Association.
- UDA, M. 1933. Types of Skipjack Schools and
their fishing qualities. *Bull. Jap. Sco
Sci. Fish.* 2 : 107-111.
- VAN CAMPEN, W. G. 1952. The Japanese
Skipjack Fishery. Special scientific
Report. No. 49, U. S. Department of
Interior Fish and Wildlife service.
Translated from the Japanese Language
pp. 1-67.
- VARGHESE, K. K., M. E. JOHN AND SHIVAJI
1984. Some observations on the tuna
Resources of Indian Ocean In: Important
Observations on Deep Sea fish resources
made during 1983-84. Fishery Survey
of India, Bombay : 30-33.
- YORK, A. G. 1977. Tuna Investigations - Bay
of Plenty New Zealand. 1969-71. Fish
Tech. Rep. 151, 90 pp. New Zealand
Min. Agr. Fish. Wellington.
- YUEN, H. S. H. 1959. Variability of skipjack
response to live bait. *Fishery Bull U. S.
Fish Wildl. Serv.* 60 (162) : 147-60.
-
- * Original not referred

PRESENT STATUS OF OIL SARDINE FISHERY AT KARWAR

G. G. Annigeri

Central Marine Fisheries Research Institute, Karwar Research Centre, Karwar

ABSTRACT

The average annual yield of traditional gears (Rampan and Yendi) from 1967 through 1982 for 16 years is 146.4 t. Consequent to introduction of purse seiners from 1976, the average catch for the 10 year period from 1976 through 1985 for oil sardine increased to 2273 t at Karwar showing nearly 15.5 times more yield than the former period. This paper discusses whether this new development is a boon to the fishery or whether it has an adverse impact on the fishing stocks. For this purpose, the average standing crop and average annual stock of oil sardine in the fishing grounds for a year were estimated. An estimate on yield-per-recruit and the maximum sustainable yield (MSY) for varying fishing intensities and instantaneous natural mortalities was made to understand the extent of fishing stress on the resource. A closer scrutiny of all India catch data of oil sardine and mackerel from 1976 to 1980 when 35 to 400 numbers of purse seiners were introduced respectively, showed that the premechanisation period (1970-75) accounted for better annual average catch than the purse seine era (1976-1980) as the catch per day per purse seine declined. The optimum level of exploitation and the adverse effects on the stocks if they are indiscriminately exploited without proper planning are discussed in the paper.

INTRODUCTION

Oil sardine forms one of the important components of the marine fishery resources

of India. For better understanding and planning future research, the extent the resource exploited, endurance of its increased exploitation in proportion to increased number of

mechanised vessels are the mile stones in assessing stress on the fishery. There is need to study these aspects for oil sardine fishery which is exploited by purse seiners at Karwar, on the West Coast of India. It would be highly essential to determine the magnitude of the populations, whether the rate harvested is small or large, whether any conservation measures are required if the rate of harvest is above that of the maximum sustainable yield (MSY). The exploitation rate (U) was calculated by deriving Z (instantaneous total mortality rate) by Beverton and Holt (1956) method, length converted catch curve method and age composition method. As the oil sardine is short lived species, life span appears to be 3-4 years. On the assumption that 99% fish do not survive beyond this age (t max) the M (natural mortality) on the annual basis is 1.0172. The M for oil sardine, derived from age composition study of 1.0442 does not deviate much from the above method. Studies on yield-per-recruit for three levels, 1.5, 1.0 and 0.5 of natural mortalities (M) during the exploitation phase of the fishery indicate maximum yields of 21 gm, 28 gm and 44 gm at the fishing mortality rates of 3.7, 2.1 and 0.9 respectively. Studies on annual and standing stocks were made and they are presented in the accompanying tables below.

INVESTIGATIONS ON THE RESOURCES OF OIL SARDINE CATCH TRENDS AND EFFECT OF MECHANISATION ON TRADITIONAL GEARS

Introduction of purse seiners on commercial basis in the mid seventies has increased the marine fish catches to the tune of 63% over the average catch of 1.03 lakh tonnes (mostly by the indigenous gears) of past decade in Karnataka. In indigenous gears the catch of oil sardine at Karwar ranged from 0.05 t in 1983 to 650 t in 1968. The catch showed the main peak of 650 t in 1968, with minor peaks of lesser intensities in 1970 (153 t), 1972 (186 t), 1976 (369 t), 1978 (267 t) with lean years in between these, ultimately stooping to very low levels from 29 t in 1979

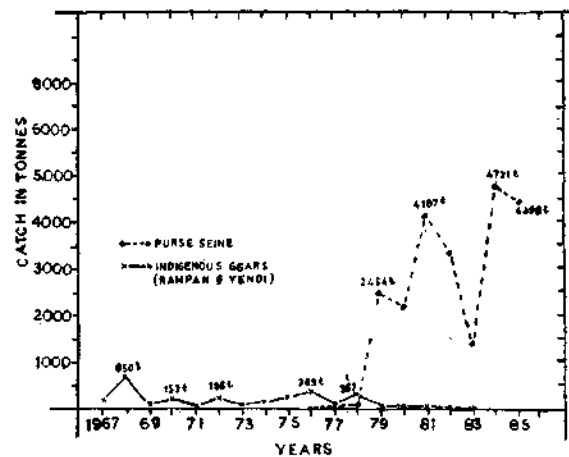

Fig. 1 Trend of oil sardine catches at Karwar during 1967-85

to 0.06 t in 1983 (Fig. 1). This declining trend in production by traditional gears from 1978 to 1983 and on, is marked by the introduction of new purse seine era and catches improved considerably with increasing peaks in 1979 (2454 t), 1981 (4107 t) and 1984 (4731 t) and troughs in 1980 (2158 t), 1982 (3360 t), 1983 (1386 t) and 1985 (4498 t). From 1979 onwards till 1985 the catch of oil sardine in purse seiners at Karwar never went below 1400 t (Fig. 1). But indigenous gears (Rampan and yendi) never exceeded 650 t. It is worth to investigate, whether this increased exploitation by fishing by the purse seiners has any adverse effect on the population. It is observed that the fishery by the indigenous gears is utter failure consequent to the introduction of purse seiners in the Karwar waters. Now the fishery has been based on purse seiners. If such situation is there, what would be the quantity to be harvested?

For this purpose, Schaefer's model (1957) was fitted to the oil sardine caught in purse seiners to the effort and relative abundance of catch to make a broad estimate on the maximum sustainable yield and effort required for this yield from 1979 through 1985. The constants 'a' and 'b' ($Y = a - bf$) were 1409.7 and - 0.1315 respectively, where f is effort spent and Y is the relative abundance. From this, the MSY for oil sardine fishery at Karwar is 377 t and the effort for this is 5358 unit days of operations.

ESTIMATES OF INSTANTANEOUS TOTAL MORTALITY FOR SEPARATING F (FISHING MORTALITY) AND M (NATURAL MORTALITY) FOR PURSE SEINE FISHERY

Here no need arises for describing detailed methodology for estimating total instantaneous rates of mortality. The methods are well known to most of the fishery biologists. The methods used for estimating the 'Z' were Beverton and Holt (1956), Length converted catch curve method and the Age composition method.

Sekharan and Dhulkhed (1963) found the value of Z as 1.66 for oil sardine for 1957-63 off Mangalore area. Based on the effective life span, M was 1.12. From these 'F' and 'U' (exploitation rate) were 0.26 for oil sardine. The 'Z' value obtained by Banerji (1973) on the West coast was 1.42 and M=0.67. The exploitation rate 'U' becomes 0.48 when Z of 1.66 was used. These 'M' values are used to calculate 'U' in the present account.

Table 1.

'Z' values estimated by different methods for oil sardine at Karwar from purse seiners.

Years	Beverton and Holt method	Length converted catch curve method.	Age composition method
1976	4.4322	1.7749	1.4615
1980	5.6702	5.0755	2.1340
1981	3.3148	0.1959	2.3530
1982	3.0209	3.2380	2.7665
1983	3.2545	3.9964	0.1415
1984	2.4642	1.9777	1.0006
1985	3.2973	3.0067	1.3810
Average for 1979-85	3.6363	2.7522	1.6054

'M' calculated on the basis of effective life span of oil sardine was 1.0172. The 'M' estimated from the age composition of the purse seine fishery was 1.0442. As there was no linearity between Z and effort, the 'M' calculated by the age composition method was not used for calculating F, exploitation rate (U) and yields then on. Although 'M' derived by both the methods are nearer to each other, M=

1.0172 based on the effective life span of fish is followed for calculations. Sekharan (1974) states that mean value of M around 1.00, seems as more reasonable estimate.

ESTIMATION OF STOCKS OF OIL SARDINE

Estimation of annual average stock and standing stock of purse seine fishery was made by the general formula, $U = \frac{F}{F+M} (1 - e^{-Z})$, Where 'U' is annual exploitation rate, 'F' is the annual instantaneous fishing mortality rate and 'M' is the instantaneous natural mortality rate. The annual average catch of oil sardine on All India basis during 1979 through 1984, amounts to 178095.5t. The average and standing stocks for average Z values from 3 methods with M=1.0172 one given in Table 2.

a) STOCKS ON ALL INDIA BASIS

The annual average stock and standing stocks in the fishing grounds are 387978 t and respectively.

Taking Z and M values for present study of Sekharan (1974) and Banerji (1973), the stocks for 1979-1984 (with All India average catch of 178,095.5 t, may be estimated as below:

From the table 3, it is observed that when natural mortality rates 1.0172, 1.12 and 0.67 are used with 'Z' values of the present account, the pooled averages of annual stock and standing stock approach to 392,213 t and 150,688 t respectively showing 4235 t more average stock and 7122 t less standing stock than the averages of Table 2, when M=1.0172, alone was used. This is because of differences in the rates of exploitation under different situations stated above.

When 'Z' values of Sekharan (1974) and Banerji (1973) as shown in Table 3, for 3 levels of instantaneous natural mortality rates are taken, the resultant pooled annual average and standing stocks for Z=1.66 are 537,506 t and 262,254 t and for Z=1.42, they are 794,785 t and 424,419 t respectively.

Table 2.

Average annual and standing stocks (in tonnes) of oil sardine (All India) when $M=1.0172$ during 1979-1984 period.

Method of estimate	Z	F	Annual average stock (YIU)	Annual average standing stock (YIF)	Remarks
Beverton and Holt (1956)	3.6363	2.6191	253,951	67,999	Stock estimates were made for a Single M value
Length converted catch curve method	2.7522	1.7350	301,754	102,649	
Age composition	1.6054	0.5882	608,250	302,781	
Average of above methods			387,978	168,810	

Table 3.

Annual average and standing stocks of oil sardine (All India) using three, $M=1.0172$, $M=1.12$ (Sekharan, 1974) and $M=0.67$ (Banerji, 1973) values.

Z	F	M	Annual average stock (tonnes)	Annual standing stock (tonnes)	Remarks
3.6363	2.6191	1.0172	253,951	67,999	Mechanised period by purse seiners
	2.5163	1.12	264,315	70,777	
	2.9663	0.67	224,245	60,040	
2.7522	1.7350	1.0172	301,754	102,649	
	1.6322	1.12	606,385	109,114	
	2.0822	0.67	251,441	85,532	
1.6054	0.5882	1.0172	608,250	302,781	
	0.4854	1.12	737,150	366,905	
	0.9354	0.67	342,425	190,395	
Average (Mechanised period)			392,213	150,688	
1.66 (Z after Sekharan 1974)	0.6428	1.0172	567,907	277,062	Non mechanised period by the traditional gears.
	0.54	1.12	675,804	329,806	
	0.99	0.67	368,728	179,894	
Average			537,506	262,254	
1.42 (Z after Banerji, 1973)	0.4028	1.0172	827,966	442,144	
	0.30	1.12	1111,707	593,652	
	0.75	0.67	444,683	237,461	
Average			794,785	424,419	
Average (Non-mechanised period)			666,146	343,337	

From the present study, it is noticed that in the total mortality range of 1.6054 to 3.6353 the annual average stock and annual average standing stock are 391 t, 213 t and 150,688 t in the fishing grounds; but when 'Z' values were low (1.66 and 1.42), the pooled annual average stock and annual average standing stock are 666,146 t and 343, 337 t respectively in the fishing grounds.

It may be mentioned here that Sekharan (1974) estimated U as 0.26 taking $M=1.12$ and $F=0.54$ and the annual average and standing stocks estimated by him were 810,000 t and 390,000 t respectively when the annual average catch of oilsardine on the West Coast during 1960-1971 was 210,000 t. He calculated U of 0.48 for $Z=1.66$ taking Banerji's value of $M=0.67$ and from this annual average stock in the fishing grounds of 440,000 t and the standing stock of 210,000 t. In the present study, the annual stock and standing stock show lower values than the ones estimated by the above authors and the exploitation rates were higher in the fishing grounds by the purse seiners. The higher annual average and standing stocks during the premechanised period may probably be due to better recruitment to the fishery than the mechanised period.

b) STOCKS OF OIL SARDINE AT KARWAR WATERS (EXPLOITED BY THE PURSE SEINERS)

From the Table 1, the average 'Z' values for the three methods are 3.6363, 2,7522 and 1.6054. From these Z, average F values, 2.6191, 1,7350, 0 5882 were found by deducting $M=1.0172$ from Z. Then the corresponding 'U' values 0.7013, 0.5902 and 0.2928 were obtained. The annual average stock and standing stock during different years are shown in Table 4 for the purse seine fishery at Karwar.

From the above table annual average stock and the annual average standing stock from 1979 through 1985 are 7063 t and 2873 t at Karwar area which are 55.5 and 52.5 times lower than those estimated for the whole West coast of India (i. e. 392213 t and 150688 t) respectively.

STUDIES ON THE YIELD-PER-RECRUIT(Y/R) OF OIL SARDINES OCCURRING IN PURSE SEINERS FOR DIFFERENT INTENSITIES OF INSTANTANEOUS NATURAL AND FISHING MORTALITIES

Yield-per-recruits for 3 levels of instantaneous natural mortality rates at 1.5, 1.0 were

TABLE 4

Annual average and standing stocks (in tonnes) at Karwar (purse seiners)

Years	Annual catch in tonnes	Annual average stock (Y/U)	Annual average standing (Y/F)	Remarks
1979	2454	6885	3160	
1980	2158	3344	1309	These stocks are the pooled averages from the three methods calculated separately as stated above sumped summed up and averaged.
1981	4107	6550	2431	
1982	3368	5365	1704	
1983	1386	1889	0542	
1984	4731	156883	97726	
1985	4498	12239	5533	
Average	3242	7063	2873	

estimated by the well known formula of Beverton and Holt (1957) which was simplified by Ricker (1958), as below:

$$Y/R = F e^{-M(tp1-tp)} \left\{ \frac{1}{(F+M)} - \sum_{n=0}^{\infty} \frac{3 e^{-nK(tp1-t_0)}}{(F+M+nK)} \right\}$$

where F = Fishing mortality, M = Natural mortality, $tp1$ = age at capture, tp = age at recruitment, t_0 = Arbitrary origin of age when fish has zero length, and Un = summation variable.

a). **YIELD AS FUNCTION OF 'F' KEEPING $tp1$ AS CONSTANT**

Fig. 2A, shows yield per-recruit calculated for $M = 0.5$. It is observed from the figure that when the fishery is exploited during November-December, when the fish are 8 to 9 months old, the maximum yield of 44-45 gm is obtained at

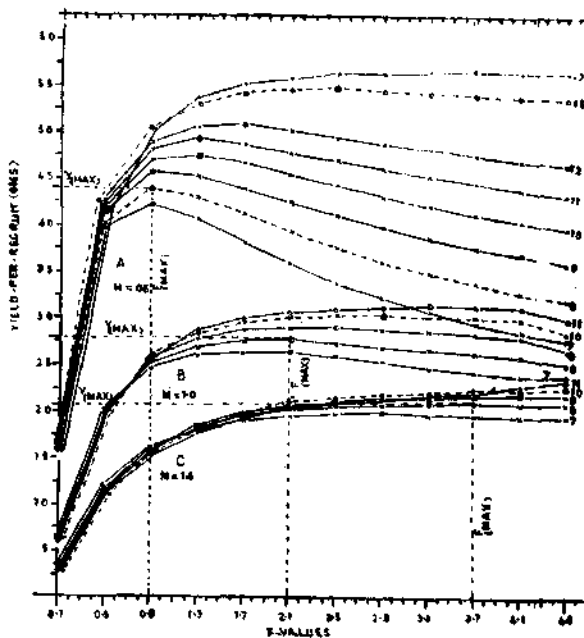

Fig. 2

$F = 0.9$, these values are Y (Max). At higher natural mortality rate when $M = 1.0$ (Fig. 2 B) the fishery at the same age and time show the maximum yield of 28-29 gm (Y Max) when F values are 2.1 and 2.5 (F Max). Y (Max) and F (Max) when $M = 1.5$, for 8 and 9 month fish in November - December period, are 21 gm at

3.7 F and 22 gm with 4.1 F respectively. Increase of natural mortality and F above 1.0 M and 2.5 F may result into less yield when compared to lower M and F values than these as stated above (fig. 2A-C).

b). **EUMETRIC YIELD AND FISHING CURVES**

Figs. 3A, B and C show eumetric yield and fishing curves for 3 levels (0.5 M , 1.0 M and 1.5 M) of instantaneous natural mortality rates. In Figures, eumetric yield curves (broken lines) are obtained by plotting the maxima of Y/R (gm) from each of all $tp1$ values against the corresponding ' F ' values. In these eumetric yield curves (Figs. 3 A, B & C) high values of Y/R

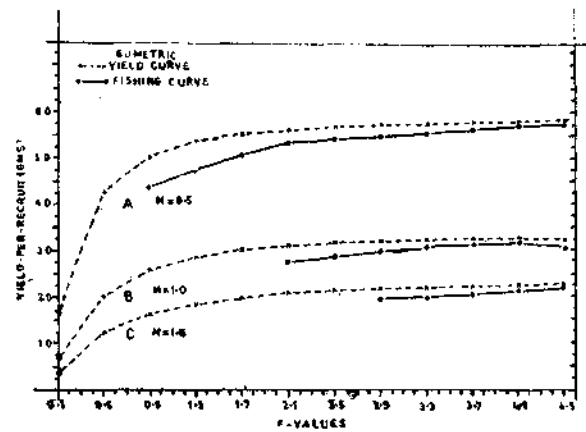

Fig. 3

(Maxima) show fall to low yield values as ' M ' increases from 0.5 to 1.5. The eumetric fishing curves which lie below the yield (mesh) curves show also same tendency for instantaneous natural mortality ranging from 0.5 to 1.5. In these curves, as the fishing intensity increases yield curves approach to asymptote and indicate no clear cut maxima.

c.) **EUMETRIC FISHING AS A FUNCTION OF AGE AT ENTRY FOR EACH LEVEL OF F , KEEPING F AS CONSTANT**

In Figures 4 A, B and C there are shown yield mesh curves for each of a number of different values of F , for each value of natural mortality for 0.5, 1.0 and 1.5, separately. It is found that as F increased, the mesh required to give the maximum yield and the quantity of that

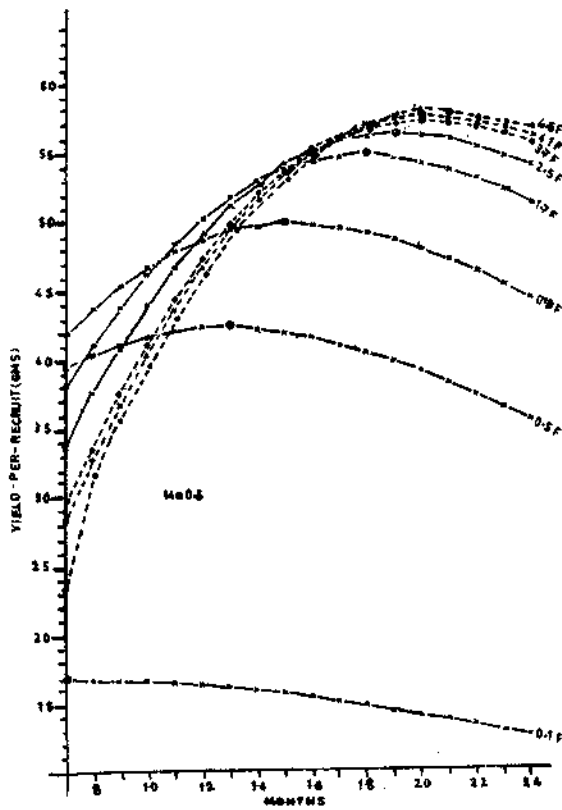

Fig. 4

yield also increases. This is still clear by the description given below.

From the Figure 4A, it would be seen that when $M=0.5$, low yields are obtained for lower F values. As F increases, yields also increase. Maximum yields are obtainable when F values are increased from 1.7 to 4.5, at the ages from

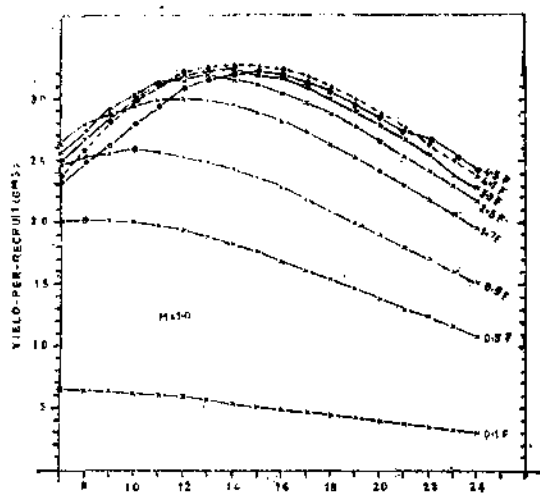

Fig. 5

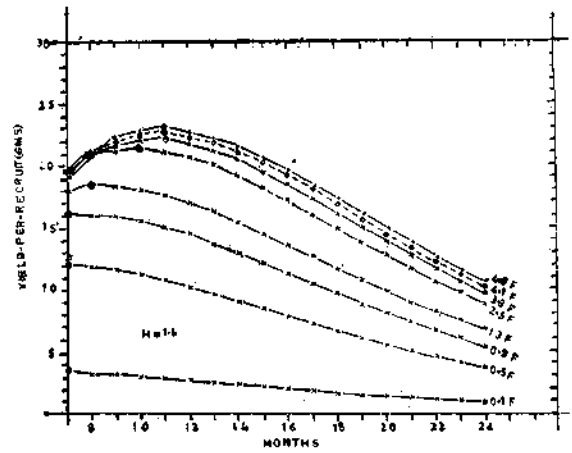

Fig. 6

18 months to 21 months (i. e. 1.5 year to 1.75 year). For $M=1.0$ also, increasing F value from 1.7 to 4.5, gives maximum yield for ages 12 months to 15 months (i. e. 1 year to 1.25 year olds) and for $M=1.5$, by increasing F values upto 4.5 show low yields for higher ages and higher yields for the lower ages (Figs. 4 A, B and C). One important feature noticed here is that as M increases higher ages tend to produce low yields and the quantity produced is also low.

GENERAL CONSIDERATIONS

This paper deals with some vital aspects of population dynamics on oil sardine fishery resources of Karwar on the West coast of India. At present the fishery is exploited by the purse seiners. As a result of this the artisanal fishery by the indigenous gears has been almost obliterated. As this paper relates to purse seine fishery of this area, attempt was made to understand whether catches are sustainable or not. Data fitted to Schaefer's model indicate that the average annual sustainable yield (MSY) for oil sardine fishery by purse seiners at Karwar is 3775 t and effort for this is 5358 unit days of operations for an year. As seen from the Table 4, the average annual harvest of 3242 by the purse seiners, is less than the MSY level and it is well within the limit at Karwar. Therefore, another 500 t may easily be harvested without any adverse effect on the sardine fishery here. This species is migratory and shows wide seasonal fluctuations. It is assumed that immigration into the fishing grounds and

emigration of the population from these grounds are constant. For the same set of data, it is observed that there is bound to be difference in the 'Z' estimates from one method to the other. Here three methods viz., Beverton and Holt (1956), Length converted catch curve method and Age composition method were followed for estimating 'Z' values (Table 1). The average 'Z' value for the first method was higher than that of the second and that of second was higher than the third. In such situations annual average stock and standing stock (for same source of data) are lower for higher Z values and vice versa. It is not correct to say that one method is underestimate and the other is overestimate. To solve this difficulty, the oil sardine stocks are calculated by each method, pooled and averaged for all three methods for annual average and standing stocks. They are estimated at 987978 t and 157810 t on All India basis (Table 2). These are for a single value of $M=1.072$. When 3 M values of different authors on oil sardine are chosen for above 'Z' values (Table 3), the pooled average annual and standing stocks on All India basis in the fishing grounds are 392213 and 150688 t respectively. This difference in the first and second set of values is because of difference in natural mortality rates obtained under different fishery situations in them. In the third set of Z values of different authors (Sekharan, 1974 and Banerji, 1973) the annual average and standing stocks when pooled are 666146 t and 343337 t respectively (Table 3). The average annual and standing stocks present in the fishing grounds are 7063 t and 2873 t respectively (Table 4). The average annual catch during 1979-1985 is 3242 t and this is more than the standing stock at Karwar. The reactions of fish population to fishing and natural mortalities are remarkable and also for changes in its environment. Such losses from population are compensated by accessions to it, and restore balance under such changing conditions, as fish populations have self regulating mechanism and this resiliency of population is generally observed in any sustained fishery. Studies on yield-per-recruit of oil sardine at 3 levels of natural mortality rates show that fishery in the exploitation phase, with $M=0.5$, the Y (Max) and F (Max) being 44-45 gm and 0.9 F respecti-

vely. As 'M' values increase to 1.0 and 1.5 in the exploitation phase, Y (Max) and F (Max) are 28-29 gm and 2.1 to 2.6 F and 21-22 gm and 3.7 F-4.4 F respectively, showing the reduction of yield as natural mortality increases. This trend is also noticed in eumetric yield and fishing curves (Figs 3A, B and C). By keeping F constant and changing tp 1 (age at entry) the mesh required to give the maximum yield for 0.5 M, 1.0 M and 1.5 M was calculated. For 0.5 M, increase of F from 1.7 to 4.5 at ages 1.5 year to 1.75 year showed better yield. For $M=1.0$, same increase of F gave maximum yield for ages 1 year to 1.25 year fish. Finally for $M=1.5$, the same increase of F again showed low yields for the higher ages and high yields for lower ages (Figs. 4 A, B and C).

Now, the idea centres round whether mechanisation has become boon to the fishing industry or not. Purse seines in 1970 were 4 in numbers. This number increased to 35 in 1976, on the West Coast. During 1980, there was unexpected sudden rise to 400 number. In the subsequent years after 1980, more numbers were added every year. It would be of interest to note that the average catch of oil sardine from 1960 to 1975 which is described as non-mechanised period was 190026 t and the period 1976 to 1984 which is characterised by the mechanised one with more than 400 purse seines operating showed the annual average catch of 172, 894 t which is far below the average catch obtained by the traditional gears alone. This has indicated that, mechanisation has not brought any success by increasing more fleet strength in the fishing grounds. In fact, this has made the average catch to decline. Such situation reflects on the standing stock present in the area. According to Sekharan (1974) and Banerji (1973), annual average standing stocks of oil sardine are 390,000 t and 210,000 t respectively, when the fishery was exploited exclusively by the traditional gears during 1960-1971 and recruitment to the fishery was better as judged from the average catch during this period. They also observed lesser exploitation rate. In the present study during 1979-84, the fishery exploited by the purse seiners shows higher rate of exploitation (U) and annual average standing stock approaches to 157810 tonnes. Therefore,

introduction of more number of purse seiners beyond the present MSY level (i. e. 2.1 F when $M=1.8$), would definitely imbalance the standing stock and then consequently the rate of natural increase, resulting into depletion of the stocks. According to Banerji (1973), the average F of 0.75 would give the maximum yield-per-recruit (Y/R) when $M=0.67$ for oil sardine on the West coast of India. This may be compared to above fig 0.9 F when $M=0.5$. The catches of purse seiners diminishing at present when compared to those in 1976 or soon after when their number was limited to very few. The optimum catch for the present rate of fishing (2.1 F when $M=1.0$), is 331400 t, which shows higher value when compared the optimum sustainable yield, of 213,000 t for oil sardine on the West Coast of India (Banerji, 1973). Therefore, great care should be exercised in regulating the number so as to prevent the harmful effect on the oil sardine resources of the country which should be conserved and renewed by its judicious exploitation.

ACKNOWLEDGEMENTS

The author is grateful to Dr. P. S. B. R. James, Director, C. M. F. R. Institute, Cochin for his guidance and encouragement. His thanks are also due to Shri K. V. Narayana Rao, Project Leader, Mangalore R. C. of C. M. F. R. I. Institute, Mangalore and Shri M. Srinath, Scientist for their timely help in preparing this account.

REFERENCES

- BANERJI, S. K. 1973. An assessment of the exploited pelagic Fisheries of the Indian seas. In *Proceedings of the symposium on living resources of seas around India: 114-136. Spec. Publ. CMFRI, Cochin (issued in 1973)*
- BEVERTON, R. J. H. AND S. J. HOLT. 1956. A review of the methods for estimating mortality ratio in exploited fish populations with special reference to sources of bias in catch sampling. *Rapp. Cons. Explor. Mer.*, 140 (1) : 67-83.
- BEVERTON, R. J. H. AND S. J. HOLT. 1957. On the dynamics of exploited fish populations. *Fishery Invest. Lond. Series 2 (19)* : 533 pp.
- RICKER, W.E. 1958. Handbook of computations for biological statistics of fish populations. *Bull. Res. Board Can.* 119 : 382 pp.
- SCHAEFER, M. B. 1957. A study of the fishery for Yellow fin tuna in the eastern tropical Pacific Ocean. *Inter - Am. Trop. Tuna Comm. Bull 2* : 247-268.
- SEKHARAN, K. V. and M. H. DHULKHED 1963. On the oil sardine fishery of Mangalore zone during the years 1957-63. *Indian J. Fish.*, 10 A (2) : 601-626.
- SEKHARAN, K. V. 1974. Estimates of the stocks of oil sardine and mackerel in the present fishing grounds off the West coast of India. *Indian J. Fish.*, 21 (1) : 177-182.

PROBLEMS OF IDENTIFICATION AMONG SPECIES OF *SARDINELLA*

K. P. Sivakumaran, M. Manickasundaram and V. Ramaiyan
*Centre of Advanced Study in Marine Biology,
 Annamalai University, Parangipettai 608502*

ABSTRACT

In spite of several recent studies, confusion still surrounds on the identification of few Indian clupeoids such as *Sardinella*, *Ilisha* and *Thryssa* because of their morphological similarity between species, which has severely restricted the useful biological studies (Babu Rao, 1962; Whitehead, 1973; Ramaiyan and Whitehead, 1975; and Wongratana, 1983).

Of all the clupeids, the identification of the species of *Sardinella* by various authors based on meristic and morphometric characters is often confusing. The identity of *S. longiceps*, *S. clupeioides*, *S. leiogaster*, *S. sirm* based on few meristic and morphometric characters is relatively easy however, the same characters are not satisfactory for *S. albellia*, *S. brachysoma*, *S. dayi*, *S. fimbriata*, *S. gibbosa*, *S. melanura* and *S. sindensis*.

The present study demonstrating the unsuitability of meristic and morphometric characters for the identification of the species of *Sardinella* cautions the possibility of mixed material in future biological investigations on *Sardinella*.

INTRODUCTION

Clupeoid fishes particularly sardines, herrings and shads although comparatively smaller in size, occur in large shoals contributing to important fisheries of the world such as the British herrings, pilchards, Peruvian anchoveta, Pacific sardines and lesser sardines and Indian oil sardine to Indian fisheries. Knowledge on the systematics, fishery and biology of the clupeoid resources is an important prerequisite for their proper understanding and rational exploitation. In India, the clupeoid fishes including the lesser sardines in general and particularly the oil sardine *Sardinella longiceps* contribute much to Indian pelagic fisheries.

In spite of several recent studies (Wongratana, 1983; Talwar and Kacker, 1984 and Whitehead, 1985) confusion still surrounds on the identification of species of Indian clupeoid fishes such as *Sardinella ilisha* and *Thryssa*, because of their morphological similarity between species which has severely restricted the useful biological investigations.

The identification of the species of *Sardinella* by various authors, based on many characters is often conflicting and totally

confusing. Hence, the present paper, while demonstrating the unsuitability of the meristic and morphometric characters for the identification of *S. gibbosa*, *S. fimbriata*, *S. brachysoma*, *S. sindensis*, *S. albellia* based on material collected from parangipettai, suggests means to overcome this difficulty.

MATERIAL AND METHODS

The material for the present study consisting of specimens of oil sardine (*Sardinella longiceps*) and lesser sardines (*S. dayi*, *S. albellia*, *S. brachysoma*, *S. fimbriata*, *S. sindensis*, *S. gibbosa* and *S. melanura*) were collected from parangipettai fish landing centre. The specimens were obtained thrice a week from the commercial catches operated by gillnets for a period of 5 months from April to August 1986. Only standard morphometric measurements (total length, standard length, head length and body depth) and meristic counts (lower gill rakers on first arm and abdominal scutes) were made on all the specimens obtained. The size range of the specimen varied from 60 mm-135 mm in S.L. The morphometric measurements were made of the left side of the specimen.

TABLE - 1.
*Ranges of morphometric and meristics of various species of Sardinella
as recorded by various authors.*

Name of the species	Authors Name	Number of Gill rakers on lower limb of first gill arch.	Number of belly scutes	Depth of body (% of S. L.)
(1)	(2)	(3)	(4)	(5)
1. <i>Sardinella albella</i>	Whitehead and Wongratana (1983)	41-68	30-32	25-40
	Talwar and Kacker (1984)	40-67	31-32	24-39
	Whitehead (1985)	41-68	29-33	25-40
	Present Study	44-61	29-33	25-36
2. <i>Sardinella brachysoma</i>	Whitehead and Wongratana (1983)	—	—	—
	Talwar and Kacker (1984)	49-65	29-32	28-40
	Whitehead (1985)	48-67	29-32	30-39
	Present study	50-66	29-32	30-38
3. <i>Sardinella dayi</i>	Whitehead and Wongratana (1983)	88-132	31-32	34-38
	Talwar and Kacker (1984)	80-132	31-32	34-38
	Whitehead (1985)	88-126	30-32	—
	Present Study	—	—	—
4. <i>Sardinella fimbriata</i>	Whitehead and Wongratana (1983)	54-89	29-32	25-35
	Talwar and Kacker (1984)	53-82	29-32	25-35
	Whitehead (1985)	54-82	29-33	25-34
	Present Study	56-82	29-32	26-34
5. <i>Sardinella gibbosa</i>	Whitehead and Wongratana (1983)	40-68	32-34	22-32
	Talwar and Kacker (1984)	38-65	31-35	22-31
	Whitehead (1985)	45-59	32-34	24-30
	Present Study	40-64	31-34	24-31
6. <i>Sardinella melanura</i>	Whitehead and Wongratana (1983)	38-74	28-30	30
	Talwar and Kacker (1984)	38-74	28-30	25-30
	Whitehead (1985)	38-74	28-30	27-30
	Present study	39-72	28-30	27-30
7. <i>Sardinella sindensis</i>	Whitehead and Wongratana (1983)	38-77	31-34	21-36
	Talwar and Kacker (1984)	—	—	—
	Whitehead (1985)	38-77	31-34	21-35
	Present Study	39-72	31-33	21-23
8. <i>Sardinella jussuie</i>	Whitehead and Wongratana (1983)	88-101	30-34	28-37
	Talwar and Kacker (1984)	—	—	—
	Whitehead (1985)	88-126	31-32	28-37
	Present Study	—	—	—

OBSERVATION AND DISCUSSION

The ranges of the morphometric and meristic data of the Sardines studied presently are provided in Table 1 along with the ranges observed by earlier authors. The objective of the present study is to highlight the unsuitability of the morphometric and meristic data alone for the proper identification of the species of *Sardinella* because of their morphological similarity between species. Of the species of *Sardinella* studied *S. longiceps* could easily be identified based on its longer head length (29-35% S. L.). Similarly, the jet black caudal fin tips distinguish *S. molanura* from all other species of *Sardinella*, however the identity of other species based on morphometric and meristic characters is not always easy.

The meristic counts (abdominal scutes and lower gillrakers) of *S. dayi* overlap with that of *jessieui*, though reported to occur along western coasts of India from Bombay to Sri Lanka though not recorded from parangipettai coast. However, Wongratana (1983) has separated the two species based on abdominal scutes, but his range of scute count overlap. Further, there is no significant variation either in body depth or in lower gillraker counts between these two species.

The abdominal scutes range from 29-34 in the various species of *Sardinella* (*S. albella*, 29-33, *S. brachysoma*, 29-32, *S. fimbriata*, 29-33, *S. gibbosa*, 31-35 and *S. sindensis* 31-34) as reported by Wongratana (1983), Talwar and Kacker (1984) and Whitehead (1985), however the separation of species based on abdominal scutes is definitely not easy in routine analysis.

The variation in the range of lower gillrakers is often employed for the identification of the above mentioned species. The lower gillrakers range from 38-68 in various species of *Sardinella* excepting *S. dayi* (80-132) and *S. jussieni* (88-126), however, the range of lower gillrakers in *S. albella* (40-68), *S. brachysoma* (48-67), *S. fimbriata* (53-89), *S. gibbosa* (33-68), *S. sindensis* (38-77) overlap with each other indicating their unreliability in

separating the species. Depth in percentage of standard length has often been employed for separating the species which is not always easy. Perhaps it could be successfully used to separate the species if the non-overlapping nature is established employing ontogenetic series of specimens as suggested by Whitehead (1985).

The nature of the pattern of the striae on scales has been attempted by earlier authors (Whitehead, 1985) to separate the morphologically similar species of *Sardinella*, however, due to lack of consistency in the pattern, this too can not be successfully employed for the separation of species. As far as the vertical striae on scales are concerned *S. brachysoma* is distinct in which the striae are continuous at the centre whereas in *S. albella*, *S. fimbriata*, *S. gibbosa* and *S. sindensis* the striae pattern is almost exactly similar.

Because of the overlapping nature of the morphometric and meristic characters of sardines between species it is suggested that future investigations on the biology of any particular species of sardine should be carefully planned because of the possibility of mixed material. Thus the problem of identification of morphologically similar species such as sardines is very acute and this may perhaps be solved to some extent either by employing ontogenetic series of specimens of the species concerned as suggested by Whitehead (Per com.) or by developing suitable methods to rear the marine fish larvae as suggested by Kuronuma and Fukuso (1987).

ACKNOWLEDGEMENT

The authors wish to thank Prof. V. K. Venugopalan, Director, C A S in Marine Biology, for providing the facilities. The first and second authors are grateful to the UGC for financial assistance.

REFERENCES

- M. BABU RAO 1962. Studies on the clupeoid fishes of the Godaran Estuary. Ph. D. Thesis, Andra University. 223 p.

- K. KURONUMA and K. *Fukusho* 1987. Rearing of Marine Fish larvae in Japan. Ottawa, Ont., IDRC., 109 p.
- V. RAMAIYAN AND P. J. P. WHITEHEAD 1975. Notes on Indian species of *Hisha* (Pisces: Clupeidae) J. mar. biol. Assoc. India, 17, (1) : 187-198.
- P. K. TALWAR AND R. K. KACKER 1984. Commercial sea Fishes of India, Publ. by Zoological Survey of India. Calcutta 997 p.
- P. J. P. WHITEHEAD 1973. A synopsis of the clupeoid fishes of India. J. mar. biol. Assoc. India, 14 (1) : 160-256, figs. 1-68.
- P. J. P. WHITEHEAD AND T. WONGRATANA 1984. FAO species Identification sheets for Area 51, Western Indian Ocean, 5 vols.
- P. J. P. WHITEHEAD 1985. FAO Fisheries synopsis. Clupeoid Fishes of the world, FAO, Rome. Vol. 7.
- T. WONGRATANA 1983. Diagnosis of 24 New species and proposal of a new name for a species of Indo-Pacific clupeoid fishes. Jap. Jour. of Ichthy. Vol. 29, No. 4, 385-407, Figs. 1-25.

PRESENT STATUS OF PERCH FISHERY RESOURCES IN INDIA AND ITS PROSPECTS

H. Mohamad Kasim, K. M. S. Ameer Hamsa and P. Sam Bennet
Central Marine Fisheries Research Institute, Cochin - 682 031.

ABSTRACT

The perch resources and fisheries in India have been dealt with. As seen from the Statewise perch production during 1969-1981, on an average 27,184 tonnes of perches were landed in India with fluctuation from 12,865 in 1969 to 49,312 in 1978. The gearwise and Statewise perch production from 1982-83 to 1984-85 indicates that the mechanised units contributed 72.4 % and non-mechanised 27.6 %. Among mechanised units, the trawlers have landed the major portion of the catch (68.4 %). The Statewise species composition of perch landings indicate that the threadfin breams formed more than 50% of the catch. During 1982-83 and 1983-84, the perch production of Tamil Nadu was higher than all other states, whereas during 1984-85, Kerala was the first in perch production followed by Andhrapradesh and Tamil Nadu. The different groups of perches landed by trawl and gill net units at different important landing centres on the east and west coast of India show that in all the centres the catch rates of trawlers were higher. The higher catch rate in trawl net operations in Saseons Dock and New Ferry Wharf was due to voyage fishing for more than a day.

Among threadfin breams, *Nemipterus japonicus* and among pig face breams, *Lethrinus nebulosus* are the dominant species. The growth, mortality rates, optimum age of exploitation, potential yield per recruit and yield per recruitment at different combination of age at first capture and fishing mortality coefficients of these species have been dealt with in detail. The prospects of the perch fishery by commercial trawlers and the possible increase in production by the introduction of pair trawling with high opening trawl net in Gulf of Mannar is discussed.

INTRODUCTION

Perches are an important marine fishery resource, but exploitation of this is limited to

the narrow belt of this continental shelf of about 50 m depth covering an area of 1,80,539 sq. km. Annually on an average 59,215.6 t of perches are landed by different types of gears

operated by both mechanised and non-mechanised vessels along east and west coasts of India (Jones and Banerji, 1973; Anon, 1981, 1983, 1986). The common perches landed in India belong to thirty seven genera of five different groups i. e., 1. rock cods, 2. snappers, 3 pig-face breams, 4. threadfin breams and 5. other perches. Considering the commercial and economic importance of this resource a systematic study was undertaken to investigate the fishery of perches and the population dynamics of the dominant perch, *Lethrinus nebulosus* at Tuticorin.

METHODS

The data on the Statewise, gearwise and centrewise perch landings and species composition of these landings were obtained from the Fishery Resource Assessment Division which employs multistratum random sampling method for collecting the catch statistics of different marine fishery resources in India.

Weekly observations were made to collect the data on the gearwise catch, effort, species composition of perch landings and length frequency of dominant species *L. nebulosus* (Forsk.) at Tuticorin. The length-weight relationship of *L. nebulosus* was obtained by least square method (Snedecor and Cochran 1967). The growth estimates of *L. nebulosus* and *N. japonicus* were obtained by the integrated modal progression analysis (Pauly, 1980) and Bagenal (1955) method. The natural mortality coefficient (M) was estimated from the maximum life span of the species as per Sekharan (1974) and also by "independent method" (Pauly, 1980). The total mortality coefficient (Z) by Beverton and Holt (1956) method, the gear selection factor by the catch curve method (Pauly, 1984) and the yield per recruitment by the method of Beverton and Holt (1957) simplified by Ricker (1958).

PERCH FISHERY

Perches are caught by different types of gear such as trawl net, drift and bottom set gill net, hooks and line, fixed bag net, purse seine, shore seine, boat seine, traps etc., operated

by various kinds of mechanised and non-mechanised craft all along the east and west coast of India.

Catch and effort: During 1961-65, perches formed on an average 1.47% of the marine fish catch and were the most abundant in Madras State (Tamil Nadu), where they formed 4.1 % of the marine fish landings, Kerala, Maharashtra and Andhra ranking next in the order given (Rao, 1973). The all India perch and total marine fish landings for the period from 1969-1981 indicate that perches formed on an average 2.2 % of the total marine fish catch. The perch catch increased steadily from 12,865 t in 1969 to 49,312 t in 1978 and the statewise annual average perch production during that period was 11,341 t in Kerala, 6,830 t in Tamil Nadu, 2,749 t in Maharashtra, 2,504 t in Andhrapradesh, 2,227 t in Gujarat, 496 t in Pondicherry, 404 t in Karnataka, 257 t in Goa, 170 t in Lakshadweep, 153 t in Andamans, 146 t in Orissa and 46 t in West Bengal. During 1979-1981 the landing fluctuated between 31,325 and 38,541 t and during 1982-1985 annual average perch production was 59,215.6 t constituting 3.5 % of the annual average marine fish production in India.

The gearwise and statewise perch production during 1982-85 in India indicate that the mechanised units contributed 72.4 % and non-mechanised 27.6 %. Among mechanised units, the trawlers have landed the major portion of the catch (68.4%). The order of average perch production among different states during 1982-85, Kerala 17,106 t Tamil Nadu 12,324 t, Andhrapradesh 9,230 t, Gujarat 6,689 t, Maharashtra 6,508 t Karnataka 2,623 t Goa 1,474 t, Pondicherry 1,181 t, Orissa 1,135 t and West Bengal 66 t. Gearwise average annual CPUE of perches landed in different states indicate that the catch rate of trawl net was higher than the rest of gears and it was 52.5 kg in Gujarat, 40.98 kg in Andhrapradesh, 39.2 kg in Kerala, 36.3 kg in Maharashtra, 27.9 kg in Pondicherry and 10.5 kg in Tamil Nadu. The catch rates of drift gill net in Andhrapradesh and of hook and line in Tamil Nadu were higher than the rest of the states.

Catch composition: The common perches landed in India belong to thirty seven genera of five important groups i. e., Rock cods: *Holocentrus Serranus*, *Epinephelus* (Serranidae), 2. Snappers: *Aprion*, *Pristipomoides*, *Lutianus* (Lutianidae), 3. Pig face breams: *Lethrinella*, *Lethrinus* (Lethrinidae), 4. Threadfin breams: *Nemipterus* (Nemipteridae), 5. Others: *Lates* and *Psammo-perca* (Latidae), ambassids (Ambassidae), *Peletes*, *Eutherapon*, *Therepon*, (Theraponidae), *Priacanthus* (Priacanthidae), *Apogon*, *Apogonichthys* (Apogonidae), *Sillago* (Sillaginidae), *Lobotus* (Lobotidae), *Pentaprion*, *Gerres*, *Pertica* (Gerriidae), *Pomadasyd* (Pomadasyidae), *Scolopsis* (Scolopsidae), *Diagramma* (Plectorhynchidae), *Argyropes*, *Acanthopagrus* (Sparidae), *Ephippus* (Ephippidae) *Platex* (Platacidae), *Drepane* (Drepanidae), *Pomacentrus*, *Amphiprion*, *Abudefduf* (Pomacentridae), *Siganus* (Siganidae), *Acanthurus* (Acanthuridae) *Kurtus* (Kurtidae) etc.

The statewise catch composition of these major groups of perches indicates that threadfin breams formed 51.5% of the catch, snappers 5.8%, rock cods 4.5%, pig face breams 3.7% and the rest by other perches

(34.5%). Out off annual average of 30,488.3 t of threadfin breams, Kerala alone landed 13,018t (Table 1). Among the threadfin breams *Nemipterus japonicus* is the dominat species, though other species *N. tolu*, *N. marginatus*, *N. hexodon* and *N. mesoprion* also support the fishery to certain extent. The different groups of perches landed by trawl net, gill net, purse seine, hooks and line and dol net units at different landing centres on the east and west coast of india show that in all the centres the catch rates of trawlers were higher than the other units. The higher catch rate of trawlers along the Andhra coast declined along the Tamil Nadu coast and then it increased along the west coast from Kerala to Maharashtra: The highest catch rate in trawl net operations in Sasoon Dock and New Ferry Wharf was due to voyage fishing for more than a day.

Fishing at Tuticorin: Perchas are caught by different types of gear such as trawl net, drift and bottom set gillnets, hooks and lines etc. Operated by various kinds of mechanised and non-mechanised crafts along Tuticorin coast. The monthwise catch composition of perches landed by trawlers during 1984-85 to 1986-87 is given in Tables 2, 3, and 4. On an average

TABLE 1.
Statewise average annual landings of different groups of perches (in tonnes) during 1982 - '85.

STATE	ROCK CODS	SNAPPERS	PIG FACE BREAMS	THREAD FIN BREAMS	OTHERS	TOTAL	%
WEST BENGAL	5.7	—	—	—	60.3	66.0	0.1
ORISSA	5.5	15.5	20.5	626.0	467.5	1135.0	1.9
ANDHRA PRADESH	16.0	1461.0	4.3	2338.7	5410.0	9230.0	15.6
TAMIL NADU	1322.0	904.0	2019.0	3162.3	4916.7	12324.0	20.8
PONDICHERRY	13.5	7.3	21.3	568.5	570.4	1181.0	2.0
KERALA	399.3	125.7	89.0	13018.0	3474.0	17106.0	28.9
KARNATAKA	41.0	19.7	6.3	2059.0	497.0	2623.0	4.4
GOA	210.0	3.0	0.5	978.5	282.0	1474.0	2.5
MAHARASHTRA	224.0	279.7	8.0	4779.3	1217.0	6508.0	11.0
GUJARAT	437.7	605.3	49.7	2358.0	2638.3	6689.0	11.3
ANDAMANS	—	—	—	—	671.3	671.3	1.1
LAKSHADWEEP	—	16.3	—	—	192.0	208.3	0.4
TOTAL	2674.7	3437.5	2218.6	30488.3	20396.5	59215.6	—
%	4.5	5.8	3.7	51.5	34.5	—	—

TABLE 2

Perch landings (in tonnes) during 1984 - '85 by mechanised trawlers at Tuticorin.

Months	Effort (units)	Rock cods	Snappers	Threadfins	Pig face breams	Others	Total	CPUE (kg)
April	—	—	—	—	—	—	—	—
May	—	—	—	—	—	—	—	—
June	4169	—	—	24.9	—	64.2	89.1	21.4
July	3531	—	—	65.4	1.2	65.1	131.7	37.3
August	3767	10.0	5.1	245.4	13.0	137.9	411.4	109.2
Sept.	3000	—	—	177.0	—	33.3	210.3	70.1
Oct.	3417	15.6	1.8	69.5	20.5	25.6	132.8	38.9
Nov.	2080	1.6	0.8	31.3	2.5	8.1	44.3	21.3
Dec.	2520	9.6	1.9	39.2	0.9	58.5	110.1	43.7
Jan.	3594	8.9	0.8	24.4	2.0	35.1	71.2	19.8
Feb.	1712	6.1	—	66.0	1.5	26.5	100.1	58.5
Mar.	1812	8.4	—	20.2	14.9	24.6	68.1	37.6
Total	29602	60.2	10.4	763.3	56.3	478.9	1369.1	46.3
%		4.4	0.7	55.8	4.1	35.0	—	—

TABLE 3.

Perch landings (in tonnes) during 1985 - '86 by mechanised trawlers at Tuticorin.

Months	Effort (units)	Rock cods	Snappers	Thread fins	Pig face breams	Others	Total	CPUE (kg)
April	2350	5.3	—	47.4	33.7	40.3	126.7	53.9
May	2773	2.1	—	23.2	37.6	55.1	118.0	42.6
June	4120	30.3	—	146.1	20.7	114.8	311.9	75.7
July	4088	37.5	—	55.4	44.5	30.4	167.8	41.1
Aug.	4075	40.1	29.7	268.4	82.5	131.3	552.0	135.5
Sep.	3672	74.3	—	200.9	142.0	105.9	523.1	142.5
Oct.	4260	87.2	0.5	262.5	112.2	180.5	642.9	150.9
Nov.	3600	26.1	8.4	132.7	50.6	60.5	278.3	77.3
Dec.	2120	8.7	1.5	12.7	30.2	29.2	82.3	38.8
Jan.	1792	19.4	8.0	6.4	55.0	55.4	144.2	80.5
Feb.	1848	122.3	57.3	8.8	124.0	57.7	370.3	200.4
Mar.	3775	77.3	18.4	95.7	130.6	90.4	412.4	109.3
Total	38473	530.6	124.0	1260.2	863.6	951.5	3729.9	97.0
%	—	14.2	3.3	33.8	23.2	25.5	—	—

TABLE - 4.

Perch landings (in tonnes) during 1986-'87 by mechanised trawlers at Tuticorin.

Months	Effort (units)	Rock cods	Snapp- ers	Thread- fins	Pig face breams	Others	Total	CPUE (kg)
April	4450	66.8	27.4	90.7	64.1	155.0	403.7	90.7
May	4238	81.5	26.8	79.1	148.1	175.8	513.3	121.1
June	4416	87.3	136.2	105.6	206.4	277.2	812.7	184.0
July	3838	21.2	5.5	142.4	30.4	144.5	344.0	89.6
August	5100	6.4	1.7	188.6	9.8	68.7	275.2	54.0
September	4163	81.2	81.2	64.2	48.3	226.6	503.3	121.0
October	2275	7.0	1.6	36.4	6.8	54.5	106.3	46.7
November	4608	52.2	74.5	20.9	94.0	137.1	378.7	82.2
December	3725	44.7	46.3	100.3	79.1	304.0	574.4	154.2
January	4025	48.1	27.8	34.1	57.4	161.1	328.5	81.6
February	3853	81.5	38.8	77.0	131.6	262.4	591.3	153.5
March	3940	72.0	41.5	120.7	147.2	375.4	756.8	192.1
Total	48631	651.9	509.3	1059.7	1023.2	2344.3	6588.4	114.9
%	—	11.7	9.1	19.0	18.3	41.9	—	—

3,562.5 t of perches were landed by 38,902 units of trawlers at the catch rate of 91.6 kg. The catch rate increased from 46.3 kg in 1986-87. The trawl net catches of perches were constituted by almost all the families. The annual average percentage composition was rock cods 11.6%, snappers 6.1%, threadfin breams 28.8%, pig face breams 18.2% and others 35.3%. *Scopopsis*, *Pomadasys*, *Therapon* and *Sillago* constituted the major portion of the other perches.

An estimated annual average catch of 114.8 t of perches were landed by 9,660 units of hooks and lines at the catch rate of 11.9 kg per unit. In a year on an average 73.8 t of perches were landed by 3368 units of *paruvai* (drift gill net - mesh size 120-170 mm) at the catch rate of 21.9 kg and 19.96 t by 1162 t units of *podivai* (mesh size 70-100 mm) at the catch rate of 17.2 kg. Trawlers contributed 94.5% of the total perches

landed at Tuticorin and the rest by hooks and line and drift gill nets.

The monthwise catch composition of perches landed by pair trawl operations during 1986-87 is given in Table 5. An estimated 1,613.4 t of perches were landed by 3828 units (pairs) at the catch rate of 421.5 kg. Pig face breams constituted 54.5% followed by rock cods (20.2%), other perches (15.0%) and snappers (10%). Threadfin breams constituted more 0.3% of the total perch catch by pair trawlers (Table 5).

POPULATION PARAMETERS

LETHRINUS NEBULOSUS

Length-weight relationship: The log values of total length in mm and weight in g of *Lethrinus nebulosus* were regressed to obtain the length weight relationship and it is expressed as $\text{Log } W = -1.6846 + 2.9551 \text{ Log } L$.

TABLE - 5.

Parch landings (in tonnes) during 1986-87 by mechanised pair trawlers at Tuticorin.

Months	Effort (units)	Rock cods	Snap- pers	Thread fins	Pig face breams	Others	Total	CPUE (kg)
April	250	12.5	1.4	0.2	31.9	17.5	63.5	251.0
May	234	9.5	1.7	0.7	30.6	9.1	51.6	220.5
June	212	14.5	2.1	0.4	54.9	27.1	99.0	467.0
July	182	9.0	0.7	0.3	18.5	10.9	39.4	216.5
August	312	9.8	1.1	0.5	30.0	10.1	51.5	165.1
September	338	44.5	20.1	0.2	44.9	67.1	176.8	523.1
October	480	48.5	15.7	0.3	98.9	27.8	191.2	398.3
November	625	57.3	90.6	0.6	123.3	24.6	296.4	474.2
December	348	42.3	21.4	0.2	140.2	12.7	216.8	623.0
January	278	37.5	2.4	0.5	127.4	15.5	183.3	659.4
February	324	25.4	1.9	—	92.7	10.8	130.8	403.7
March	245	15.7	2.0	0.7	85.2	9.5	113.1	461.6
Total	3828	326.5	161.1	4.6	878.5	242.7	1613.4	421.5
%	—	20.2	10.0	0.3	54.5	15.0	—	—

Growth: The growth of *L. nebulosus* has been estimated from the pooled data of weighted length frequency obtained during the years 3 from 1982-83 to 1984-85 at Tuticorin. The integrated method (Pauly, 1980) of tracing model progression in accordance to time was used in which different modes available in a month's length frequency were plotted against respective months as shown in Fig. 1. These

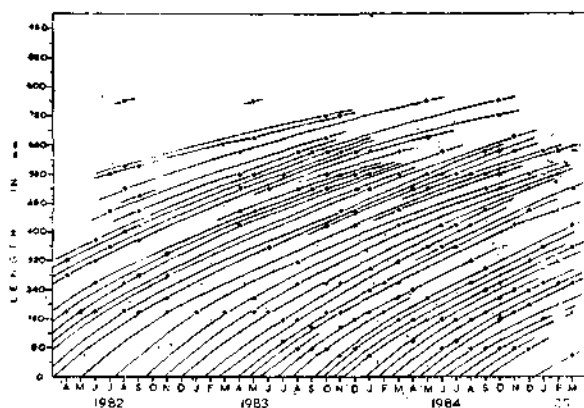

Fig. 1. Plots of modes in the length frequency against respective months and tracing of the progression of the modes to subsequent months for *Lethrinus nebulosus* from Tuticorin.

data were further plotted against respective months on an arithmetic graph and a curve was fitted through the plots and this curve may be expected to be the growth curve of this species (Fig. 2) and it can be seen from

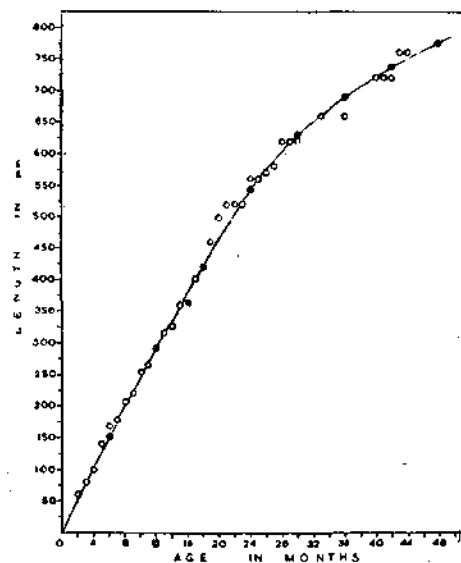

Fig. 2. Fitting a growth curve through the plots of average lengths attained by *Lethrinus nebulosus* in consecutive months obtained from the analysis shown in Table 10.

this curve that this species attains on an average 152, 292, 422.5, 546, 628.5, 689, 737 and 775 mm in 0.5, 1.0, 1.5, 2.0, 2.5, 3.0, and 4.0 years. These data were subjected to further analysis as per Bagenal method (Bagenal, 1955) and the growth in length (mm) of this species may be expressed as per Von Bertalanffy growth equation $L_t = 968 (1 - e^{-0.4172(t-0.0718)})$. As per the length weight relationship the growth in weight of this species is also computed by Bagenal method and this may be expressed as:

$$W_t = 23.4581 (1 - e^{-0.4900(t-0.0521)})^3.$$

Mortality rates: The natural mortality coefficient (M) is estimated from the life span of this species i.e., $T_{max} = 3 = 7.19$ years and $M = \frac{1}{(7.19-1)}$

$\times \ln \frac{100}{1} = 0.74$ and the independent estimate of M as per Pauly (1980) method is 0.73. The M is taken as 0.74 for this study. The total mortality coefficient (Z) is estimated as per Beverton and Holt (1956) method based on the equation $Z = K \frac{(L_{\infty} - L)}{L - L_c}$ where in L is the annual

average size, L_c is the size at first capture, L_{∞} asymptotic length and K growth constant. The Z was higher in podivalai and olaivalai, moderate in hooks and line, low in paruvai and trawl net and the average Z for this species in Tuticorin waters is 3.94 (Table 6).

Yield per recruitment: The yield per recruitment of this species for the age at first capture 0.6456 years at different fishing mortality coefficients and M/K ratios 1.0, 1.5, 2.0, 2.5 and 3.0 are shown in Fig. 3. For the prevailing M/K ratio 1.5 and age at first capture, the maximum fishing mortality coefficient which can bring the maximum yield of 666 g is 0.75 [Fig. 3]. Beyond this fishing mortality rate the yield per recruit declines from the maximum level. Higher the M/K ratio and lower the yield per recruit and the F_{max} increases in accordance with M/K ratio [Fig. 3].

The yield isopleth diagram drawn from the yield per recruitment obtained at varying age at first capture and fishing mortality coefficients for the M/K ratio 1.5 is shown in Fig. 4. The line A-A and B-B represent the eumetric fishing

TABLE 6
Estimates of total mortality coefficient (Z) obtained as per Beverton and Holt (1956) method for different gears for *Lethrinus nebulosus* from the length frequency data collected at Tuticorin.

Gear	Year	L. (mm)	Lc (mm)	Lr (mm)	Z	F
Podivalai	1982-83	210.1	158.0	148.0	6.07	5.33
	1983-84	180.7	148.0	136.0	10.05	9.31
	1984-85	178.4	138.0	130.0	8.15	7.41
Paruvai	1983-84	533.2	440.0	395.0	1.95	1.21
	1984-85	525.0	445.0	402.0	2.31	1.57
Hooks & Line	1983-84	480.5	435.0	310.0	4.37	3.73
	1984-85	482.0	438.0	315.0	4.61	3.87
Olaivalai	1982-83	97.5	50.0	46.0	7.65	6.91
	1983-84	127.0	55.0	43.0	4.87	4.13
Trawl net	1985-86	375.75	196.0	158.0	1.38	0.64
Average		319.0	250.3	208.3	3.94	3.20

$$t_c = 0.6456 \text{ Yrs. } t_r = 0.5092 \text{ Yrs.}$$

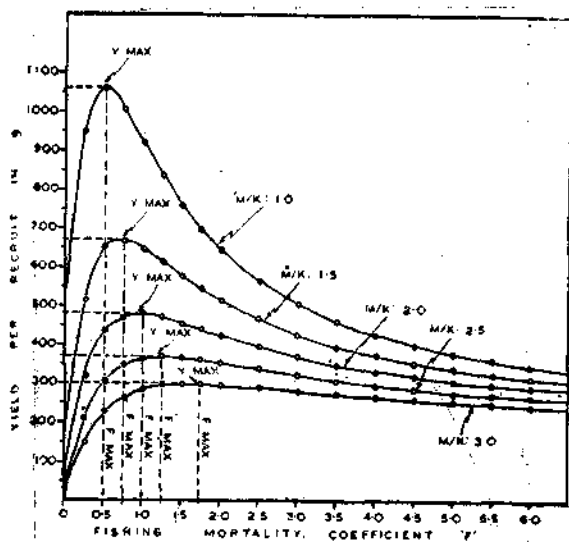

Fig. 3. Yield per recruitment of *Lethrinus nebulosus* for the prevailing age at first capture (0.6456 Yrs) at different M/K ratios and various fishing mortality coefficients and the yield max and F max are indicated for each M/K ratio.

curve and maximum sustainable yield curve respectively. The yield per recruit is directly proportionate to the increase in age at first capture and fishing mortality rate upto a certain level, beyond which the yield does not increase and it is not commensurate with the effort input. Hence, further increase in effort beyond this level may become uneconomical. In podivalai the average size at first capture is 148 mm

which can yield 580 g at the F max of 0.5. Whereas the F during 1982-85 was on an average nearly 15 times higher and the same condition prevailed in respect of olivalai and hooks and line with little variation in F. However, in parupalai and trawl net the effort expended just coincided with F max which could bring in the yield max for the respective age at first capture.

Optimum age of exploitation and potential yield per recruit:

The optimum age of exploitation [ty] is defined as the age when the brood attains its maximum weight and the potential yield [Y] is the quantity corresponding to this weight as a function of infinite fishing intensity [Beverton and Holt, 1967]. The optimum age or exploitation is estimated to be 2.15 years when it attains a size of 561 mm and the potential yield per recruit estimated by the method of Krishnan Kutty and Qasim [1968] is 1340 g which is indicated in the yield isopleth diagram.

NEMIPTERUS JAPONICUS

Growth: The growth of *N. japonicus* was estimated to be

	1964-65	1965-66	1966-67
L_{∞}	305.43 mm	208.7 mm	302.63 mm
K	0.3141	0.648	0.2941

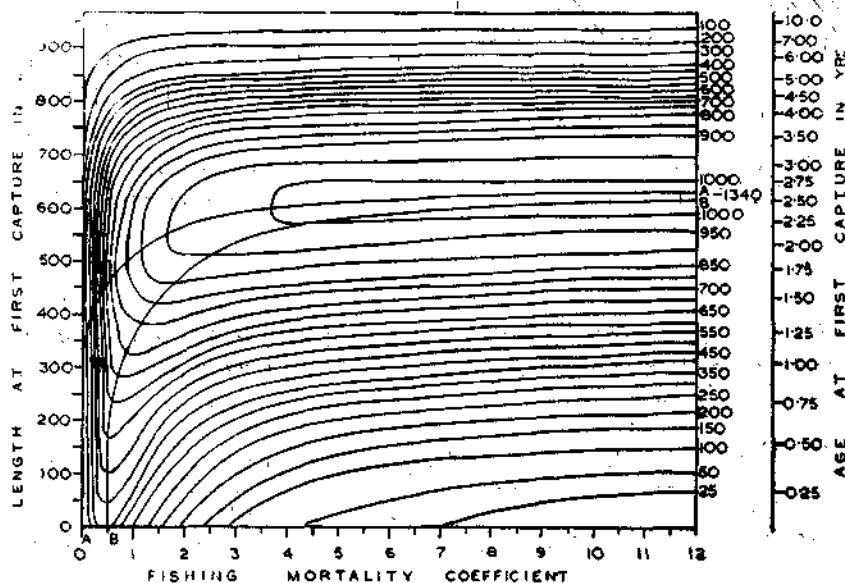

Fig. 4. Isopleth diagram for yield per recruit in gram of *Lethrinus nebulosus* population in Tuticorin waters, Gulf of Mannar. The eumetric fishing curve (line AA), maximum sustainable yield curve (line BB) and potential yield per recruit of 1340 g are also shown.

by Krishnamoorthi [1971] from the data collected from landing of Government of India vessels [trawlers] operated along Andhra-Orissa coast. The same data were subjected to the integrated modal progression analysis as already explained [Pauly, 1980] and the tracing of modes are shown in Fig. 5. The average lengths are shown in Fig. 6 wherein the empirical growth curve of this species is fitted through the plots. From this curve it is estimated that this species attains a length of 102, 150, 183, 211, 235.5, 255, 271.5 and 284.5 mm in 0.25, 0.50, 0.75, 1.08, 1.25, 1.50, 1.75 and 2.00 years and based on these data growth parameter, L & K and t_0 were estimated as per Bagenal [1955] method. The growth in length [mm] of this species may be expressed as non Bertalanffy growth equation $L_t = 336 [1 - e^{-0.8808(t+0.0411)}]$. The growth in weight based on the length weight relationship $\text{Log } W = -3.7432 + 2.5239 \text{ Log } L$,

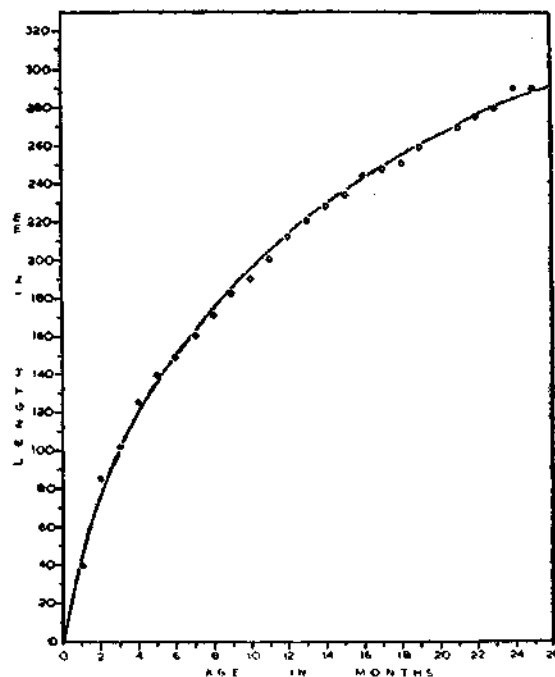

Fig. 6 Fitting of growth curve through the plots of average lengths attained by *Nemipterus japonicus* in consecutive months obtained from the analysis shown in Table 12.

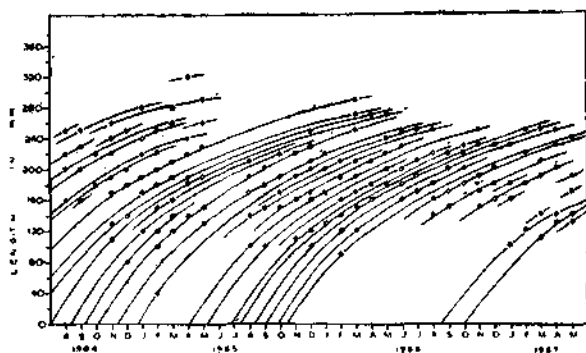

Fig. 5. Plots of modes in the length frequency against respective months and tracing of the progression of modes in subsequent months for *Nemipterus japonicus* from Andhra and Orissa coast.

may be expressed as $W_t = 7.3889 [1 - e^{-0.9689(t+0.0679)}]^3$.

Mortality rates: The natural mortality coefficient [M] is estimated to be 1.85 from T_{max} of this species and the independent estimate of M as per Pauly [1980] is 1.6. The M is taken as 1.85 for this species in this study. The total mortality coefficient [Z] estimated according to Beverton and Holt [1956] method are shown in Table 7. The Z increased from 2.91 in 1964-65 to 3.03 in 1965-66 and to 3.83 in 1966-67. The gear selection factor estimated from the left

TABLE - 7.
Estimates of total mortality coefficient (Z) obtained as per Beverton and Holt (1956) method for *Nemipterus japonicus* during 1964-67 from the length frequency data collected at Visakhapatnam.

Gear	Year	L (mm)	Lc (mm)	Lr (mm)	Z	F
Trawlnet	1964-65	199.7	156.0	142.0	2.91	1.06
	1965-66	180.2	136.0	116.0	3.03	1.18
	1966.67	189.0	156.0	144.0	3.83	1.98
	Average	189.6	149.3	134.0	3.13	1.28

side of the catch curve [Pauly, 1984] was used to obtain the age of first capture [t] and the age at recruitment [tr].

Yield per recruit: The yield per recruitment of this species for different fishing mortality coefficient [F] for the prevailing age at first capture 0.6815 years for 3 different M/K ratios

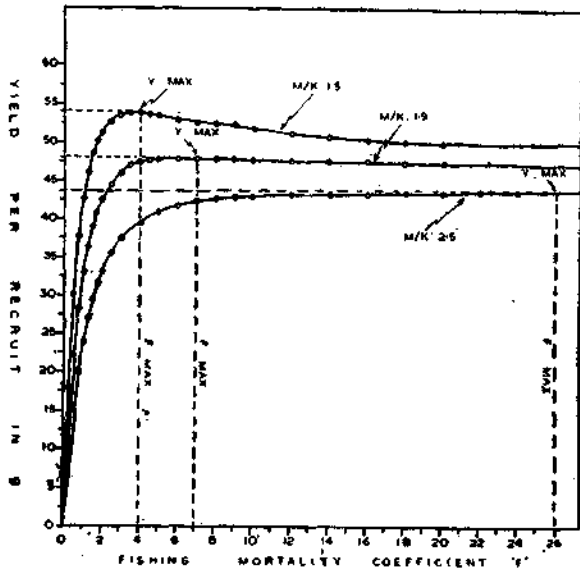

Fig. 7 Yield per recruit of *Nemipterus japonicus* for the age at first capture (0.6815 year) at different M/K ratios and various fishing mortality coefficient and the yield max and F max are indicated for each M/K ratio.

are given in Fig. 7. For the prevailing age at first capture and M/K ratio of 1.9, the fishing intensity which can bring in the highest yield is 7.0 and the yield is 48.2 g. Higher the M/K ratio, lower the yield per recruit and higher the F max, (Fig. 7). The yield isopleth diagram drawn from the yield per recruitment obtained at varying age at first capture and fishing mortality coefficients for M/K ratio 1.9 is shown in Fig. 8. The eumetric fishing [line A-A] and maximum sustainable yield curve [line B-B] are indicated in the figure. The yield isopleth diagram clearly indicates that the then prevailing age at first capture 0.6815 year is sufficiently high enough to permit further increase in effort. The yield also increases with the F upto 7 and commensurates with the effort input [Fig 8].

Optimum age of exploitation and potential yield per recruit:

The optimum age of exploitation for this species is estimated to be 0.86 years when it attains a length of 186 mm and the potential yield is 55 g which is indicated in the yield isopleth diagram (Fig. 8).

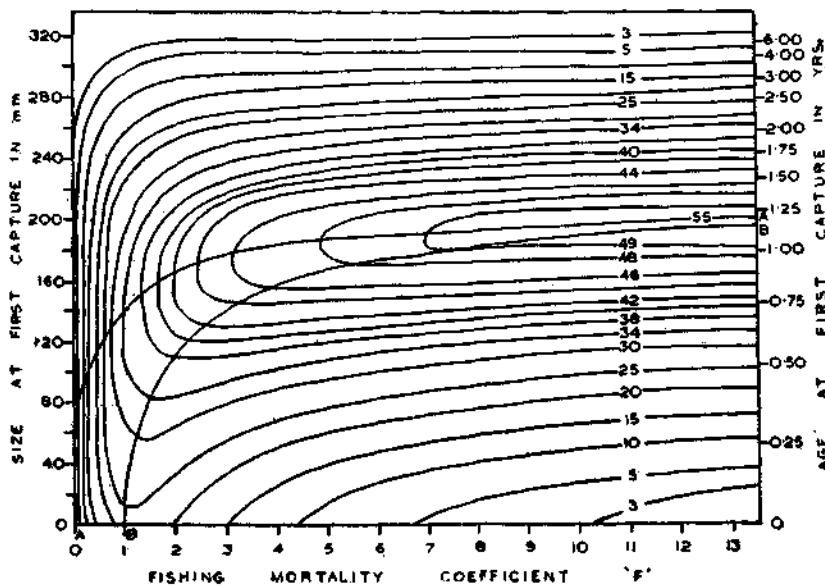

Fig. 8. Isoleth diagram for yield per recruit in gram of *Nemipterus japonicus* population in Andhra and Orissa coast. The eumetric fishing curve (line AA),- maximum sustainable yield curve (line BB) and potential yield per recruit of 55 g are also shown.

DISCUSSION

The annual perch production of India has increased three fold compared to the landings in 1969. This is mainly due to mechanisation of the fishing fleet and introduction of small scale mechanised trawlers in India. As seen from the perch catch by different gears, the trawlers have landed the major portion of the catches and threadfin breams were the dominant group. Mechanised fishing over the two decades has changed not only the fishing pattern but the constituent fisheries also. The introduction of high opening bottom trawl for pair trawling operations by gear technologists of the EAO project on development of small scale fisheries under Bay of Bengal programme (BOBH) founded by Swedish International Development Authority [SIDA] has generated great interest among the boat owners resulting in intense fishing effort by pair trawling which yield not only higher catch than the conventional trawler but also fishes of large sizes. The perches landed by these units at Tuticorin are always large in size and four times higher in quantity than the other conventional units as the pair trawl units could venture into deeper waters and could sweep wider area also. Further expansion of this type of fishing operation and increase in the fishing effort along the west and east coast of India is expected to increase not only the general fish production but perch production also considerably.

Considering the individual species, the yield per recruitment shown in yield isopleth diagram for *L. nebulosus* [Fig. 4] indicate that this species presently faces higher fishing pressure by gears like podivalai, olaivalai and hooks and line as the prevailing fishing mortality rates are higher than the 'F max' which can bring in the highest yield. As the gears presently employed do not aim at exploiting particularly this species and this study confines only to Tuticorin waters, it is difficult to advocate any regulatory measure at this stage. The study on the population dynamics of *N. japonicus* reveal that the age at first capture [0.6815 year] is sufficiently high enough as it is close to the optimum age of exploitation [0.86 years] and there is scope for increase in the fishing effort as the fishing mortality rate

can be as high as 7. Such studies on other component species of threadfin breams are most essential for proper fishery management of the perch resources as the threadfin breams constitute the major portion of the perch catch by trawlers in India.

Nearly a decade ago Jones and Banerji [1973] expressed the scope for the increase in perch production in view of the potential yield from the Indian waters. James *et al* [1986] have mentioned the potential yield of various commercially important species revealing the prospects for increased production in the country. The survey by the Integrated Fisheries Project has revealed apart from the major resources, several potential nonconventional resources like the big eye, *Priacanthus* spp., the Indian drift fish *Psenes indicus* and *Centrolophus niger*. Modernization of small country craft is a good sign of progress in the fishing industry. Diversified fishing operations in relatively deeper waters is also advocated to get increased yield.

REFERENCES

- ANON. 1981. All India census of marine fishermen, craft and gear. *Mar. Fish. Infor. Serv. T & E Ser.*, 30 : 1-32.
- ANON. 1983. Trends in marine fish production in India. *Mar. Fish. Infor. Serv. T & E Ser.*, 52 : 1-21.
- ANON. 1986. Marine fish production in India during 1983-'84 and 1984-'85. *Mar. Fish. Infor. Serv. T & E Ser.*, 67 : 1-79.
- BAGENAL, T. B. 1955. The growth rate of the long rough dab *Hippoglossoides platessoides* (Fabr). *J. Mar. Biol. Ass. U. K.*, 34: 297-311.
- BEVERTON, R. J. H. AND S. J. HOLT. 1956. A review of the methods for estimating mortality ratio in exploited fish populations with special reference to sources of bias in catch sampling. *Repp. Cons. Explor. Mer.*, 140 (1) : 67-83.
- BEVERTON, R. J. H. AND S. J. HOLT. 1957. On the dynamics of exploited fish populations. *Fishery Investigations*

Ministry of Agriculture, Fisheries and Food, London), Series 2, 19 : 533 pp.

- JAMES, P. S. B., R., K. ALAGARSWAMI, K. V. NARAYANA RAO, M. S. MUTHU, M. S. RAJAGOPALAN, K. ALAGARAJA AND C. MUKUNDAN. 1986. Potential Marine Fishery Resources of India. *Seminar on potential marine fishery resources*, CMFRI, Cochin.
- JONES, S. AND S. K. BANERJI 1973. A review of the living resources of the Central Indian Ocean. *Proc. Symp. Living Resources*, India, pp. 1-17.
- KRISHNAMOORTHY, B. 1971. Biology of the threadfin bream *Nemipterus japonicus* [Bloch]. *Indian J. Fish.*, 18 (1 & 2): 1-21.
- KRISHNAN KUTTY, M. AND S. Z. QASIM. 1968. The estimation of optimum age of exploitation and potential yield in fish populations. *J. Cons. perm. int. Explor. Mer*, 32 [2] : 249-255.
- PAULY, D. 1980. A selection of simple methods for the assessment of tropical fish stocks. *FAO Fisheries Circular*. 729, FIRM/129, pp. 54.
- PAULY, D. 1984. Length converted catch curves: A powerful tool for fisheries research in the tropics [Part II], *Fishbyte*, 2 [2] : 17-19.
- RAO, K. V. 1973. Distribution pattern of the major exploited marine fishery resources of India. *Proc. Symp Living Resources*, India, pp. 18-101.
- RICKER, W E. 1958. Handbook of computations for biological statistics of fish population. *Bull. Fish. Bd. Canada*, 119, 300 pp.
- SEKHARAN, K. V. 1974. Estimates of stocks of oilsardine and mackerel in the present fishing grounds off the west coast of India *Indian J. Fish.* 21 [1] : 177-182.
- SNEDECOR, G. W AND W. G. COCHRAN 1967. *Statistical methods*. 6th edn. Oxford and IBH publishing Co., New Delhi.

POPULATION DYNAMICS OF OTOLITHES CUVIERI (TREWAVAS) OFF BOMBAY WATERS

Sushant K. Chakraborty

Bombay Research Centre of Central Marine Fisheries Research Institute,
Army & Navy Bldg., 2nd Flr., 148, M. G. Road, Bombay-400 001.

ABSTRACT

Studies on the age and growth and population dynamics of *Otolithes cuvieri* (Trewavas) based on the data collected for a period of six years from 1979-80 to 1984-85 off Bombay waters are reported here. This species attains 170 mm, 260 mm and 318 mm at the end of first, second and third years of its life respectively. The von Bertalanffy's growth parameters estimated were as follows: $L_{\infty} = 395$ mm, $K = 0.5331$ (annual), $t_0 = 0.06246$ years. Using the length-weight relationship formula $W = aL^b$ was calculated as 615 gms. Instantaneous rates of total, natural and fishing mortality were estimated as $Z = 2.64$, $M = 1.30$ and $F = 1.34$. Exploitation ratio (E) and the exploitation rate (U) were found to be 0.50 and 0.47 respectively.

The annual average yield at the present rate of exploitation is 763.815 tonnes as compared to the total stock of 1619.66 tonnes and standing stock of 570.264 tonnes. The MSY was estimated as 788.13 tonnes. The investigation undertaken indicates that the stock of *O. cuvieri* is optimally exploited. Thus any further increase in the efforts would be detrimental to the fishery of this species.

INTRODUCTION

Sciaenids are the chief constituents of the trawl catch at Bombay contributing about 7% of the total trawl catch. Though it is a multispecies fishery, *O. cuvieri* contributes about 35% of the total sciaenids. Estimation of age and growth of Indian Sciaenids have been done on *Pseudosciaena diacanthus* by Rao [1961, 1971a and 1971b] and Rao [1971], *Otolithus brunneus* by Kutty [1961] and Jayaprakash [1978] and *Johnnieops vogleri* by Muthiah [1982] from the west coast of India and on *Pseudosciaena coibor* by Rajan [1964] and *Johnius (Johnius) carutta* by Murty [1986] from the east coast of India.

The present investigation deals with the estimation of von Bertalanffy's growth parameters, mortality, and yield per recruit of *Otolithes cuvieri* based on the data collected from the year 1979-80 to 1984-85 at New Ferry Wharf Jetty, one of the major landing centres of Greater Bombay.

MATERIAL AND METHODS

Catch and effort data of commercial trawlers were collected from New Ferry Wharf

landing centre of Greater Bombay by the field staff. Weekly observation was taken for length and species composition. The estimated numbers in each length group were raised to day's catch and subsequently to month's catch. Length data were grouped into 5 mm class intervals for growth study. Scatter diagram technique of Devaraj [1902a] has been employed for the present study. The modal lengths in the frequency data were first plotted in the form of a scatter diagram against the co-ordinates of length starting from zero upwards on the ordinates and the time in months on the abscissa. The trend of progression of modes through time was then indicated by the eye fitted line. The fitted line was extrapolated free-hand with reference to the intermodal slopes so as to intersect it on the time axis indicating thus the time of brood origin, the number of broods per year class and also the growth of each brood. Growth was expressed by employing von Bertalanffy's [1938] growth equation.

$$L_t = L_{\infty} [1 - e^{-k(t-t_0)}]$$

L_{∞} and K were estimated by using Ford-Walford plot of L_{t+1} against L_t given by

$$L_{t+1} = L_{\infty} [1 - e^{-k}] + e^{-k} L_t$$

and t_0 was calculated by using the following expression

$$-\text{Loge} \left[\frac{L_{\infty} - L_t}{L_{\infty}} \right] = -Kt_0 + kt$$

Length-weight relationship was fitted using the well known formula-

$$W = a.L^b \text{ or } \text{Log } w = \text{Log } a + b [\text{Log } L]$$

Instantaneous rate of total mortality [Z] was estimated by [a] Length converted catch curve method of Pauly [1982] by using the relation-

$$\text{Log } e[N/\Delta t] = a + b.t$$

where Δt is the time taken to grow from lower limit to upper limit in each length class, 'N' is the numbers caught in each length group, 'a' is the y-axis intercept and 'b' = Z with the sign changed and 't' is the mid-point in each length group. Here only the descending right limb is taken for the estimation of 'Z'.

[b] Alagaraja's [1984] method by the equation given as-

$$\log [N_t + \Delta t/N_t] = \frac{Z}{K} = \log e \left\{ \frac{L_{\infty} - L_t + \Delta t}{L_{\infty} - L_t} \right\}$$

Where L_t and $L_t + \Delta t$ are successive mid values of each length class whose frequencies are N_t and $N_t + \Delta t$. It was considered that 'Z' is constant for the entire size range of the catches in numbers at successive age, C_t and $C_t + \Delta t$ are proportional to N_t and $N_t + \Delta t$.

[c] Beverton and Holt's [1956] formula

$$\frac{Z}{K} = \frac{[L_{\infty} - \bar{L}]}{\bar{L} - L_c}$$

Where L_{∞} and K are the parameters of von Bertalanffy's growth equation, \bar{L} is the mean length in the range L_c to L_{∞} . Natural mortality coefficient 'M' was estimated by Cushing's [1968] formula using the expression

$$Z = M = \frac{1}{t_{\max} - t} = \text{Log } e \frac{N_0}{N_t \max.}$$

Where N_t is the number of one year old fishes and $N_{t \max}$ the numbers at maximum age in a

fish population. The second method employed for the estimation of 'M' was that of Pauly [1980 b] given as-

$$\text{Log}_{10} M = 0.0066 - 0.279 \text{Log}_{10} L_{\infty} + 0.6543 \text{Log}_{10} K + 0.4634 \text{Log}_{10} T$$

where L_{∞} is in cm, K is annual and T is in temperature in °C. Here T of 28.2°C was taken from Bapat *et al.* [1982]. The rate of exploitation [U] and the exploitation ratio [E] for different years were estimated.

The yield in weight per recruit was estimated by using dynamic pool model of Beverton and Holt [1967].

Maximum sustainable yield [MSY] was calculated by using Corten's [1974] method given as

$$Y_1 = \frac{X_2 - Y_1}{X_1}$$

where X_1 is the Yw/R in gm at present value of F and Y_1 is the corresponding yield in tonnes and X_2 is the Yw/R in gm at F_{\max} .

MSY was also estimated by using Gulland's [1979] formula given as

$$Py = Zt \times 0.5 \times Bt \text{ in the usual notation.}$$

Potential yield per recruit and optimum age of exploitation was estimated by the equation developed by Krishnan Kutty and Qasim [1968].

RESULTS

Age and Growth: This is based on the data collected for a period of five years from 1980-81 to 1984-85 at New Ferry Wharf landing centre. Since smaller fishes were not represented in the trawl catch samples were also collected from 'dol' netters from 1981-83 in order to supplement the data [Fig. 1]. The smallest fish obtained from trawl and dol net were 95 mm and 26 mm respectively. The K, L_{∞} and t_0 were estimated as 0.5331 [annual], 395 mm and - 0.06246 years. Plotting of $L_t + 1$ against L_t Ford [1933] and Walford [1946] gave a linear relationship [Fig.2]. This fish attains 170 mm, 260 mm and 318 mm at the end of its first, second and third year of its life. The actual

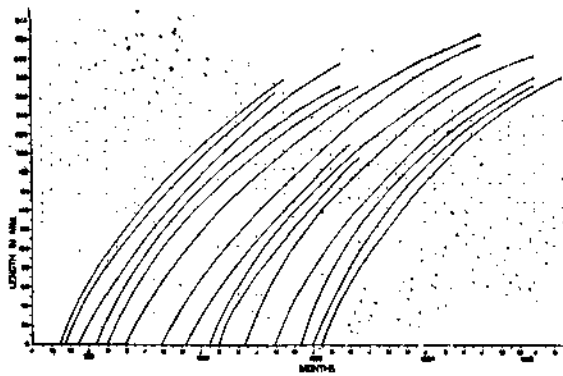

Fig: 1 Scatter diagram of modal length for *O. cuvieri*

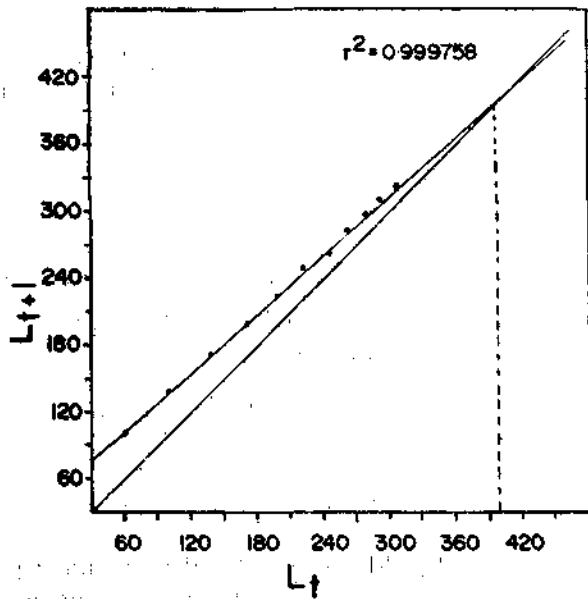

Fig: 2 Ford-Walford plot of L_t against L_{t+1}

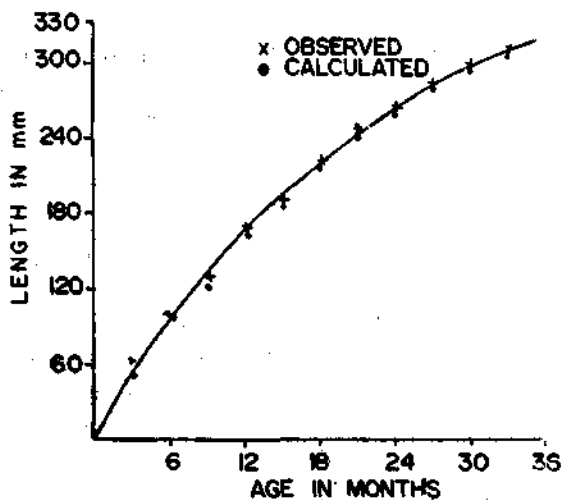

Fig: 3 Calculated and observed length at age t

growth obtained by modal progression and the calculated growth obtained by VBGF is given in Fig. 3.

Length-weight relationship: Individual length and weight of 336 males 326 females were analysed separately for both the sexes. The formula obtained thus is-

$$\text{Males Log } W = -5.237499 + 3.0831 \text{ Log } L$$

$$\text{Females Log } W = -4.7195719 + 3.0341 \text{ Log } L$$

The differences between the regression coefficients of sexes were tested for its significance by analysis of covariance following Snedecor and Cochran [1967]. The difference was found to be not significant at 5% level. Hence the data of both the sexes were pooled together and a common formula was obtained for the calculation of W_{∞} .

$$\text{Log } W_{\infty} = 5.3311 \times L_{\infty} \times 3.127248$$

giving W_{∞} of 615 gms.

$$[r^2 = 0.966 \text{ and } S. E. = 0.0623]$$

Mortality Estimates: Estimation of total mortality coefficient [Z] by three methods and their average is given in table 1. The Z estimated by length converted catch curve [Fig. 4] and Beverton and Holt's methods was slightly higher as compared to Alagaraja's method. Average estimate of $Z = 2.64$ obtained by these three methods was taken into consideration for further calculations.

Fishing mortality coefficient was obtained by subtracting M from Z given as-

$$F = 2.64 - 1.30 = 1.34$$

Total stock and Standing stock: Year-wise annual yield in tonnes, F , M , Z , E , total stock (Y/U) and standing stock (Y/F) are given in table 2. The average yield during this period was 762.815 tonnes as compared to total and standing stocks of 1619.56 tonnes and 569.264 tonnes respectively.

Yield per recruit studies: By using the length-weight relationship W_{∞} of 615 gms was estimated at L_{∞} of 395 mm. The length of the smallest fish observed in the trawl catch was 95 mm and its age was estimated as 0.5 years. This was taken as age at first recruitment [tr]. Average of the annual length, length

TABLE 1

Estimation of Z by three methods and their averages

Year	Alagaraja's method	Length converted catch curve Method	Beverton and Holt's method	
1979-80	1.53	2.15	2.16	1.94
1980-81	1.20	3.17	2.25	2.20
1981-82	1.32	2.37	1.73	1.80
1982-83	2.71	3.22	3.15	3.02
1983-84	3.60	4.11	2.98	3.56
1984-85	2.59	3.11	4.26	3.32
	2.15	3.02	2.75	2.64

TABLE 2

Year-wise details of annual yield, fishing mortality, exploitation ratio, exploitation rate, total and standing stock

Year	Catch in tonnes	F	M	Z	E	U	Y/U	Y/F
1979-80	729.637	0.64	1.30	1.94	0.329	0.282	2587.365	1140.057
1980-81	1047.603	0.90	1.30	2.20	0.409	0.363	2885.958	1164.003
1981-82	709.718	0.50	1.30	1.80	0.277	0.231	3072.37	1419.436
1982-83	474.86	1.72	1.30	3.02	0.569	0.541	877.74	276.081
1983-84	870.403	2.26	1.30	3.56	0.634	0.161	1411.388	385.134
1984-85	744.665	2.02	1.30	3.32	0.608	0.638	1167.186	368.646
Average	762.815	1.34	1.30	2.64	0.507	0.471	1616.56	569.264

'E' and 'U' have been estimated from 'F' and 'Z' in average column.

TABLE 3

Estimation of MSY by Corten and Gulland's method

Year	Z	Yield in tonnes	MSY by Gulland's Method (in tonnes)	Yw/R at Present F	Yw/R at Fmax	MSY by Corten's Method (in tonnes)
1979-80	1.94	729.637	1105.856	17.9721	24.0832	976.6505
1980-81	2.20	1047.603	1280.403	21.2989	24.0832	1184.55
1981-82	1.80	709.718	1277.492	17.9821	24.0832	950.516
1982-83	3.02	474.86	416.882	23.9045	24.0831	478.405
1983-84	3.56	870.473	685.593	24.0415	24.0832	871.982
1984-85	3.32	744.665	0611.952	24.0618	24.0832	745.327
Average	2.64	762.815	*751.429	*23.3096	*24.0832	*788.131

Not averages

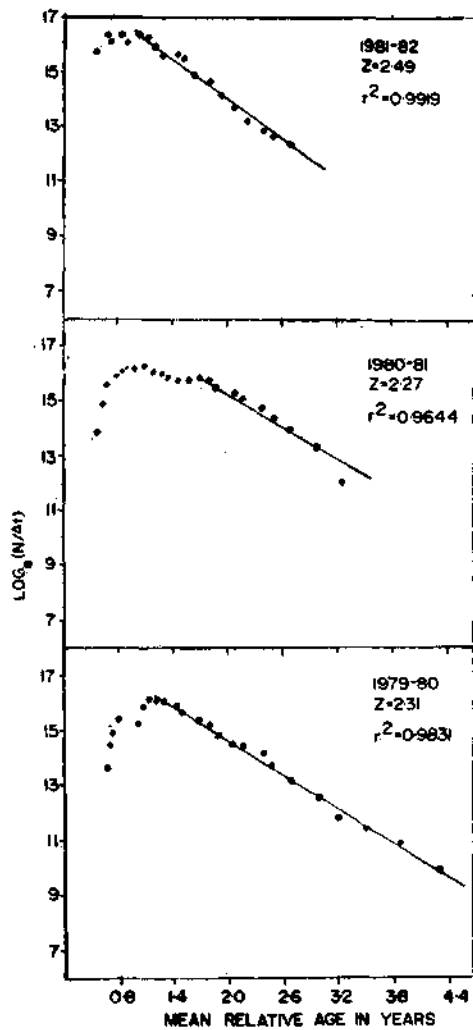

Fig: 4 Estimation of Z by length converted catch curve method

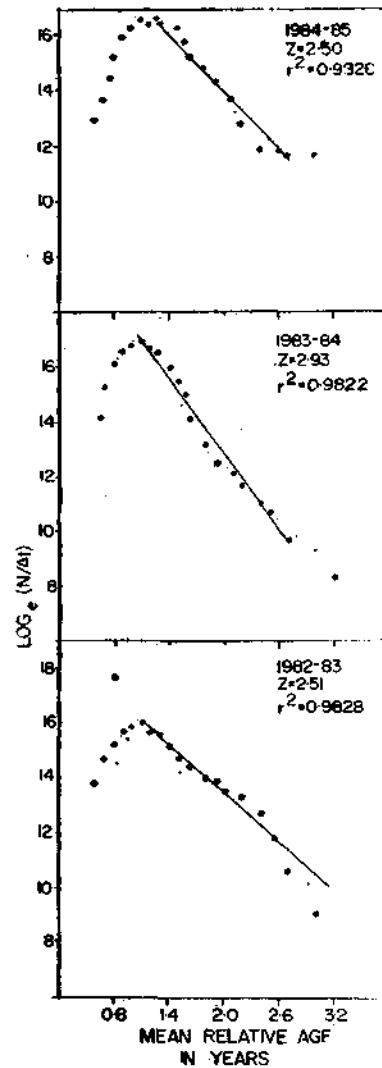

Fig 5 Yield curve of *O. cuvieri* at different values of F

frequency distribution of six year period showed the smallest mode at 149 mm. This was taken as the length at first capture [t_c] the corresponding age being 0.8 years.

The yield curve (Fig.5) shows that Y_w/R at the present F of 1.34 is 23.30944 gms as compared to Y_w/R of 24.0832 gms at F_{max} of 1.95 gms.

The yield isopleth diagram depicting the isolines of yield for varying levels of t_c on the y-axis and E on the x axis was prepared from the yield table [Fig 6]. Both eumetric fishing curve (BB') and MSY curve AA' converge at a point on the yield isopleth diagram vertically above F_{∞} giving potential yield per recruit of 27.4725 gms.

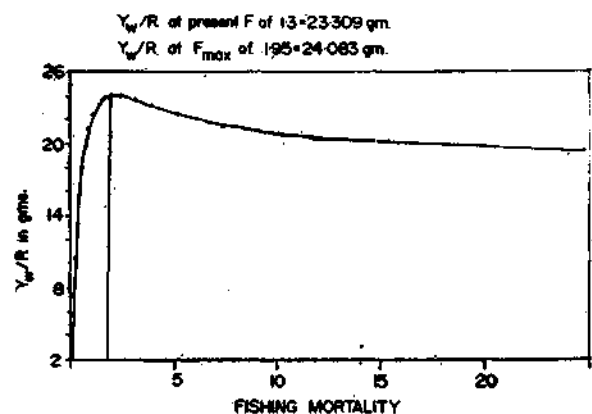

Fig: 6 Yield isopleth diagram of *O. cuvieri*

Following the formula developed by Kutty and Qasim [1968] the potential yield per recruit of 28.1384 gms was estimated at optimum age of exploitation of 1.4856 years.

Average MSY obtained for this six year period by Corten's [1974] and Gulland's (1979) method was 788.131 and 751.42 tonnes respectively.

DISCUSSION

Gulati [1987] estimated the first and second year growth of *O. cuvieri* as 183 mm and 282 mm respectively, which are higher, to those estimated in the present study. The growth parameters estimated by him were $L_{\infty} = 330.66$ mm, $K = 0.93034$ [annual] and $t_0 = -0.00269$ years. L_{∞} of 395 mm estimated in the present study is close to the largest size of 359 mm observed in nature.

'Z' estimated by Gulati for the year 1972-73 and 1983-84 by Jackson's method was 1.45 and 1.64 while the 'M' estimated by him was 1.45 and 1.64 respectively. In the present investigation 'M' of 1.30 and 1.1 was estimated by Cushing's and Pauly's method respectively.

Stock assessment studies undertaken by Gulati are based on the data of 1983-84 and the total and standing stock of 56,294 tonnes and 27,572 tonnes was estimated by him as compared to 1619.56 tonnes and 569.284 tonnes in the present investigation for a six year period from 1979-80 to 1984-85. The vast difference is due to the fact that Gulati has estimated the total and standing stock of whole of Maharashtra state based on his observation at New Ferry Wharf. Moreover, 'F' is 0.19 for the year 1983-84.

From the present study it is seen that the average annual yield of *O. cuvieri* during this period is 762.81 tonnes as compared to the total stock of 1619.56 tonnes and standing stock of 569.26 tonnes. The yield per recruit curve shows that Yw/R in gms is at 23.30944 gms at the present level of $F = 1.34$, $t_c = 0.8$ and E of 0.507. It can be increased to 24.0832 gms at $F = 1.95$ gms and $E = 0.60$. The catch may increase

beyond $E = 0.60$ with further increase in fishing efforts though the same may not be economical. Moreover, from the biological point of view it would be detrimental to the fishery leading to its virtual collapse.

Gulland [1971] has stated that optimum exploitation ratio [E] gives a rough idea if a stock is overfished or not on the assumption that the optimum value of E [E_{opt}] is about or equal to 0.5. The present E of *O. cuvieri* is 0.507 which indicates that the stock of this species is optimally exploited and any further increase in the fishing effort may be harmful for the general health of the stock.

It can thus be concluded that the stock of *O. cuvieri* is at present being optimally exploited and at the present E there is no threat for the depletion of stock.

ACKNOWLEDGEMENTS

The author wishes to express his sincere thanks to Shri B. B. Chavan for the help rendered in the field and laboratory.

REFERENCES

- ALAGARAJA, K. 1984. Simple methods for estimation of parameters for assessing exploited fish stocks. *Indian J. Fish.* 31 [2] : 177-208.
- BAPAT, S. V., V. M. DESHMUKH, B. KRISHNA-MOORTHY, C. MUTHIAH, P. V. KAGWADE, C. P. RAMAMIRTHAM, K. J. MATHEW, S. KRISHNA PILLAI AND C. MUKUNDAN, 1982. Fishery resources of the exclusive economic zone of north-west coast of India. *Bull. Cent. Mar. Fish. Res. Inst.* 33 : 85 p.
- BERTALANFFY, L. VON. 1939. A quantitative theory of organic growth. *Hum. Biol.* 10 : 181-213.
- BEVERTON, R. J. H. AND S. J. HOLT, 1956. A review of methods for estimating mortality rates of exploited fish populations with reference to source of bias in catch sampling. *Rapp. P. V. Reun. CIEM*, 140 : 67-83.

- BEVERTON, R. J. H. AND S. J. HOLT. 1957- On the dynamics of exploited fish populations. *Fish. Invest. Minist. Agri. Food G. B. (2 Sea Fish)*, 19 : 533 p.
- CORTEN, A. 1974. Recent changes in the stock of Celtic Sea herring (*Clupea herrungus* L.) *J. Cons. Perm. int. Explor. Mer.* 35 : 194-201.
- CUSHING, D. H. 1968. *Fisheries biology - A study of population dynamics*. Univ. Wisconsin Press, Madison, Wis. 200 p.
- DEVARAJ, M. 1982 a. Age and growth of three species of seer fishes *Scomberomorus commerson*, *S. guttatus* and *S. lineolatus*. *Indian J. Fish.*; 28 [1 and 2] 1981 : 104-127.
- FORD, E. 1933. An account of herring investigations conducted at Plymouth during the years 1924-1933. *J. Mar. Biol. Ass. U. K.* 19 : 305-384.
- GULLAND, J. A. 1971. *The fish resources of the oceans*. West Byfleet, Surrey News (Books), Ltd., for FAO 255 p.
- GULLAND, J. A. 1979. Report of the FAO/IOP workshop on the fishery resources of the Western Indian Ocean South of the Equator. *Rome, FAO, IOPC, DEV179/45*: 1-37.
- GULATI, DEEPAK, K. 1987. Morphometry, biology and stock assessment of *Otolithes cuvieri* [Trewavas, 1974] off Bombay coast. M. Sc. Thesis, University of Bombay.
- JAYAPRAKASH, A. A. 1978. Age and growth of juveniles of 'Koth' *Otolithoides brunneus* [Day] in the Bombay waters. *Indian J. Fish.* 23 : 86-96.
- KUTTY, M. K. AND S. Z. QASIM. 1968. The estimation of optimum age of exploitation and potential yield in fish populations. *J. Cons. perm. inst. Explor. Mer.*, 32 [2] : 249-255.
- KUTTY, M. N. 1961. Scales and Otoliths of 'Koth' *Otolithoides brunneus* as age indicator. *Indian J. Fish.*, 8 : 145-151.
- MURTY, V. SHRIRAMACHANDRA 1986. Growth and yield per recruit of *Johnius [Johnius] carutta* [Bloch] in the trawling grounds off Kakinada. *Indian J. Fish.*, 33 (2) : 163-170.
- MUTHIAH, C. 1982. Study on the biology of *Johnieops vogleri* [Bleeker] of Bombay waters. *Indian J. Fish.*, 29[1-2] : 118-133.
- PAULY, D. 1980 b On the linear relationship between natural mortality, growth parameters and mean environmental temperature of 175 fish stocks. *J. Cons. CIEM*, 39 [2] : 175-192.
- PAULY, D. 1982. Studying single species dynamics in tropical multispecies context pp 33-70. In Pauly, D. and G. I. Murphy [Eds.] *Theory and Management of tropical fisheries* ICLARM conference Proc. 9, 360 pp ICLARM, Manila, Philippines and CSIRO, Cronulla, Australia.
- RAJAN, S 1964. The biology and fishery of *Pseudosciaena coibor* [Hamilton] from Chilka lake. *Indian J. Fish.*, 11 [1] : 659-662.
- RAO, K. S. 1971. Studies on the scales of *Pseudosciaena diacanthus* [Lacepede] for estimating growth parameters. *Indian J. Fish.*, 15 : 127-144.
- RAO, K. V. S. 1961. Studies on the age determination of 'Ghol' *Pseudosciaena diacanthus* [Lacepede] by means of scales and Otoliths. *Indian J. Fish.*, 8 : 121-125.
- RAO, K. V. S 1971 a. Age and growth of 'Ghol' *Pseudosciaena diacanthus* Lacepede in Bombay and Saurashtra waters. *Indian J. Fish.*, 13 : 251-292.
- RAO, K. V. S. 1971. b- Estimates of mortality and yield per recruit of 'Ghol' *Pseudosciaena diacanthus* [Lacepede] *Indian J. Fish.*, 15 : 88-98.
- SNEDECOR, G. W. AND W.G. COCHRAN, 1967. *Statistical Methods*. Sixth Edition. Oxford and IBH Publishing Co., New Delhi, 533 p.
- WALFORD, L. A. 1946. A new graphic method of describing growth of animals. *Biol. Bull.* 90 [2] : 141-147.

OBSERVATIONS ON PELAGIC FISH EGGS AND LARVAE IN THE COASTAL WATERS OF TUTICORIN

Pon. Siraimetan and R. Marichamy

Central Marine Fisheries Research Institute, Cochin-682 031.

ABSTRACT

Quantitative estimation of pelagic fish eggs and larvae which occurred in the plankton collections of Tuticorin coast during 1976-85 indicated their abundance in space and time. A trimodal cycle in the distribution of fish eggs and larvae with peaks in February-March, June-July and September-October was observed, indicating the spawning seasons. A maximum occurrence of 7,584 eggs contributing to 80.6% in the composition of total zooplankton was recorded in October, 1978 coinciding the monsoon season. Hydrological and meteorological features of the area in relation to the distribution of fish eggs and larvae are briefly discussed. A variety of types of eggs and larvae sorted in the collections indicated the area as an important resourceful ground in the fishery map of Southeast coast of India.

INTRODUCTION

The most important factors that influence the fishery of a region is the magnitude of spawning intensity, egg production and availability of plankton which forms diet of the early developmental stages. It is essential to follow the cycle of events in these aspects so as to give valid predictions regarding the natural fluctuations in the abundance of fish stock. In comparison with the considerable amount of knowledge available on the Ichthyoplankton of Indian coastal waters, practically little is known on this aspect off Tuticorin in Gulf of Mannar. Chacko (1950) has described the eggs and larvae of sixteen species of fishes from Krusadai Island. Nair and Bhimachar (1950) have described eggs of eel from Gulf of Mannar. Bapat (1955) studied the occurrence, distribution and development of fish eggs and larvae of the Gulf of Mannar and Palk Bay. Based on the occurrence of fish eggs Marichamy and Pon. Siraimetan (1984) observed the maximum spawning period as March-July and existence of an inverse relationship between the larval population and other major zooplanktonic organisms. The present paper deals with the gross quantitative variations of fish eggs and larvae in plankton of the inshore waters with reference to environmental conditions and general inter-relationship of zooplanktonic organisms. The work was carried out during 1976-85, covering a stretch of 30 km along the Tuticorin coast in 6-20 m depth

MATERIAL AND METHODS

Regular weekly or fortnightly samples of zooplankton were collected from fixed stations between 06.30-08.30 hours as surface tows for 10 minutes using a half metre ring net made of nylon of 0.4 mm mesh size. The estimates were made as number per 10 minutes haul. Data on hydrological factors were also collected. The samples were preserved in 5% formalin. Fish eggs and larvae were counted numerically in the whole samples. The percentage composition of fish eggs and fish larvae were calculated in relation to other major zooplanktonic organisms, monthwise, to make the results comparable and for determination of peak spawning period.

RESULTS

Influence of hydrological factors

Observations on the environmental characteristics were made to see their influence on the distribution pattern of fish eggs and larvae and the spawning season of commercially important fishes. The monthly average values of rainfall, surface temperature, salinity and volume of plankton in relation to the occurrence of fish eggs and larvae are depicted in Fig. 1. It may be seen that there was a maximum rainfall in November (169 mm) with a secondary peak in April (34 mm). Bimodal oscillation of surface temperature and salinity was noticed with two

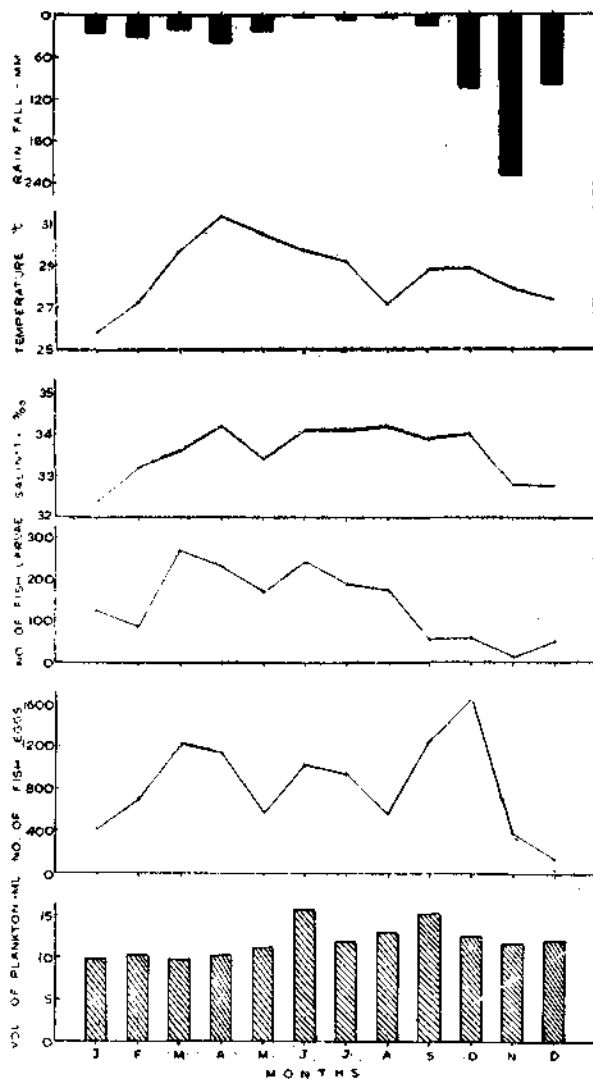

Fig. 1

peaks in April and October. It is significant to note that a maximum number of fish eggs and larvae were collected during March and October

indicating the spawning season during this premonsoon period. A third prominent season for the occurrence of fish eggs and larvae during June was also noticed although the rainfall was poor. Fish eggs and larvae of one kind or other were present almost throughout the year. Generally, an increased volume of zooplankton was recorded during February (10.3 ml), June (15.9 ml) and September (15.3 ml) coinciding more or less the peak season of the occurrence of fish eggs and larvae and spawning of other organisms.

Seasonal variations in the abundance of fish eggs

The percentage composition of fish eggs in zooplankton collections made during 1976-85 are presented in Table 1. It may be seen that the general trend of distribution was more or less identical during the period of observation of ten years. Certain types of eggs were collected round the year with definite peaks in particular months, indicating a protracted spawning season. An increased composition of fish eggs with certain exceptions was recorded in three seasons in a year i. e. February-March, June-July and again during October-November. In the rest of the months, the fish eggs were accounted either in low or negligible percentages. Fish eggs constituted a maximum of 80.5 percentage in the plankton composition during October, 1978 whereas in the corresponding month of 1985 no eggs were present in the collection. The occurrence of fish eggs was comparatively high varying from 1,098-2,390 during 1976-1980. The percentage composition

TABLE 1.
The Percentage composition of fish eggs in plankton

Year	Jan	Feb	Mar	April	May	Jun	Jul	Aug	Sep	Oct	Nov	Dec
1976	—	22.2	17.1	17.5	1.9	6.0	1.7	4.9	13.7	5.1	11.6	9.6
1977	21.6	28.8	3.5	5.8	22.8	1.1	14.7	28.5	16.6	9.0	1.1	0.2
1978	8.7	4.2	30.2	18.0	8.5	13.5	24.8	7.5	14.5	80.5	—	1.6
1979	3.5	23.5	16.6	5.3	4.3	—	6.7	0.5	—	0.2	25.5	2.7
1980	14.2	25.6	8.6	6.2	8.7	9.9	—	0.1	2.3	41.8	9.5	0.6
1981	—	14.7	3.2	0.8	1.9	—	1.1	0.5	0.3	—	2.4	3.0
1982	20.0	10.8	19.0	30.8	9.8	17.7	34.9	4.9	2.7	1.9	0	8.2
1983	0.4	0.1	3.5	7.8	0.2	0.4	3.4	—	0.3	0.2	0.6	2.3
1984	1.9	4.0	20.8	0.2	2.1	0.5	3.6	0.6	1.2	0.7	0.3	0.8
1985	1.3	1.2	1.4	1.0	19.1	0.2	0.1	5.0	0	0	1.7	0.2

of fish eggs was generally poor during the years 1981, 1983 and 1985. During these years the rainfall was also considerably low (260 mm-520 mm).

From the characteristics features of the fish eggs as described by Delsman (1926, 1929, 1931), Chacko (1950), Nair (1952) Bapat (1955) and Venkataramanujam and Ramamoorthi (1976) the presence of clupeid eggs, eggs of *Stolephorus*, Carangid and eel were noticed in most of the months. Eggs of *Stolephorus* were found with oil globules and embryo of advanced stages with two peak seasons, February-March and June-August and measured at 1.0-2.1 mm size They were more common in the collections made at Punnakayal trench.

Seasonal variations in the occurrence of fish larvae

The occurrence of fish larvae in plankton was observed round the year with three distinct peaks in a year during February-March, June-July and September-October. During September-October normally an increased trend in the surface temperature and salinity was noticed prior to the onset of northeast monsoon (Fig. 1). The observations revealed that some fishes spawn during this season. Similarly, there was peak occurrence of fish larvae during late February and March coinciding low temperature and salinity. This is indication of another spawning season.

The percentage composition of fish larvae in plankton are given in Table 2. The data indicate differences in the abundance of fish larvae in the plankton collections showing spawning seasons. In 1978 a maximum percentage of fish larvae was seen in the plankton in January than in the rest of the year including the usual spawning months. Likewise another unusual trend in the occurrence of fish larvae was noticed in August as seen in 1981 and 1982. In 1984, the fish larvae were found in negligible percentages in February-March and in the rest of the months they were completely absent.

Identification of fish larvae was possible for more common fishes with available published information. The size of the larvae, peak period of occurrence and the ground of predominant collection as well as its percentage composition in total fish larvae are tabulated and given in Table 3. Of all the groups the occurrence of larvae of *Stolephorus* spp. was high (31.5%) during February-March and again during August-October in the size range of 2.3-8.5 mm. They were more common in the collections made at Punnakayal trench and off Spic coast. The larvae of *Sardinella* spp occupied the second rank and the peaks were noticed in summer, March-May and October-December. The percentage composition was accounted to 15.5. They were measured mostly in the size 3.1-6.3 mm.

TABLE 2
Percentage composition of fish larvae in plankton

Year	Jan	Feb	Mar	April	May	Jun	Jul	Aug	Sep	Oct	Nov	Dec
1976	—	0.4	3.0	0.9	0.4	0.2	0.1	0.2	0.7	0.1	0.2	0.9
1977	3.7	5.4	0.1	0.2	0.1	0.3	0.1	0.1	0.5	0.1	0	0.1
1978	2.6	0.4	0.2	0.8	1.4	0.3	0.2	0.1	0.1	0.1	—	0.5
1979	0.4	1.0	0.7	0.1	2.1	—	1.3	0.4	—	0.4	0.8	0
1980	1.0	4.7	0.4	0.3	0.5	0.5	—	0	0.4	0.4	0.6	1.4
1981	—	0.5	0.3	0.4	0.3	—	0.8	1.6	0.1	—	0.4	1.6
1982	1.7	1.7	1.4	0.8	1.1	2.2	0.8	2.3	—	0.1	0.2	0.1
1983	0	0.1	2.8	0	0.1	0.1	0.1	—	0.2	—	—	0.2
1984	0	0.1	0.2	0	0	0	0	0	0	0	0	0
1985	0	0.2	0.3	0.1	0.4	0.1	0.1	2.1	0.1	0.1	0.1	0.1

TABLE 3.
Distribution of identified fish eggs and larvae in the plankton of Tuticorin coast.

No	Name of fish	Size range length-mm	Percentage composition	Peak season	Ground
I	Fish eggs				
	<i>Stolephorus</i> spp.	1.0-2.1	21.0	February-March and June-August	Punnakayal trench and Off Valinokkam
II	Fish larvae :				
1.	<i>Stolephorus</i> spp.	2.3-8.5	31.5	February-March and August-October	Punnakayal trench and Off Spic coast.
2.	<i>Sardinella</i> spp.	3.1-6.3	15.5	March-May and October-December	Punnakayal trench and Off Spic coast
3.	<i>Euthynnus affinis</i>	2.7-3.8	0.1	August	Off Manapad
4.	<i>Istiophorus platypterus</i>	2.9-4.9	0.2	February-March	Off Manapad
5.	<i>Rastrelliger Kanakurta</i>	3.7-3.8	0.2	July-August	Off Manapad
6.	<i>Caranx</i> spp	3.6-9.4	0.2	November-December	Punnakayal trench and Off Manapad
7.	<i>Hipdocampus</i>	9.2-19.5	0.2	November	Off Spic coast.
8.	<i>Balone</i> spp.	4.6-5.2	0.1	May	Punnakayal trench
9.	<i>Hemirhamphus obtusus</i>	19.0-25.0	0.1	January-February	Punnakayal trench
10.	<i>Leiognathus</i> spp	2.3-3.0	0.6	May	Punnakayal trench
11.	<i>Exocoetus</i> spp.	6.1-7.4	0.1	February	Off Valinokkam
12.	<i>Balistes</i> spp	3.8-4.6	0.1	February	Tholayiram paar
13.	<i>Gobius</i> sp.	5.9-8.7	0.2	December	Off Spic coast
14.	<i>Sphyræna</i> spp.	10.6-11.0	1.0	February	Off Manapad
15.	<i>Syngnathus</i> spp.	51.0-60.0	0.1	March	Off Spice coast

Larvae of *Euthynnus affinis* in the range of 2.7-3.8 mm were observed in August, in the collections made off Manapad. It is significant to note that the tuna fishery has a peak season during this same period and most of the specimens were found to have fully advanced stage of eggs. This observation further confirmed the spawning season of the species in this ground. The larvae of *Istiophorus platypterus* were collected during February-March in this same ground. The characteristic features of the larvae are the sharp, pointed snout and smaller eyes as described by Jones and Kumaran (1964). The larvae of *Leiognathus* spp were noticed in May from Punnakayal ground. The juveniles and larvae of *Caranx* spp were recorded in the size 3.6-15 mm during November-December.

Sphyræna spp. constitute an important fishery in this region. The larvae of this group was noticed in the size 10.6-11.0 during February.

Inter-relationship with other zooplankters.

Definite peak seasons were recorded for the occurrence of larvae of other organisms such as bivalves, gastropods, decapods and the dicyclic pattern of dominance of these organisms closely followed or coinciding with the abundance of fish eggs and larvae. *Appendicularians* were also seen in high numbers during this corresponding season of February-March, June and in September-October. An inverse relationship was exhibited between the occurrence of fish eggs and larvae and other major zooplankters like Lucifer.

DISCUSSION

The surface temperature and salinity exhibited a bimodal cycle of oscillation in the course of the year while the occurrence of fish eggs and larvae registered three peaks in the year, during February-March, June and September-October. Two maxima were observed in the records of rainfall, during April and November, and the peak distribution of fish eggs and larvae noticed in the preceding months March and October indicated the premonsoon spawning season of some pelagic fishes. However, the peak occurrence of fish eggs and larvae observed in June do not show any significance to the hydrological or rainfall variations, except the coincidence of the high volume of plankton in this month. Bapat (1955) recorded a bimodal occurrence of fish eggs during March and September-October, corresponding to the low surface temperature and salinity period in Mandapam area. Marichamy and Pon. Siraimeetan (1964) observed two peaks in the distribution of fish larvae, the primary one in January-February and the secondary one in June-July during 1973-74 associated with the low temperature and salinity in Tuticorin area. The present observations reveal the similarities as well as distinct differences in the spawning behaviour of fishes in Gulf of Mannar, when compared with the earlier works. As observed by Bapat (1955), the presence of majority of the types of the eggs in varying numbers during a greater part of the year indicate the protracted breeding season in many species in this region. Also Panikkar and Aiyar (1939) observed active spawning of many species during the monsoon season and attributed it to the outbreak of rains as influencing factors even in continuous breeders. The occurrence of eggs and larvae of *Stolephorus* spp during February-March and again in August-October indicated the biannual spawning season of the fish in this region. Prasad (1954) opined that the water in Gulf of Mannar are subject to considerable influences from the adjacent seas and maintenance of a planktonic population depends upon a balance of dynamic factors, such as drift of the water and its interaction with its environment as well as upon the rate of reproduction and mortality of the population. Abrupt changes in the percentage composition of fish eggs and

larvae noticed during June-August may also be due to the influence of surface currents as they may bring or carry away the plankters in the areas of investigation.

Unlike Mandapam area where two peaks in the abundance of fish eggs and larvae had been reported, in the present study three peak periods of occurrence had been recorded in the Gulf of Mannar off Tuticorin coast.

ACKNOWLEDGEMENTS

The authors are grateful to Dr. P. S. B. R. James, Director, Central Marine Fisheries Research Institute, Cochin for his keen interest and constant encouragement in the work. Thanks are also due to the Meteorological Department, Port of New Tuticorin for the supply of rainfall data. We thank Shri. M. Selvaraj, Technical Assistant for helps extended in this work.

REFERENCES

- BAPAT, S. V. 1955. A preliminary study of the pelagic fish eggs and larvae of the Gulf of Mannar and the Palk Bay. *Indian J. Fish.*, 2: 231-255.
- CHACKO, P. F. 1950. Marine plankton from waters around the Krusadai Island. *Proc. Indian Acad. Sci.*, 31 B: 162-74.
- DELSMAN, H. C. 1926. Fish eggs and larvae of the Java sea-8. *Dorosoma chacunda*. *Treubia* 8: 389-94.
- DELSMAN, H. C. 1929. Fish eggs and larvae of the Java sea 12: The genus *Engraulis*. *Treubia* 11: 275-81.
- DELSMAN, H. C. 1931. Fish eggs and larvae of the Java Sea 17: The genus *Stolephorus*. *Treubia* 13: 217-43.
- JONES, S. and KUMARAN, M. 1964. Eggs, larvae and juveniles of Indian Scobroid fishes. *Proc. Sump. on Scobroid fishes* Part 1: 343-378.
- MARICHAMY, R. and PON. SIRAI MEETAN 1964. Hydrobiological studies in the coastal waters of Tuticorin, Gulf of Mannar. *J. mar. biol. Ass India* 1979 21 (1 & 2) 67-76.

- NAIR, R. V. 1952. Studies on some fish eggs and larvae of the Madras plankton. *Proc Indian Acad. Sci.*, 35 B : 181-208.
- NAIR, R. V and BHIMACHAR, B. S. 1950. On some eel eggs and larvae from the Gulf of Mannar. *Proc. Indian Acad. Sci.*, 31 B : 331-38
- PANIKKAR, N. K. and AIYAR, R. G. 1939. Observations on breeding in brackish water animals of Madras *Proc. Indian Acad. Sci.*, 9 B : 343-64.
- PRASAD, R. R 1954. The characteristics of plankton at an inshore station in the Gulf of Mannar near Mandapam *Indian J. Fish.*, 1 : 1-36.
- VENKATARAMANUJAM, K. and K RAMAMOORTHY 1976. Studies on seasonal abundance of the fish eggs and larvae of Portonovo waters. *Indian J. Fish.*, 21 : 454-462.

PROSPECTS AND PROBLEMS OF MANAGEMENT AND DEVELOPMENT OF THE MARINE MOLLUSCAN RESOURCES (OTHER THAN CEPHALOPODS) IN INDIA

K. Alagerswami and M. M. Meiyappan
Central Marine Fisheries Research Institute, Cochin-31

ABSTRACT

Typical of tropics, India has a large variety of molluscan resources in the coastal waters and in the estuaries and backwaters. The clam resources consisting of species of *Meretrix*, *Katylisia*, *Paphia*, *Anadara*, *Villorita* and others have been exploited by the fisherfolk from time immemorial for food as also for their shells. Subsoil deposits of shells form a major resource in some of the estuaries and backwaters. The sea mussel *Perna* forms a moderate resource which is under intense exploitation in certain regions. Oyster resources (*Crassostrea*) are not extensive but collected here and there. Windowpane oyster *Pinctada* is restricted in its distribution but is well exploited. The pearl oyster resource has been unproductive since the early sixties. The gastropod resources consist mainly of *Xancus*, *Turbo* and *Trochus*, which are confined to certain regions and are heavily exploited. Other ornamental gastropods used in shellcraft industry are thinly spread out. Deepsea molluscan resources, if any, are not known except *Pirula*.

Owing to manmade changes including pollution, the distribution and abundance of the molluscan resources, especially those in the estuaries and backwaters, have changed and will be subject to further change, if left unchecked. The level of exploitation has also advanced from subsistence to mechanised operation, though on a small scale, on certain resources for industrial uses. During the last five years export of frozen clam meat has increased. Some of the molluscs are emerging as source material for bioactive substances. Taking an overall view of these changes and their probable effects on the resources, the future of the molluscan resources, which were once considered substantial, does not appear to be encouraging, unless management and conservation measures are evolved and implemented. Many States have considered the shells as a mineral resource and are operating them under leasing/licensing arrangements.

Based on the available data on exploitation of shellfish resources, an attempt has been made to estimate the all-India production of molluscs which approximates to about 70,000 t per annum (excluding cephalopods). The paper lays stress on adopting a national policy on management and development of the shellfish resources and bringing them under the mainstream of fisheries development programmes. Resource inventory, environmental monitoring, depuration of shellfish, transplantation, sea-ranching market research and screening for bioactive substances are indicated as future research and development needs. Management measures required are outlined as legislation on shellfisheries, holistic review of leasing policies of State Governments and control on export of clams and ornamental molluscs.

INTRODUCTION

India has a wide variety of molluscan resources (Hornell, 1951). The cephalopods share a common environment with the dominant

marine finfish species and, therefore, are caught in fishing gears operated for the pelagic, midwater and demersal resources. Management and development problems concerning cephalopods are in common with those of finfish

resources. The bivalves and gastropods are the sedentary groups of molluscs which generally form the basis of subsistence fisheries in the coastal waters, estuaries and backwaters and the management and development problems are different and distinct. The present paper concerns itself with these sedentary resources. Culture of molluscs is excluded from its purview.

Useful faunistic information on marine bivalves and gastropods of India has been published (Hornell, 1951). Also accounts on the fishery for these molluscs have been given by several workers (Rao, 1958; Alagarwami and Narasimham, 1973; Jones and Alagarwami, 1973; Mahadevan and Nayar, 1973; Narasimham, 1973; CMFRI, 1974; Rasalam and Sebastian, 1980). Basic biology relating to age, growth, food and reproductive cycle has also been worked out for several species of importance (Abraham, 1953; Nayar, 1955; Rao and Nayar, 1956; Johi, 1963; Ranade, 1964; Alagarwami, 1966; Narasimham, 1968). Some estimates of production for a few areas are seen in the published literature (Silas et al., 1982). A few spot surveys of molluscan resources have been carried out at different times (Alagarwami and Narasimham, 1973; Jones and Alagarwami, 1973; Narasimham et al., 1984; Nayar et al., 1984]. What has been lacking is an overall picture of the magnitude of the marine molluscan resources of the country and, as a result, production of molluscs goes unaccounted in the marine fish production estimates of the country. In order to develop a national strategy for management and development of molluscan resources such information is necessary. The paper, for the first time, makes an attempt to arrive at an all-India estimate despite an inadequate data base, with the expectation that this will motivate efforts in future to correct and refine the estimates at the State as well as national levels. Specific R & D needs and management problems of molluscan resources have been discussed.

MOLLUSCAN RESOURCES AND PRODUCTION

Clam resources

The clam resources are more dominant in the backwaters and estuaries than on the sandy

beaches. Generally they are more abundant along the west coast than on the east coast. Among the bivalves, the clams are regularly fished and utilised because of the relatively simple method of collection by handpicking or using small canoes with scoop nets. Men, women and children are engaged in the collection. Among the molluscs the clam resources offer the greatest subsistence fishery potential to the coastal fishermen. The species exploited are several and the most important ones are *Villorita cyprinoides*, *Meretrix casta*, *M. meretrix*, *Katylisia opima*, *K. marmorata*, *Paphia malabarica* and *Anadara granosa*.

Available production estimates are sketchy and limited to a few centres. These are generally based on enquiry. Some of the recent estimates (Silas et al., 1982; CMFRI, 1981-82; Narasimham, et al., 1984; Rao and Rao 1985; CMFRI, 1986) are given in Table 1. For the purpose of arriving at an estimate of exploited resources at all-India level, certain reasonable approximations are made as follows:

State	Estimated clam production (t) (vide Table 1)	Approximate production (t)
Gujarat	—	—
Maharashtra	1,100	2,000
Goa	890	1,000
Karnataka	8,210	10,000
Kerala	32,340	35,000
Tamil Nadu & Pondicherry	730	1,000
Andhra Pradesh	2,700	3,000
Orissa	—	1,000
West Bengal	—	—
	<u>45,970</u>	<u>53,000</u>

For this purpose, considering the nature of coastline and reported resources, clam exploitation in Gujarat, West Bengal, Andaman & Nicobar Islands and Lakshadweep is considered as nil.

Oyster Resources

The oyster resources are distributed throughout the coastal areas in the estuaries, backwaters and creeks. The most important

TABLE 1

Estimated annual production of clams in the maritime States of India

Area	Species	Annual Production (t)
Maharashtra		
All estuaries	<i>Meretrix meretrix</i> , <i>Katylisis opima</i> , <i>K. marmorata</i> and <i>Paphia laterisulca</i>	1,100
	Sub-total	<u>1,100</u>
Goa		
All estuaries	<i>Meretrix casta</i> and <i>Villorita cyprinoides</i>	890
	Sub-total	<u>890</u>
Karnataka		
Netravati estuary	<i>M. casta</i>	230
	<i>V. cyprinoides</i>	150
Gurpur estuary	<i>Paphia malabarica</i>	640
	<i>V. cyprinoides</i> and <i>M. casta</i>	640
Mulki estuary	<i>M. casta</i> and <i>P. malabarica</i>	3,100
Udayavara estuary	<i>M. casta</i>	250
Swarna estuary	<i>V. cyprinoides</i> and <i>M. casta</i>	20
Sita estuary	<i>M. casta</i>	380
Coondapur estuary	<i>P. malabarica</i>	
	<i>M. meretrix</i> <i>M. casta</i>	
	<i>V. cyprinoides</i> and <i>K. opima</i>	640
Uppunda estuary	<i>P. malabarica</i> <i>K. opima</i>	
	<i>M. casta</i> and <i>M. meretrix</i>	160
Kalinadi	<i>M. meretrix</i> <i>P. malabarica</i>	
	<i>V. cyprinoides</i>	2,000
	Sub-total	<u>8,210</u>
Kerala		
Vembanad Lake	<i>V. cyprinoides</i>	21,900
Ashtamudi Lake	<i>K. opima</i>	5,440
	<i>V. cyprinoides</i>	5,000
	Sub-total	<u>32,340</u>
Tamilnadu		
Vellar estuary		730
	Sub-total	<u>730</u>
Andhra Pradesh		
Kakinada Bay	<i>Andhra granosa</i>	2,000
	<i>M. meretrix</i>	400
Godavari estuary	<i>M. meretrix</i>	300
	Sub-total	<u>2,700</u>
	TOTAL	<u>45,970</u>

species is *Crassostrea madrasensis* which has a wide distribution along the entire east coast and south-west coast. It is replaced by *C. gryphoides* in the north-west coast. *Saccostrea cucullata* occurs in the intertidal rocky areas throughout the mainland coast as well as in Andaman and Nicobar Islands and Lakshadweep. The oyster beds are found in patches and except for an extensive bed at Ennore estuary in Tamil Nadu, they are small and dispersed in other regions.

Some estimates of standing stocks of oyster have been made for a few centres but production estimates are very sketchy. Oysters are collected at some centres near the cities of Bombay and Madras for supplying to hotels and at centres in Maharashtra, Goa, Karnataka and Kerala for local consumption. The exploitation estimates made are 100 t from Mulki, 75 t from Coondapur and 50 t from Sita estuaries in Karnataka totalling to 225 t, against the standing stocks of 244 t, 383 t and 91 t respectively (Rao and Rao, 1985). In the absence of any other data, considering the collection and consumption pattern indicated by Alagarswami and Narasimham (1973), the annual production of oysters in India would be of the order of 750-1000 tonnes whole weight.

Mussel Resources

Exploitation of the green mussel *Perna viridis* is confined to the northern Kerala coast from Calicut to Cannanore and the estimated annual production is about 2,900 t (Kuriakose *et al.*, 1987). The brown mussel (*P. indica*) landings in the southern extremity of Kerala are about 600 t per annum (CMFRI 1983-84). Elsewhere along the Indian coast mussel production is negligible, although collected for local consumption in places such as Ratnagiri, Goa, Karwar and Cochin. Small mussel beds occurring along the east coast in Cuddalore, Pondicherry, Ennore, Kakinada and Chilka lake are not exploited. Thus the annual production of mussels in India would be around 3,500 t.

Windowpane Oyster Resources

The present distribution of windowpane oyster (*Placenta placenta*) resource in comm-

ercially exploitable quantities is limited to the Gulf of Kutch, Kakinada Bay and Nauxim Bay (Zuari estuary in Goa). However, it is likely that this resource occurs in several other regions as well, though in smaller quantities.

In Gulf of Kutch it is distributed from Sachana to Okha, with heaviest concentration in Pindara Bay (Varghese, 1976; Sarvaiya, 1982; Pota and Patel, 1987). The standing crop estimates at Goomara, Poshetra and Raida were 90 lakhs, 12 lakhs and 1 lakh oysters. Varghese (1976) estimated an annual production of 45,00,000 oysters for a season of 5 months. The fishery used to be leased out for a term of 3 years upto 1978. But subsequently, the term of lease has been reduced to annual basis and, as reported by Pota and Patel (1987) the fishery is continuous throughout the year currently yielding about 50,00,000 oysters per month. At an average weight of 70 g per oyster (12 cm size) the annual production of windowpane oyster is calculated to be about 4,200 tonnes. The pearls collected are sold for pharmaceutical uses in indigenous system. Varghese (1976) estimated the pearl yield at 2 g per 800 oysters. At current production of about 600 lakh oysters per annum, the annual production of pearls from this fishery can be estimated to be 150 kg. The shells which form about 85% of whole weight of the oyster *i.e.* an estimated 3,570 t per annum, go for industrial uses.

Kakinada Bay is another rich ground with an estimated stock of about 8,945 t of windowpane oyster and about 43,348 t of shells of dead oysters (Murthy and Narasimham, 1979). More recent estimate of standing stock was 12,420 t (Narasimham *et al.*, 1984). The annual production by the fishery is about 5,000 t. The pearl yield of windowpane oyster in the fishery will be about 98 kg at an estimated yield rate of 1 kg of pearls per 50 t of oysters (Murthy and Narasimham, 1979). While small quantities of shells (right valve) are exported, the bulk is used in the production of shell-lime. The meat is not utilised at present.

The windowpane oyster resource of Nauxim Bay in Goa is relatively small. According to

Achuthankutty *et al.* (1979), about 8,000-10,000 oysters are fished per day throughout the year except during the monsoon season. At an average of 160 days of active fishing per year, the above production would amount to about 100 t/annum. About 35% of the population is reported to contain pearls. However, the oysters are collected for the meat which is consumed locally and for the shells. The pearls are not collected from the oysters.

From the estimates made as above, the windowpane oyster production in India from the three areas would amount to about 9,300 t/annum. The yield of seed pearls would be around 250 kg/annum which is used entirely in the pharmaceutical preparations of medicines under the Indian systems.

Pearl Oyster Resources

The pearl oyster *Pinctada fucata* populations in the Gulf of Mannar and Gulf of Kutch are highly fluctuating. During the present century the Gulf of Mannar resources yielded pearl fisheries in 1908, 1914, 1926-28 series and 1955-61 series. Except for the above 12 years, the natural beds were not productive during the remaining 75 years upto now. The most successful series of 1955-61 fishery yielded an average annual production of 109 lakh oysters, with the minimum of 11.75 lakhs in 1957 and a maximum of 214.77 lakhs in 1958. Taking the weight of 45 g for a three-year old oyster (fishery minimum), the average annual production during the above period was 488 t.

The resource in the Gulf of Kutch is of a much smaller magnitude yielding to fishery every two or three years upto 1967 but failed thereafter. Between 1950 and 1967 there have been only 7 fisheries with an average production of about 19,000 oysters amounting to 0.86 t per fishery.

By reason of their high fluctuations with a very low productive cycle, the pearl oyster resource may be considered more a bonus than a regular resource at present.

Chank Resources

The sacred chank *Xancus pyrum* has been exploited from time immemorial. The major

resources occur in the Gulf of Mannar, particularly along the Ramanathapuram - Tirunelveli coast. Chanks are also caught along Thanjavur-South Arcot - Chinglepet coast. The coastal region of Kerala from Quilon to Trivandrum has moderate chank beds. The Gulf of Kutch has a limited resource. About 90% of the production comes from skin-diving and the rest as incidental catches in the bottom trawl nets and gillnets. Aimed hook & line fishing for chanks is conducted at Vizhinjam. Some production comes from Andaman and Nicobar Islands. There is some fluctuation in the landings in all the regions. The production in numbers is averaged for the recent years as follows:

Tamil Nadu:

Tirunelveli coast	—	8,77,000
Ramanathapuram coast	—	3,00,000
Thanjavur-South Arcot-Chinglepet coast	—	40,000
Sub-total		<u>12,17,000</u>

Kerala:

Quilon-Vizhinjam coast	—	22,000
------------------------	---	--------

Gujarat

Gulf of Kutch	—	12,000
Andaman & Nicobar	—	5,000
Total		<u>12,56,000</u>

The minimum legal size for capture is 64mm maximum shell diameter in Tamil Nadu and the weight would be about 350 g. However, larger chanks weighing upto more than a kg are landed in good numbers. It is estimated that annual chank production in India will be about 1250 tonnes.

Trochus and Turbo Resources

The top-shell *Trochus niloticus* and turban-shell *Turbo marmoratus* form fishable beds in Andaman and Nicobar Islands. These resources were exploited clandestinely by shellfishing boats of other countries since 1926. After detailed studies on the two species made by Amirthalingam (1932) and Rao (1939), exploitation of the shellfishes was brought under the

control of the Administration, under the Andaman and Nicobar Islands Fisheries Regulation 1938 and rules were made under Notification of 1955. The Island territory was divided into 9 zones, namely Cape Price to Mayabunder, Cape Price to Austen Strait, Mayabunder to Long Island, Long Island to Shoal Bay, Shoal Bay to Chiriatapu, Chiriatapu to Port Mout Ritchie's Archipelago, Nicobar Central group and Nicobar Southern group. The fishing rights for each zone are auctioned. The minimum legal size for collection is 9 cm for *T. niloticus* and 6.35 cm for *T. marmoratus*. The annual production ranges 400-600 t of *T. niloticus* and 100-150 t of *T. marmoratus* (Appukkuttan, 1977).

Ornamental Molluscs

Besides *Turbo* and *Trochus* from Andaman and Nicobar Islands and *Xancus* from mainland, several species of gastropod shells are available in the Indian waters. The Gulf of Mannar, Palk Bay, Gulf of Kutch, Andaman and Nicobar and Lakshadweep are some of the areas where rich resources of ornamental molluscs are available. The shells available are *Strombus*, *Chiragra*, *Cassis*, *Cypraea*, *Harpe*, *Conus*, *Cymbium*, *Oliva*, *Murex*, *Cymatium*, *Tibia*, *Babylonia*, *Fistularia*, *Fusinus*, *Umbonium* etc. As ornamental shells, these are invaluable. The shells are regularly collected, cleaned, polished and marketed locally in several coastal towns in the form of shellcraft articles and also exported. In 1981, the maximum of 1,256 t of sea shells valued at Rs. 32.6 lakhs were exported (MPEDA 1987). The annual average of exports during 1981-85 period was 333 t valued at Rs. 15.39 lakhs. The unit price of export value for the sea shells from 1981 through 1985 was Rs. 2.60, Rs. 11.90, Rs. 7.20, Rs. 31.00 and Rs. 13.00 per kg. Taking into consideration the export tonnage and domestic sales, total annual production of ornamental sea shells would be in the order of about 600 t.

Sub-soil Shell Deposits

The major sub-soil shell deposits along the Indian coast occur in Vembanad Lake, Pulicat Lake, and Coondapur and Swarna estuaries. Besides, minor deposits occur in several other places such as Athankarai, Kovalam backwaters, Pinnakayal and Valinokkam in Tamil Nadu and

other estuaries in Karnataka. The production from Vembanad Lake includes about 53,000 t collected by fishermen cooperative societies and about 95,000 t dredged by the factories for production of calcium carbide and white cement (CMFRI, 1986). Exploitation in Pulicat Lake is around 57,000 t (Thangavelu and Sanjeevaraj, 1987), in Kovalam backwaters about 3,000 t (Thangavelo *et al.* 1987) and in Coondapur and Swarna estuaries about 50,000 t (CMFRI, 1986). Production from all other areas may amount to 25,000 t. Thus, approximately 2,78,000 t of sub-soil shell deposits are "mined" and used for industrial and shell-lime making purposes.

Export of Molluscan Products

Besides cephalopods, small quantities of other molluscan products are exported from India. Clams *Katylisia opima*, *Villorita cyprinoides* and *paphia malabarica* form the main item which entered the export trade for the first time in 1981 and picked up on a continuous basis. The products and value of molluscs exported are given in Table 2.

It is worth noting that the average unit price for frozen clam meat per kg was Rs. 710 in 1981, Rs 21.30 in 1982, Rs. 12.50 in 1983, Rs. 14.00 in 1984 and Rs. 14.30 in 1985. The percentage of counts/grades exported in 1982-83 were 300/500-2.03%, 500/700-19.26%, 700/1,000-48.27%, 1,000/1500-27.96% and 1,500/3,000-2.48. The smaller sizes 700-3,000 counts/kg together form 78.71%. With the increase in quantity exported, much smaller clams, popularly termed 'baby clam' in the export trade, have been exploited increasingly.

Estimated annual production of molluscs

No attempt has been made so far to get a total estimate of production of molluscs in India. With the sketchy data available for a few of the species at some centres and making reasonable projections to fill up the gaps, an attempt has been made here for the first time to arrive at a total production figure. The estimate has several inadequacies but would appear as a reasonable approximation for using in development programmes. The estimates are given in Table 3.

TABLE 2

Quantity and value of molluscan products exported

		1981	1982	1983	1984	1985
Frozen clam	Q	15.6	397.4	608.6	1,085.8	436.8
	V	111.3	8,478.6	7,607.8	15,250.8	6,237.4
Canned clam	Q	10.1	—	—	—	18.0
	V	185.8	—	—	—	195.5
Clam meat pickle	Q	1.6	9.2	—	—	—
	V	28.2	61.4	—	—	—
Sea shells	Q	1,256.2	82.1	231.8	28.7	68.0
	V	3,260.7	981.3	1,677.3	889.4	886.8
Oyster shell powder	Q	0.2	10.0	550.0	654.2	200.0
	V	12.0	81.0	368.0	461.1	122.8

(Quantity in tonnes; Value in '000 rupees)

Source ; MPEDA

TABLE 3

Estimated approximate annual production of molluscs (other than Cephalopods) in India

Resource	All-India annual production (t)
Clams	53,0000
Oysters	750
Mussels	3,500
Windowpane oyster	9,300
<i>Trochus</i> and <i>Turbo</i>	500
Chanks	1,250
Ornamental molluscs	600
Estimated total	68,900
Say	70,000 tonnes

MANAGEMENT AND DEVELOPMENT OF MOLLUSCAN FISHERIES

National policy

The overall fisheries policy of the country, as reflected in the main objective of fisheries development programmes, has been augmentation of fish production, increase in export

earnings of marine products and welfare of traditional fishermen. In this context fish production has usually been considered as production of finfish and crustaceans and, more recently cephalopods. The development programmes have not touched, in the least, the other molluscan resources of bivalves and gastropods. These resources have not been given any recognition except treating some of them, notably the chank, pearl oyster, window-pane oyster and the sub-soil shell deposits, as revenue-yielding items by the concerned State Governments and, for this reason, claiming State monopoly on the resources. The export sector has shown interest in exploitation of clams during the last five years purely from business motive.

These resources remain unaccounted even today, after four decades of planned development of fisheries in the country. The production estimates made at the National and State levels do not include these items, as no estimates are made by any agency. This situation arises from the fact that their exploitation is dispersed over wide areas in the estuaries and backwaters and production in subsistence fisheries cannot be estimated in the absence of a system to cover

such a situation. A deliberate attempt has been made in this paper, with all its inadequacies, to approximately estimate the production of the bivalves and gastropods landed in India which has given a figure of 70,000 tonnes per annum. Similarly, the estimated production of sub-soil deposits of shells has been arrived at 2,78,000 tonnes per annum. The number of persons directly engaged in the exploitation of these resources in various States/Union Territories will be around 20,000. Except for the hazardous job of diving and operation of the boats which are done by men, a good part of the production is accounted for by women and children. Talking an average price of Rs 2,000/tonne of live bivalves and gastropods, the nominal landed value of 70,000 t would be Rs. 14 crores. If the average price of shells from sub-soil deposits is taken as Rs. 1000/tonne the value of 2,78,000 t of shells would be Rs. 2.78 crores. Thus the total landed value of the bivalves and gastropods can be put at Rs. 16.78 crores per annum.

The molluscs are put to varied uses. The meats of bivalves and gastropods have high nutritional value. But consumption is limited, due to its least popularity and restricted food habits of people. The traditional use of shells (clams and windowpane oyster) has been for shell-lime production in village kilns. But today the shells are in great demand in several industries and pressure on the resource is increasing. Being sedentary resources, greater demand will lead to indiscriminate exploitation limiting the chances of their survival and natural replenishment through reproduction and recruitment. Pollution and man-made changes can affect them more severely and lead to total destruction of beds.

In view of the facts presented above, there is need for a greater awareness at the National and State level recognising these sedentary molluscan resources as of considerable importance and to have an appropriate policy at the National and State levels to manage and develop the resources in a judicious manner by bringing them specifically under the mainstream of fisheries development programmes.

Research and development needs

Resource inventory

In spite of several years of fisheries research in the country, the information on the molluscan resources has remained fractional. Information available in various publications has been consolidated and given, along with the results of spot surveys, by Jones and Alagarwami (1973), Alagarwami and Narasimham (1973) and Silas *et al.*, (1982). More recently, a better strategy was developed to bring out molluscan resources atlas for each maritime State. The one for Karnataka is under publication. It is realised that a single research organisation can not independently complete this task within a reasonable time frame. It should be a collaborative effort between the National and State organisations. The base-line resource information will require to be periodically updated taking into account recruitment and exploitation. Development organisations in the State will be better placed for this responsibility with technical assistance from National research organisations.

Environmental monitoring

The distribution and abundance of the shellfish are largely influenced by their environment. In a backwater or estuarine ecosystem, the environmental parameters play a more decisive role than in an open bay or gulf ecosystem. The rainfall, the amount of freshwater discharge of the rivers, tidal amplitude, temperature and salinity changes, changes in hydrogen-ion concentration, composition of substratum, discharge of pollutants from city sewerage, agricultural fields and industries, and occurrence of obnoxious blooms of planktonic organisms all contribute to the quantity and quality of production of shellfish. Recent examples of how some of these factors affect the resources are the mass mortality of *Villorita cyprinoïdes* in a part of Vembanand Lake due to problems of acidity (pH 3.65-4.85) (Pillai *et al.*, 1983) and instances of paralytic shellfish poisoning in clam *Meretrix casta* in Vayalur on Buckingham canal (Silas *et al.*, 1982) and Arikad on Kumble estuary (Indrani *et al.*, 1984) which had led to death of some people. Strict

environmental monitoring is essential in beds from which the shellfish are exploited for human consumption.

Depuration of shellfish

Today, shellfish are consumed as they are collected after cooking. The bivalves are notorious for their propensity for accumulation of pathogenic bacteria, heavy metals and other pollutants as also biotoxic substances. The PSP cases in India have been referred to above. Most of the regular shellfish consuming countries have adopted strict standards of hygiene on the shellfish marketed. However in India there is no awareness of this problem except for the experimental depuration done at the research institutes. There is need for bringing in minimum regulation on depuration of shellfish, however small the quantities are. The development agencies should provide the necessary minimum infrastructure and facilities at the collection or marketing centres. If shellfish food is to be popularised and promoted, a beginning should be made to introduce depuration techniques even at this stage.

Transplantation

Transplantation of shellfish is a simple method of culture adopted for augmenting production and improving quality. This is based on the principles that seed grounds are not always the ideal grounds for growth and that the grow-out grounds are not always ideal for fattening of meat before marketing. In India although some experimental work has been done (Narasimham, 1980; Rao and Rao, 1983), this has not been pursued to provide the required data for practising transplantation on commercial basis. With regard to edible molluscs, this is an important aspect for research and extension.

Sea-ranching has potential benefits for the open sea resources such as pearl oyster, chank, *Turbo* and *Trochus*. But in these cases seed production has to be done in the hatcheries and the juveniles released into the natural beds at appropriate size. An attempt has been made on sea-ranching of oyster (Chellam *et al.*, 1987). This is an area of research to be followed up and required technologies for production of seed, mode of ranching and monitoring have to be developed.

Popularisation and market research

Any development efforts on shellfish should be integrated with programmes on popularisation of molluscan meat as wholesome and nutritious protein food and also research on market potential. Trial marketing of oyster product carried out by the Integrated Fisheries Project of Government of India in certain parts of the country, has shown that the demand is high. There should be a product mix of other shellfish in the effort of trial marketing which should be done on a wider basis. Presently it appears to be a confidence crisis problem with regard to supply and demand. The natural resources themselves are not judiciously utilised as most clams landed in the country are marketed for the shells and rarely for the meat and the oyster resources are under-exploited or not exploited at several centres.

Bioactive substance

Many marine molluscs produce toxins or accumulate toxic substances. Hashimoto (1979) classified them as follows:

1. *Marine molluscs which cause food poisoning*
 - a) Gastropods containing tetramine in salivary gland e.g., *Neptunea* of Family Buccinidae.
 - b) Pyropheophorbide a in the digestive gland e.g., abalones *Haliotis* spp.
 - c) Ivory shell toxin in carnivorous *Babylonia japonica* (Family Buccinidae).
 - d) Coral reef snails of Family Turbinidae.
 - e) paralytic shellfish poisoning species e.g., several species of bivalves.
 - f) Venerupin toxin from *Tapes japonica*.
 - g) Bivalves infested with dinoflagellate *Gymnodinium breve*.
 - h) Japanese clam *Callista brevisiphonata*.
 - i) Giant clam *Tridacna maxima* from French Polynesia.
2. *Marine molluscs with toxic stings or bites*
 - a) Stinging toxins in cone shells. e.g., geographer's cone *Gastrodium* (*Conus*) *geographus*, tulip cone *G. tulipa*, Court cone *Darioconus* (*Conus*) *aulicus*, textile

cone *D. textile* and striated cone *Dendroconus (Conus) striatus*.

- b) Salivary gland toxins in cephalopods-
e. g., Cephalotoxin from *Sepia* and *Octopus*; Eledorsin from *Octopus Eledone*;
Maeculotoxin from *Octopus maculosus*.

3. *Other poisonous marine molluscs*

- a) Cholinesters in the hypobranchial glands
of *Murex* spp., *Thais* and *Buccinum*.
- b) Toxins from salivary glands of *Thais
haemostoma*, and *Cassia tuberosa*.
- c) Skin toxins from opisthobranchs *e.g.*,
Aplysia punctata.
- d) Toxins in midgut gland of *Aplysia
depilans*.

Most of these molluscs, at generic or specific levels, are available in the Indian waters for future research on drugs from the sea. As stated by Hashimoto (1979), even if direct use of the toxins is not expected, these can be useful as a model for synthesis or improvement of other drugs. With a rich variety of species of molluscs in the tropical Indian waters, more serious attention should be paid to screen the marine molluscs for pharmacologically active substances, *e. g.*, "anticarcinogenic, antibiotic, growth promoting or inhibiting, haemolytic, analgetic, antispasmodic, hypotensive and hypertensive agents".

Management

In the recent years, some of the maritime States and Union Territories have legislated Marine Fishing Regulation Acts and others are in the process of legislating. Rules have been framed under the Act to regulate fishing in the sea. These Acts and Rules do not touch upon the shellfish. Unless the shellfish resources are brought under the purview of the Acts, management measures cannot be introduced. It is for the Governments in the States to consider and bring the shellfish resources under the existing Act or make separate legislation. It may be noted that the *Trachus* and *Turbo* fishery is managed under the Andaman and Nicobar Islands Shellfishing Rules, 1955 under section 12 of the Andaman and Nicobar Islands Fisheries Regulation, 1938 (Regulation 1 of 1938).

The Government of Tamil Nadu exercises monopoly on the pearl oyster and chank resources. Gujarat has a similar situation. Kerala has monopoly on the chank resource. The system in the three States is concerned with the revenue accruing from the resources without plans for management and development of the resources. Several States lease out the sub-soil shell deposit resources to private parties for a number of years mostly through the Department of Mines and Geology treating the shells as minerals. These leases do not protect the overlying live clam resources nor do they control the damages caused to the environment through dredging or mining. Over a period of time, the danger to the resource will be cumulative. The pros and cons of leasing the beds for mining shells for industrial purposes should be examined holistically as the pressure for the raw material is increasing with industrial expansion.

Export of shellfish meat is recent. Clam meat of upto 3,000 count/kg is under export. The average price obtained is Rs. 14.30 per kg processed meat (1985 price). The export earning is about Rs. 64 lakhs (1985). The policy on export of clams would need to be re-examined if the clams are to be considered a source of nutrition available cheap to the coastal rural population with potential for reaching also the interior markets through proper extension strategy. In the scheme of marine products exports of the present order of Rs. 450 crores, the contribution of Rs. 64 lakhs by the clam is insignificant. If further promotion of export of clam meat is to take place, there will be more pressure on these limited sedentary resources which provide subsistence to several thousand fishermen families. Areas of collection, season, species, quantity and size for export should be regulated until a policy is adopted on the shellfish resource management.

A similar evaluation of the export of ornamental shells from the country is also called for. The average export during 1981-85 period was 333 t valued at Rs. 15.39 lakhs. The ornamental mollusc resources have limited distribution and most of the species would take many years to reach commercial size. The species of gastropods have not been studied in any manner. The gastropods are slow to grow as compared to the bivalves which have a shorter life span.

Several species of gastropods are important as resource material for bioactive substances. Under these circumstances, it may not be prudent to continue to export the ornamental shells, until the resources are investigated in detail and their critical uses are ascertained.

REFERENCES

- ABRAHAM, K. C. 1953. Observations on the biology of *Meretrix casta* (Chemnitz). *J. zool. Soc. India*, 5: 163-190.
- ACHUTHANKUTTY, C. T., S. R. SREEKUMARAN NAIR AND M. MADHUPRATAP, 1979. Pearls of the window-pane oyster, *Placuna Placenta*, *Mahasagar Bull. natn. Inst. Oceanogr.* 12 (3): 187-189.
- ALAGARSWAMI, K. 1966. Studies on some aspects of biology of the wedge clam, *Donax faba* Gmelin from Mandapam coast in the Gulf of Mannar. *J. mar. biol. Ass. India*. 8 (1): 56-76.
- ALAGARSWAMI, K AND K. A. NARASIMHAM. 1973. Clam, cockle and oyster resources of the Indian coasts. *Proc. Symp. Living Resources of the seas around India, Special Publication*, CMFRI: 648-658.
- AMIRTHALINGAM, C. 1932. Breeding of *Trochus* and preservation of the beds in the Andamans. *Curr. Sci.*, 1 (1): 31.
- APPUKUTTAN, K. K. 1977 *Trochus* and *Turbo* fishery in Andamans. *Seafood Export Journal*, 9 (12): 21-25.
- CHELLAM, A., S. DHARMARAJ AND A. C. C. VICTOR, 1987. Experimental sea-ranching of pearl oyster in the Gulf of Mannar. *Bull. cent. mar. Fish. Res. Inst.*, 39: 90-91.
- CMFRI, 1974. The commercial molluscs of India. *Bull. cent. mar. Fish. Res. Inst.*, 25: 170 pp.
- CMFRI. Annual Report 1981-82: 167pp
- CMFRI, Annual Report 1983-84: 114 pp.
- CMFRI, 1986. The clam resources. R & D Series for marine fishery resources management. *Cent. mar. Fish. Res. Inst. Cochin*. 9. 4 pp.
- HASHIMOTO, Y. 1979. Marine toxins and other bioactive marine metabolites (English translation by S. Kondo et al.). *Japan Scientific Societies Press Tokyo*, 369 pp.
- HORNELL, J. 1951. *Indian Molluscs. Bombay Nat. Hist. Society, Bombay*, 96 pp.
- INDRANI, K. H. S. V. GOWDA, M. SUBBURAJ, M. N. VENUGOPAL AND I. KARUNASAGAR, 1984. Out break of paralytic shell fish poisoning in Mangalore west coast of India. *Curr. Science*, 53 (5): 247-249.
- JONES, S. AND K. ALAGARSWAMI 1973. Mussel fishery resources of India. *Proc. Symp. Living Resources of the seas around India, Special Publication* CMFRI: 641-647.
- JOSHI, M. C. 1963. A study on clam *Kate-laysia marmorata* (Lam.), *Ph. D. Thesis* University of Bombay, 273 pp.
- KURIAKOSE, P. S., M. P. SIVADASAN AND V. G. SUNRENDRANATHAN. 1987. Fishery resource of the green mussel *Perna viridis* along the west coast of India. National seminar on shellfish resources and farming held at Tuticorin, India, 19-21 January 1987. *Cent. mar. Fish. Res. Inst. Cochin*: Abstract No. 4.
- MAHADEVAN, S. AND K. NAGAPPAN NAIR. 1973. Pearl oyster resources of India. *Proc. Symp. Living resources of the seas around India, Special Publication*. CMFRI: 659-671.
- MPEDA, 1987. Statistics of marine products exports 1985. *The Marine Products Export Development Authority*, Cochin: 263 pp.
- MURTHY, V. S. AND K. A. NARASIMHAM 1979. Survey of windowpane oyster (*Placenta placenta*) resources

- in the Kakinada Bay. *Indian J. fish.* 26 (1&2): 125-132.
- NARASIMHAM, K. A. 1968. Studies on some aspects of biology and fishery of the Cockle *Anadara granosa* (Linnaeus) from Kakinada Bay. *Proc. Symp. Mollusca. Mar. Biol. ASS. India*, pt. II: 407-417.
- NARASIMHAM, K. A. 1973. On the molluscan fisheries of the Kakinada Bay. *Indian J. fish.*, 20 (1): 209-213.
- NARASIMHAM, K. A. 1980. Culture of blood clam at Kakinada. *Mar. fish. Infor. Serv. T&E Ser.*, 23: 7-9.
- NARASIMHAM, K. A., G. S. D. SELVARAJ AND S. LALITHA DEVI. 1984. The molluscan resources and ecology of Kakinada Bay. *Mar. Fish. Infor. Serv. T&E Ser* 59: 1-16.
- NAYAR, K. NAGAPPAN. 1955. Studies on the growth of the wedge clam *Donax (Latona) cuneatus*, Linnaeus. *Indian. J. Fish.*, 2: 324-348.
- NAYAR, K. NAGAPPAN, K. RAMADOSS C. T. RAJAN AND N. SUNDARAM. 1984. Molluscan resources of Kali River estuarine system in Karnataka. *Mar. Fish. Infor. Serv. T&E Ser.*, 58: 1-8.
- PILLAI, V. K., A. G. PONNIAH, D. VINCENT AND I. DAVIDRAJ. 1983. Acidity in Vembanad lake causes fish mortality. *Mar. Fish. Infor. Serv. T & E Ser.* 53: 8-16.
- POTA, K. A. AND M. I. PATEL. 1987. Preliminary study on the fishery and biology of the window-pane oyster *Placenta placenta* Linn. in and around Poshitra, the Gulf of Kutch. National Seminar on shellfish resources and farming held at Tuticorin, India, 19-21 January 1987. *Cent. mar. Fish. Res. Inst*, Cochin, India. Abstract No. 36.
- RANADE, M. R. 1964. Studies on the biology, ecology and physiology of the marine clams. *Ph. D. Thesis*. University of Bombay, 266 p.
- RAO, K. SATYANARAYANA AND G. SYAD RAO, 1983. Experimental clam culture at Mulki, Dakshina Kannada. *Proc. Symp. Coastal Aquaculture*, MBAI, 2: 557-560.
- RAO, H. S. 1939. Consolidated report on the shell fisheries in the Andamans during the year 1930-35. *Zool. Surv. India*, Calcutta: 133 pp.
- RAO, G. SYDA AND K. SATYANARAYANA RAO. 1985. Survey of clam and oyster resources of some Karnataka estuaries. *Indian J. Fish.*, 32 (1): 74-89.
- RAO, K. V. AND K. NAGAPPAN NAYAR, 1956. Rate of growth in spat and yearlings of the Indian backwater oyster *Ostrea madrasensis* (Preston) *Indian J. Fish.* 9 (2) A: 542-579.
- RAO, K. VIRABHADRA. 1958. Molluscan Fisheries. In Fisheries of the West coast of India, Ed., by S. Jones: 55-59.
- RASALAM, E. J. AND SEBASTIAN. 1980. The lime shell fisheries of the Vembanad lake, Kerala. *J mar. biol. Ass. India*, 18 (2) (1976). 323-355.
- SARVAIYA, R. T. 1982. Window pane oyster fishery of Pindhara Bay in the Gulf of Kutch. *Seafood Export Journal* 14 (8): 25-28.
- SILAS, E. G., K. ALAGARSWAMI, K. A. NARASIMHAM, K. K. APPUKUTTAN AND P. MUTHIAH. 1982. Country report—India. In: F. B. Davy and M. Graham (Eds.), *Bivalve Culture in Asia and the Pacific* Proc. Workshop held in Singapore, 16-19 February 1982. International Development Centre, Ottawa: 34-43.
- THANGAVELU, R. K. RENGARAJAN AND P. POOVANNAN. 1987. An account on the sub-fossil shell deposits of Kovalam backwater. *Mar. Fish. Infor. Serv. T&E Ser.* 73: 5-6.
- THANGAVELU, R. AND P. J. SANJEEVARAJ. 1987. Distribution of molluscan fauna in Pulicat lake. National Seminar on shellfish resources and farming held at Tuticorin, India 19-21 January 1987. *Cent. Mar. Fish. Res. Inst* Cochin: Abstract No. 14.
- VARGHESE, M. A. 1976. Window pane oysters (*Placenta placenta* Linn) of the Gulf of Kutch. *Seafood Export Journal*. 18 (5): 25-28.

THE MORPHOLOGY OF THE ALIMENTARY TRACT IN RELATION TO FOOD OF PLATYCEPHALIDS OF PORTO NOVO COAST (ORDER: SCORPAENIFORMES).

R. Sivakumar and V. Ramaiyan

Centre of Advanced Study in Marine Biology, Annamalai University,
Parangipettai - 608 502, Tamil Nadu, India.

ABSTRACT

The interrelationships between the morphology of the alimentary tract and the food and feeding habits in five species of flat heads (Order: Scorpaeniformes) of the family platycephalidae were studied. The nature of teeth, gill rakers and the presence or absence of pyloric appendices were noted. Based on the shape and relative lengths of different parts of the alimentary tract and the types of food concerned the fishes were grouped into, (1) fish feeders and (2) Crustacean feeders. Qualitative analysis of the food of the five species of flat heads viz. (1) *Platycephalus indicus*, (2) *Sorsogona tuberculata*, (3) *Thysanophrys carbunculus*, (4) *Grammoplites scaber* and (5) *Suggrundus rodericensis* was also made and the results are discussed.

INTRODUCTION

The alimentary canal of teleosts in relation to their feeding habits has been studied by a number of investigators. Rathke (1824) was the first to make a comparative study on the alimentary tract of 56 species of plaice, flounders, dab and turbot. Kyle (1900) brought out the importance of a study of the alimentary tract as he observed differences in the course of the alimentary tract as well as in the presence or absence of pyloric appendices in various groups of flat fishes. According to him this cannot be used in taxonomical studies, since the length of intestine depends on the specialized feeding habits. Wu (1932) observed the pyloric appendices of 20 species of flat fishes. Norman (1934) opined that the shape of the alimentary tract can be used for ascertaining the generic status, contradicting Kyle (1900) who observed distinct difference in the alimentary tract of 11 species of flat fishes, but could not relate it to food habits. Svetovidov (1934) correlated the nature of food and the number of appendices in several flat fishes. Suyehiro (1934) concluded that since the digestive organs of fishes depend on their phylogeny as well as their feeding habits and may not therefore necessarily possess similar digestive

organs. Al-Hussaini (1947) found several adaptational features in the structure of the alimentary canal related to the nature of their diet in *Mulloidés quifflama*. Gohar and Latif (1959) studied the gut of some scarid and labrid fishes. Ochiai (1966) used the shape of the alimentary tract as a taxonomic character confirming Norman's (1934) view. Our knowledge of the alimentary canal of the Indian teleosts is very much limited (Ramanathan *et al* 1975).

Hence the present investigation was undertaken to study the relative importance of the different parts of the alimentary tract, in five species of platycephalids occur in similar habitats. For each individual the lengths measured were of (1) buccal and pharyngeal cavity (from lips to end of the pharyngeal region), (2) Oesophagus, (3) Stomach (upto the pyloric valve), (4) intestine and rectum, and expressed as percentages of the whole uncoiled tract.

MATERIALS AND METHODS

The material for the present study consisting of 190 specimens of *platycephalus indicus*, 98 specimens of *Sorsogona tuberculata*, 123 specimens of *Thysanophrys carbunculus*, 173

specimens of *Grammoplites scaber* and 96 specimens of *Suggrundus rodericensis* were collected weekly from the commercial trawl catches landed at Parangipettai. To study the morphology of the alimentary canal of platycephalids, the nature of mouth, kinds of teeth, gill raker, number of pyloric caeca and the position of stomach, intestine and rectum have been drawn to scale in five species of platycephalids. The relative importance of the different parts of alimentary canal of platycephalids was investigated based on the method described by Groot (1971).

OBSERVATIONS AND RESULTS

The alimentary canal consists of mouth, buccal cavity, pharynx, Oesophagus, stomach, pyloric caeca, intestine and rectum.

Mouth and Buccal Cavity:

The importance of food in the daily life of a fish is obvious and is reflected in the form of the mouth, jaws, teeth and so on. These structures present more diverse modifications than any other organ of the body. The present investigation attempts to explain such modifications which are more or less intimately associated with the mode or conditions of life, the manner of obtaining food and the nature of the diet itself. Mouth is relatively very wide in *P. indicus* than in *S. tuberculata*, *T. carbunculus*, *G. scaber* and *S. rodericensis*. The lower jaw of all

platycephalids are slightly projecting forward than the upper jaw. The mouth is provided with vomerine and palatine teeth. A 'tongue' is present in all species and it is flat at the tip than behind. Teeth are of villiform type but those on upper jaw at the symphyseal region pointed in a crescent shaped band on vomer and in two narrow longitudinal bands on palatines (Fig. 1). Some on vomer and palatines are slightly pointed (on vomer the pointed teeth are at the end of the crescent) only in *Platycephalus indicus* whereas in *Sorsogona tuberculata*, *Thysanophrys carbunculus*, *Grammoplites scaber* and *Suggrundus rodericensis* the villiform teeth in jaws appear as two distinct oval patches on vomer and in two narrow elongate bands on palatines. Few teeth on vomer and palatines are pointed. Palatine teeth is relatively very much prominent and distinct in *P. indicus* whereas in others the palatine teeth are very small. The buccopharyngeal region is relatively lengthy both in *P. indicus* and *T. carbunculus* (21%) but less in *S. tuberculata* (19%) and in *G. scaber* and *S. rodericensis* 20% each.

Pharynx :

The pharyngeal cavity is relatively narrow than the buccal cavity. Four pairs of gills hang down on either side of the pharynx. Since the platycephalids are carnivorous fishes, the roof of the pharynx is formed of a prominent thick pharyngeal pad divided by a median shallow line into the right and left lobes. The pharynx becomes narrower posteriorly and gradually attaining a cylindrical shape merging into the oesophagus. Gill rakers on first arch ranges

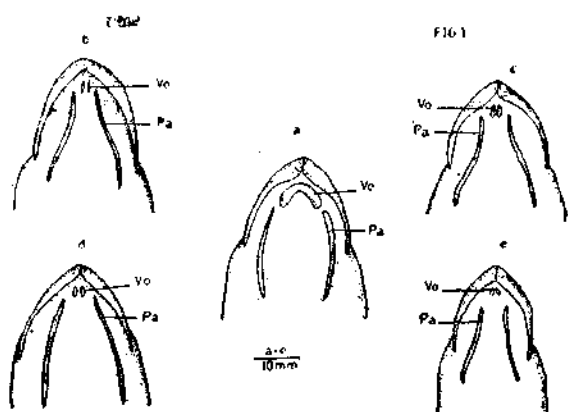

Fig. 1. Arrangement of teeth in
 (a) *Platycephalus indicus* (b) *Sorsogona tuberculata* (c) *Thysanophrys carbunculus*
 (d) *Grammoplites scaber* (e) *Suggrundus rodericensis* Vo = Vomerine teeth, pa = palatine teeth.

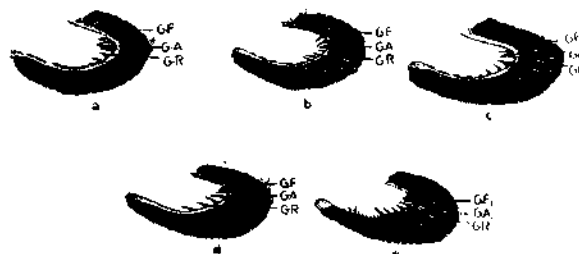

Fig. 2. The arrangement of of gill rakers on first gill arch.
 (a) *Platycephalus indicus* (b) *Sorsogona tuberculata* (c) *Thysanophrys carbunculus*
 (d) *Grammoplites scaber* (e) *Suggrundus rodericensis*
 G.F. = Gill Filament G.A. = Gill Arch
 G.R. = Gill Rakers.

from 3-4 in *P. indicus*, 2-5 in *S. tuberculata*, 2-3 in *T. carbunculus*, 2-4 in *G. scaber* and 2-6 in *S. rodericensis* (Fig 2). Each gill raker is provided with numerous serrae in all the 5 species of platycephalids. These spines are microscopic in nature however there is no significant variation between them.

Oesophagus:

The oesophagus is a short, slender, cylindrical tube constituting 7% in *P. indicus*, 4% in *S. tuberculata*, 6% each in *T. carbunculus* and *G. scaber* and 5% in *S. rodericensis*. The walls of the oesophagus are thick and the mucosal folds run longitudinally. The junction of the oesophagus with the stomach is marked externally by a slight constriction. Relatively small oesophagus (4%) is evident in *S. tuberculata* of all the species studied. Another unique adaptation of oesophagus is the great distensibility.

Stomach and pyloric caeca :

The stomach is divisible into two regions the anterior cardiac region, and the posterior pyloric region in all five species of platycephalids. This difference is visible externally as well as internally. In the cardiac region is a small out-growth of tube from posterior or anterior part of the cardiac region (Fig. 3) The stomach is relatively large and distinct in *S. rodericensis* (17%) followed by *P. indicus* and *S. tuberculata* (16%). Relatively small stomach could be seen in *G. scaber* and *T. carbunculus* among the representative of platycephalids (Fig. 4). The relatively large stomach in *S. rodericensis* may be useful to accommodate the large sized organisms on which it feeds (Fig. 3e).

Though the pyloric appendices are well developed in all the species of platycephalids, intraspecific variation is significant in this structure. The pyloric appendices usually ranges from 9 to 10 in *P. indicus*, 4 to 5 in *S. tuberculata*, 7 in *T. carbunculus*, 5 to 6 in *S. rodericensis*,

Intestine and rectum :

There is a distinct constriction between the stomach and the intestine has a single ascending loop and 2 desending loops. The intestine and

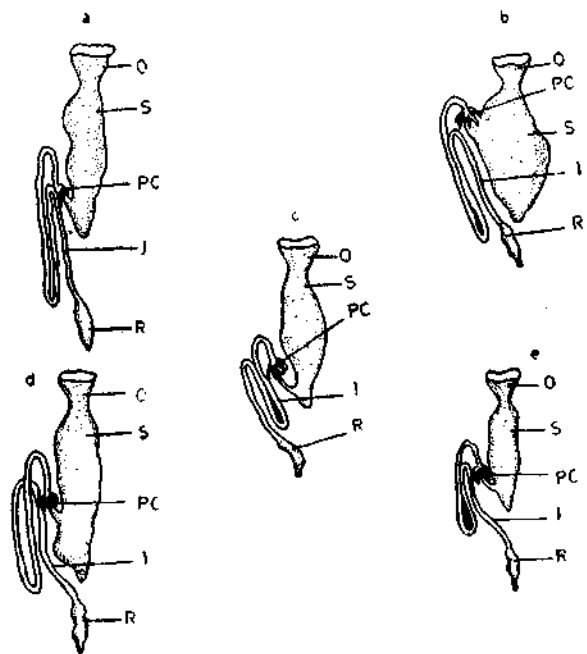

Fig. 3. Shape of the alimentary tract of

- (a) *Platycephalus indicus* (b) *Sorsogona tuberculata* (c) *Thysanoperys carbunculus* (d) *Grammoplites scaber* (e) *Suggrundus rodericensis*.

P = Pharynx O = Oesophagus S = Stomach
I = Intestine R = Rectum.

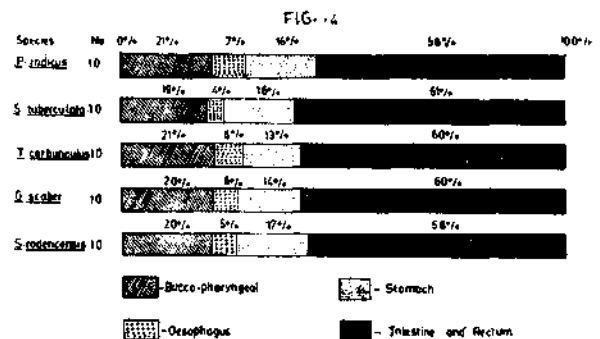

Fig. 4. Relative lengths of different parts of the alimentary tract of

Platycephalus indicus, *Sorsogona tuberculata*, *Thysanoperys carbunculus*, *Grammoplites scaber*, *Suggrundus rodericensis*.

rectum are relatively lengthy in *S. tuberculata* (61%) followed by *T. carbunculus* and *G. scaber* (60% each), *S. rodericensis* (58%), and *P. indicus* among the representatives of platycephalids (Fig. 4). The rectum is wider than intestine and its walls are also thick in nature. A narrow constriction is apparent between the rectum and intestine (Fig 3).

DISCUSSION

Norman (1934) rightly pointed out that the shape of the digestive tract provides a useful taxonomic character but he failed to correlate the shape of the digestive tract with the nature of food.

From the results of the present study on the morphology of the alimentary tract in relation to food in five species belonging to five genera of the family Platycephalidae it is possible to distinguish 2 groups of platycephalids each with its own characteristics with respect to the shape of the digestive tract, the intestinal loop and the nature of the gill rakers.

Group 1 Fish feeders—*P. indicus*,
T. carbunculus,
G. scaber and
S. rodericensis.

Group 2. Crustacean feeder—*S. tuberculata*.

The above subdivision is supported by the relative dimension of the different sections of the alimentary cavities together with the oesophagus and the stomach form about 44% of the whole tract in *P. indicus*, about 42% in *S. rodericensis* and 40% each in *T. carbunculus* and *G. scaber*. However the buccal, pharyngeal cavities together with the oesophagus and stomach were insignificant in *S. tuberculata* (39%). The significance of these differences could be explained if we consider the type of food taken by these fishes. *P. indicus*, *T. carbunculus*, *S. rodericensis*, and *G. scaber* are fish feeders besides smaller crustaceans in negligible amount. Since they feed mostly on fishes, they need a storing space which is evidently seen in the relatively more percentage of this region.

On the other hand *S. tuberculata* feeds predominantly on the crustaceans where a distinct stomach (39%) is not advantageous but a lengthy intestine (61%) is useful. The structure of the gill raker also gives an indication of the nature of the food consumed by the fish. Gill rakers are useful to fish feeders since they prevent the prey swallowed alive, to struggle out of the mouth. Therefore they have to be large and evidently the gill rakers are relatively well developed among the fish feeders (*P. indicus*,

T. carbunculus, *G. scaber* and *S. rodericensis*) however not well developed and they are microscopic in *S. tuberculata* (Fig. 2).

Further Svetovidov (1934) has stated that pyloric caeca increase in number with the size of the food which is evidently true in *P. indicus* as a result of the present study but not true in other species of platycephalids. Though there is similarity in the nature of the palatine teeth among the platycephalids distinct and significant variation has been observed in the vomerine teeth of *P. indicus* which is crescent shaped (Fig 1a); whereas in other species it is in the form of two small patterns (Fig. 1b, c, d, e). The well developed vomerine teeth in *P. indicus* may aid in food gathering.

ACKNOWLEDGEMENTS

We are extremely thankful to Prof. V. K. Venugopalan, Director, CAS in Marine Biology for providing facilities and encouragement. The first author is grateful to the I. C. A. R., New Delhi for the award of a Senior Research Fellowship.

REFERENCES

- AL-HUSSAINI, A. H. 1947. The feeding habits and the morphology of the alimentary tract of some teleosts living in the neighbourhood of the Marine Biological Station, Ghardaqa, Red Sea. *Publ. mar. biol. stn. Ghardaqa*, 5, 1-61.
- *GOHAR, H. A. F. AND A. F. A. LATIF. 1959. Morphological studies on the gut of some scarid and labrid fishes. *Publ. Mar. Biol. Stn. Alghardaqa. Egypt. No. 10:145-189.*
- GROOT, S. J. DE. 1971. On the interrelationship between morphology of the alimentary tract, food and feeding behaviour in flat fishes (pisces Pleuronectiformes). *Neth J. Sea. Res.* 5:121-196.
- KYLE, H. M. 1900. The classification of flat fishes (Heterosomata). *Fish. Bd. Scot.* 1900, 335-369.
- NORMAN, J. R. 1934. A systematic monograph of the flat fishes (Heterosomata). I. Psettodidae, Bothidae, Pleuronectidae. British Museum, London, 459 pp.

- OCHIAI, A. 1966. Studies on the comparative morphology and ecology of the Japanese Soles. *Spec. Rep. mar. biol. Inst. Kyoto Univ.* 3, 1-97.
- RAMANATHAN, N., V. RAMAIYAN AND R. NATARAJAN, 1975. On the interrelationships between the morphology of the alimentary tract and food and feeding habits of flat fishes of Porto Novo (Order: Pleuranectiformes). *Bull. Dep. Mar. Sci. Univ. Cochin.* VII, 3: 529-536.
- RATHKE, A. 1824. 1824. Beiträge zur Geschichte der Thierwelt. I. Über den Darmkanal der Fische. *Schr. naturf. Ges. Danzig* 2 (3), 1-116.
- SUYEHIRO, Y. 1934. Studies on the digestive system and the feeding habits of the important fishes of the North Pacific. II. The Plaice, *Lepidopsetta mochigarei* (Snyder) and the halibut, *Hippoglossoides elassodon* (Jordan and Gilbert). *Bull. Jap. Soc. Scient. Fish.* 3: 65-72.
- *SVETOVIDOV, A. 1934. On the correlation between the character of food and the number of pyloric caeca in fishes. *Dokl. Akad. Nauk. SSSR.* 3:70-72.
- *WU, H. W. 1932. Contribution a l'étude morphologique et systematique des poissons Heterosomes (Plsces, Heterosomata) de la Chine. 17 8pp., 27 figs. (Theses presentes a la faculte der Sciences de l'Universite de paris).

*Not referred to in original.

AN ASSESSMENT OF DEMERSAL STOCKS IN THE SOUTHWEST COAST OF INDIA WITH PARTICULAR REFERENCE TO THE EXPLOITABLE RESOURCES 'IN OUTER CONTINENTAL SHELF AND SLOPE

D. Sudarsan, M. E. John and Antony Joseph
Fishery Survey of India, Bombay

ABSTRACT

In spite of added inputs, the increase in marine fish production in India has been only marginal during the last several years. In some segments of the coast, exploitation of target species have apparently reached the level of MSY. But in the case of some other species, wide gaps exist between the estimates of stock size and the actual level of exploitation. A general awareness has rightly been created that shrimp-oriented growth of industry is rather limited and further addition to production can largely be realised only by exploiting the stocks of outer shelf and continental slope.

In this paper, an attempt has been made to assess the exploitable stocks off southwest coast between 8° North and 15° North latitudes, covering Kerala and Karnataka coasts. Several estimates of stock sizes projected by different authors were mostly based on indirect methods or fragmentary data. Recent data available has been analysed in the light of increase in fishing pressure and the estimates of the resources have been revised.

Trawl survey data collected by 17.5 m vessels from inner shelf area up to 50 m depth and the data collected by the larger vessels up to the continental slope are considered. From the catch and effort data, stock density by the swept area method is worked out for each depth zone separately for Kerala and Karnataka coasts. Quantitative assessment is made on the major demersal stocks, viz., rays, catfish, perches, nemipterids, lizard fish; carangids, bull's eye, green eye, black ruff, cephalopods, deepsea lobsters and deepsea prawns. The density indices are converted to absolute standing stock estimates. MSY figures for the species mix as well as for the major species are computed with due regard to the mortality parameters and present level of exploitation.

INTRODUCTION

The national output from marine fisheries sector in India has been growing at slow rate

during the last two plan periods, in spite of mechanisation and addition to the fishing fleet of the country. Though the potential of exploitable fishery stocks in Indian seas

have been placed at a higher order, the present marine fish production is about 1.78 million tonnes as in 1984 (Anon, 1986). Contributing about 30-35 percent of demersal landings in the country, south west coast is subject to the most intensive fishing pressure. Even though the production is well below the estimated assessments of potential yield, the trend in catches is not indicative of any significant expansion of fishery in the coastal belt. The shrimp oriented growth of industry has resulted in exploitation of stocks from a narrow coastal belt, thereby leaving the resource in the outer shelf and continental slope virtually unexploited. Availability of some of the coastal species has been considerably reduced in recent years indicating signs of strain on the stocks. Such a scenario calls for re-assessment of the size and state of fishery stocks in different sections of the Indian coast. This paper attempts an assessment of the stock size and sustainable yield level of demersal resources off the south west coast between lat. 8° to 15°N upto 500m depth.

DATA SOURCE

The estimates are made on the basis of data collected in exploratory cruises of Fishery Survey of India vessels during April, 1980 to March, 1987. Extensive coverage of different latitudes and bathymetric zones was made in the survey as listed in Table 1. 11,315 hours sampling was done by 17.5m vessels in the coastal belt within 50m depth and 588 hours survey was accomplished by the larger vessels Matsya Nireekshani, Matsya Shakti and Matsya Vishwa in the outer shelf and continental slope.

METHODOLOGY

The density of demersal stock as well as the major components were worked out by applying the 'swept area' method. The area covered in one hour was worked out taking the trawling speed of 2 knots for the 17.5m vessels and 3.5 knots in case of the larger vessels. Horizontal spread of the gear was taken as 40% of the head rope length.

The fish density per unit area was calculated separately for Kerala and Karnataka coasts in the different depth strata. A catchability coefficient of 0.5 was considered for the different gears except for the 34m fish trawl operated by Matsya Nireekshani. This gear, having mesh size in the range of 80-400 mm, was assumed to have a reduced catchability coefficient of 0.4. The stock density was further converted to absolute biomass for each strata in the northern and southern regions and then summed up.

Due to the different levels of exploitation, calculation of MSY required different approaches. The coastal areas within 50m depth is under intensive exploitation and the MSY is computed by the expression $Y_{max} = 0.5 (Y + MB)$ where Y is the current yield, M is natural mortality coefficient and B, the biomass (Gulland, 1983). Beyond the 50m depth line the demersal stocks are virtually unexploited and the MSY estimate is arrived at by applying the formula $Y_{max} = 0.5 M B_v$, where B_v is the virgin standing stock (Gulland, 1971).

In South East Asian demersal trawl fisheries, the above equations are generally used in conjunction with value of $M = 1$, considering these fishes as relatively small and short-lived. Pauly (1983) suggests that this value is essentially a guess work and has been uncritically applied to a wide variety of stocks, including multispecies stocks. Sainsbury (1979) has discussed the negative consequences of its use. Gulland (1979) has suggested a more conservative estimate of 0.5 for western Indian Ocean south of equator. From the catch components of demersal stocks in south west coast, several of the species cannot be categorised as small or short-lived. (elasmobranchs, perches, catfish etc). With due regard to the mortality parameters of related species in other tropical fisheries the natural mortality factor is roughly taken as 0.5 in case of rays, perches and cat fish, 1.5 for deep sea prawns and cephalopods and 1.0 for the other species. These values are obviously first approximations which need refinement with the parameter estimations, of major species in our own fisheries.

TABLE 1

Distribution of sampling effort and vessel & gear employed

Latitude	Depth range	Sampling hours	Vessel	Period	Gear
8°-12°	below 50m	6289	Utpadak & Sachetak	April, '80-May,83	24m Fish trawl
	50-200m	1971	Nireekshani	May-Sept. 83, Aug. 85 - March,83	34 m Fish trawl
	200-500m	697	Nireekshani	May, 85 March, 87	45m shrimp trawl
12°-15°	below 50m	5026	Pradata, Tarangini & Anavashak	April, 80-Nov, 84	24m fish trawl
	50-200m	3050	Shakti, & Vishwa	April, 83-March,87	27m fish trawl
	200-500m	170	Sakthi & Vishwa & Jan,86-March,87	April, 84-March 85,	47m shrimp tawl

TABLE 2

Stock density and standing stock of demersal resources along South West coast between LAT. 8° to 12°N

Latitude	8° to 12°N							
	Below 50m		50-100m		100-200m		200-500m	
Area (Km ²)	14150		13310		3505		6180	
Stock Density kg/kg ²) Standing Stock (tonnes)	Density	Standing Stock	Density	Standing Stock	Density	Standing Stock	Density	Standing Stock
Rays	451	6382	157	2090	10	35	3	19
Perches	53	750	219	2915	15	53	19	117
Cat fish	1236	17489	844	11234	4	14	—	—
Lizard fish	149	2108	266	3640	107	375	6	37
Nemipterids spp.	1053	14900	1672	22254	2613	9157	—	—
Caranx spp.	130	1840	53	705	47	165	—	—
Priacanthus spp.	28	396	437	5816	944	3309	14	87
Centrolophus spp	—	—	—	—	91	319	1406	8689
Chlorophthalmus spp	—	—	—	—	436	1258	992	6131
Other deep sea fishes	—	—	—	—	—	—	578	3572
Deep sea prawns	—	—	—	—	—	—	690	4264
Deep sea lobster	—	—	—	—	—	—	570	3524
Cephalopods	196	2773	396	5271	36	126	—	—
Other varieties	1608	22764	924	12299	2102	7367	106	655
TOTAL	4904	69392	4968	66124	6405	22450	4384	27094

STOCK DENSITY AND STANDING STOCK

The density of demersal stocks along Kerala coast ranged from 4.4 tonnes to 6.4 tonnes per km in the different depth strata. Highest stock density of 6.4 tonnes per km² was recorded in the 100-200m depth zone followed by 5.0 tonnes per km² in 50-100 m zone. The density along Karnataka coast was comparatively low in all depth ranges, the maximum of 4.1 tonnes per km² being in the inner shelf areas. The stock density of demersal resources in the different sections of the coast are given below.

Latitude	Stock density (tonnes per km ²)			
	Depth (m)			
	below 50	50-100	100-200	200-500
8° -12°N	4.9	5.0	6.4	4.4
12°-15°N	4.1	2.9	3.8	3.7

The density figures have further been worked out for the major species/groups furnished in Tables II and III. It can be seen that cat fish and thread-fin breams constitute the dominant varieties in the coastal areas within 50m depth. In the 50-100m depth zone, besides the above varieties, 'Bulls eye' (*Praicanthus spp*) forms a major component whereas in 100-200 m thread-fin breams and 'Bulls eye' dominate the stock. The continental slope in 200-500m depth supports high densities of 'Black ruff' (*Centrolophus sp*), 'Green eye' (*Chlorophthalmus sp*), deep sea prawns and deep sea lobster.

The standing stock in the two regions of the coast is assessed as 1.85 lakh tonnes in lat. 8°-12°N and 1.85 lakh tonnes in lat. 8°-12°N and 1.47 lakh tonnes in lat. 12°-15°N. Break up details in different bathymetric zones are given below.

TABLE 3

Stock density and standing stock of demersal resources along south west coast between LAT. 12° to 15°N

Latitude	12° to 15°N								
	Depth strata		Below 50m	50-11m	100-200m	200-500m			
Area(Km ²)			1445	16950	6740	3930			
Stock Density (kg/km ²)	Density	Standing stock	Density	Standing stock	Density	Standing stock	Density	Standing stock	
Standing Stock (tonnes)									
Rays	102	1444	46	780	49	330	2	8	
Perches	88	1246	63	1068	74	499	—	—	
Cat fish	1445	20464	518	8780	81	546	—	—	
Lizard fish	66	934	125	2119	439	2659	213	837	
Nemipterids spp	548	7757	483	8187	1788	12501	—	—	
Caranx spp	73	1033	143	2424	13	88	—	—	
Praicanthus spp	363	5138	536	9085	810	5459	271	1065	
Centrolophus	—	—	15	254	79	532	2077	8163	
Chlorophthalmus spp	—	—	—	—	—	—	—	—	
Other deep sea fishes	—	—	—	—	—	—	319	1254	
Deep sea prawns	—	—	—	—	—	—	600	2358	
Deep sea lobster	—	—	—	—	—	—	118	464	
Cephalopods	84	1190	132	2237	136	917	—	—	
Other varieties	1344	19024	798	13526	302	2036	143	561	
TOTAL	:	4113	58220	2859	48460	3771	25417	3743	14942

Latitude	Standing stock ('100 tonnes)				
	Depth (m)				
	below 50	50-100	100-200	200-500	Total
8° -12°N	69.4	66.1	22.4	27.1	185.0
12°-15°N	58.2	48.5	25.4	14.9	147.0

For standing stock estimates of major species reference may be made to Tables II and III.

POTENTIAL YIELD

The aggregate potential yield of demersal stocks in south west coast is assessed as 2.4 lakh tonnes. The depth wise distribution of the harvestable yield is estimated in Table IV, the gist of which is given below.

Depth (m)	Potential yield ('00 tonnes)				
	below 50	50-100	100-200	200-500	Total
Potential yield	140.6	52.6	24.2	22.8	240.2

DISCUSSION

The potential yield estimate arrived at in this paper is below the assessments by several earlier authors. In adequacy of data in the past

and variations in the methodology adopted for estimation of stock density as well as MSY are of the assessment of demersal stocks of south west coast is given below.

Author	Region latitude	depth range (m)	p. y. (lakh tonnes)
Silas (1969)	Cape Comorin-Karwar	75-450	0.59
Jones & Banerji (1973)	South west Coast	0-180	1.51
Mitra (1973)	Kerala & Karnataka	0-75	0.86
Joseph <i>et al</i> (1973)	Kerala & Karnataka	0-75	1.15
George <i>et al</i> (1977)	Kerala, Karnataka & Goa)	50-200	3.25
Joseph (1980)	Lat. 7°-15°	0-73	3.77
Oomen (1985)	Lat. 7°-13°	180-460	0.26
Joseph (1987)	Lat. 7°-15°	0-100	2.49
		100-200	0.27
		200-500	0.27
Present study	Lat. 8°-15°	0-50	1.41
		50-100	0.53
		100-200	0.24
		200-500	0.23

TABLE 4

Potential yield of demersal resources along south west coast 8° to 15°N

Depth (m)	'000 tonnes									
	Below 50		50-100		100-200		200-500			
	Current Yield	St. Stock	P. Y	St. Stock	P. Y	St. Stock	P. Y	St. Stock	P. Y	
Rays	5.9	7.8	4.9	2.9	0.7	0.4	0.1	—	—	
Perches	2.8	2.0	1.9	4.0	1.0	0.6	0.2	—	—	
Cat fish	16.8	37.9	17.9	20.0	5.0	0.6	0.2	—	—	
Lizard fish	5.1	3.0	4.1	5.7	2.9	3.3	1.7	0.9	0.5	
Nemipterids spp	30.5	22.7	26.6	30.4	15.2	21.2	10.6	—	—	
Caranx spp	3.9	2.9	3.4	3.1	1.6	0.3	0.2	—	—	
Priacanthus spp	—	5.5	2.8	14.9	7.5	8.8	4.4	1.2	0.6	
Centrolophus spp	—	—	—	0.3	0.2	0.9	0.5	16.9	8.5	
Chlorophthalmus spp	—	—	—	—	—	1.5	0.8	6.1	3.1	
Other deep sea fishes	—	—	—	—	—	—	—	6.1	3.1	
Deep sea prawns	—	—	—	—	—	—	—	6.6	5.0	
Deep sea lobster	—	—	—	—	—	—	—	4.0	2.0	
Cephalopods	3.4	4.0	4.7	7.5	5.6	1.0	0.8	—	—	
Other varieties	106.8	41.8	74.3	25.8	12.9	9.4	4.7	—	—	
TOTAL :	175.2	127.6	140.6	112.6	52.6	48.0	24.2	41.8	22.8	

The present estimate is closely comparable with the recent assessment by Joseph (1987) in so far as the depth zones of 100-200 m and 200-500 m are concerned. The differential approach and variations in the extent of area considered in most of the earlier reports render any critical comparison rather difficult.

The level of exploitation of demersal stocks in south-west coast is about 1.75 lakh tonnes per annum (1980-84) harvested exclusively from the coastal region within 50m depth. This exceeds the potential yield estimate of 1.41 lakh tonnes assessed here from the relative inshore area. A cautious approach possibly with reduction in fishing pressure on the demersal stocks in the coastal belt appears necessary.

A potential yield of 52,600 tonnes is harvestable from the 50-100 m depth zone. Apart from the operation by a few chartered vessels, the resources are totally unexploited. P. Y. in the order of 5600 tonnes of cephalopods from this strata and comparatively high stock density particularly in the southern grounds is highly significant. The bulk of nemipterid stock in 50-200m is capable of supporting very high returns in quantitative terms. Potential yield of this group from the unexploited zone is about 25,800 tonnes. The next stage in development of Indian marine fishery has to be with accent on exploitation of stocks from 50-100m depth zone by suitable type of vessels.

It is found that with increasing depth the quantity of low value fish increases. But the positive aspect of the stock structure in the continental slope (200-500m) is the availability of deepsea crustaceans in considerable magnitude. A potential yield of 5000 tonnes of deepsea prawns and 2000 tonnes of deepsea lobster is assessed from the Kerala - Karnataka coast with high stock density in Quilon Bank. The area can further support an yield of 15,300 tonnes of deepsea fishes. Development of appropriate technology for production of value added fish products from the deepsea demersals appears inevitable for expansion of fishery to the continental slope.

REFERENCES

- ANON, 1986. Handbook of fisheries statistics, 1986. Ministry of Agriculture, New Delhi.
- GEORGE P. C., B. T. ANTONY RAJA AND K. C. GEORGE, 1977. Fishery resources of the Indian Economic Zone. *Souv. Integrated Fisheries Project*, Silver Jubilee Celebrations 79-120 p.
- GULLAND, J. A., 1971. The fish resources of the Oceans. West Byfleet Survey, Fishing News (Books) Ltd, For FAO. 255 p.
- GULLAND, J. A., 1979. Report of the FAO/IOP Workshop on fishery resources of the western Indian Ocean south of the Western Indian Ocean south of equator, FAO, Rome. *FAO/DEV/79/45*: 1-37.
- GULLAND, J. A., 1983. Fish Stock Assessment Vol. I. A manual of Basic Methods 223 P.
- JONES, S. and S. BANERJI, 1973 A review of the living resources of the Central Indian Ocean, *Proc. Symp. on living Resources of the around India*. Spl. publication CMFRI 1-17 p.
- JOSEPH, K. M., 1980. Comparative study of the Demersal fishery resources of the Indian waters as assessed by 17.5, trawlers *Bull. Expl. Fish. Proj.* No 10:40 p.
- JOSEPH, K. M., 1987. The fish resources of the Indian Exclusive Economic Zone.
- JOSEPH, K. M., N. RADHAKRISHNAN AND K. P. PHILIP, 1976. Demersal fishery resources off the South West Coast of India. *Bull. Expl. Fish. Proj.* No. 56p.
- MITRA, G. N., 1973 Method of estimation of fish abundance in the Indian seas and steps to be taken for management of the commercial fisheries. *Proc.*

Symp. on living resources of the seas round India, Special publication, 45-154.

VARGHESE, R, 1985. Deep Sea resources of the South West coast of India. *Bull No. 11* IFP, Cochin.

J., 1983. Some simple methods or the assessment of tropical fish

stocks. *FAO Fish. Tech. Pap.* (234): 52 p.

SAINSBURY, J. KEITH., 1979. CSIRO defining fish stocks on NW Shelf. *Austr Fish.* 38 (3): 4-12.

SILAS, E. G., 1969. Exploratory fishing by R. V. Varuna. *Bull. Cent. mar. Fish. Res. Inst.* 6: 1-69.

TREND OF THE MAJOR EXPLOITED MARINE FISHERY RESOURCES OF INDIA DURING 1961-'85

M. Srinath

Central Marine Fisheries Research Institute, Cochin - 682 031

ABSTRACT

The annual estimated total marine fish landings in India during 1961-'85 are given. The contributions of the four regions namely North east, South east, South west and North west to the total landings are presented. The trends in the landings of some of the major exploited resources are depicted. Estimates of the potential yields of the major fishery resources are also indicated. Strategies for monitoring and rational exploitation of the fishery resources are also indicated along with the future perspective.

INTRODUCTION

Marine fish landings in India have registered a three fold increase from about 5 lakh tonnes in the early fifties to about 15 lakh tonnes in the eighties. The realisation of the export potential of the marine products especially prawns has resulted in substantial increase of mechanised fishing craft mainly, the small trawlers aiming primarily for exploitation of the prawns. This prawn induced growth has also helped in higher landings of other resources associated with the trawl fishery. Added to this the introduction of purse seiners in the early eighties to exploit the pelagic resources such as oil sardine, mackerel, white bait etc., and motorisation of indigenous craft has helped to certain

extent sustain the growth of marine fish landings. But this process has brought in its wake conflicts between the traditional and the mechanised sector. In spite of better capture techniques there are indications, of stagnation in the marine fish landings. The area of exploitation along the coast is mainly restricted to 0.50 m depth and remained so even with the technological changes in the capture techniques. This over intensification of effort to a certain extent might have contributed to the stagnation. This reduced growth rate has prompted the fishery managers and policy makers to look beyond the 50 m depth and advocate deep-sea fishing. At present this venture is still in the infant stage and directed towards exploitation of prawns which have better export value. The analysis of

complex multiger, multi-species nature of Indian marine fisheries is very complicated and demanding. In this paper an attempt is made to study the trends of the major exploited resources. The potential harvestable yield is also indicated. Strategies for monitoring and rational exploitation of the resources are also given. The marine fish landings during 1961-'85 form the data base for the present study covering the period from the initial stage to the present stage of mechanisation.

THE LANDINGS

The marine fish landings in India are estimated by the well planned multistage stratified random sampling scheme. The total landings in the country during 1961-85 are given in Table-1. It is clear from the table that the landings have increased tremendously from 6.4 lakh tonnes in 1962 to 16.3 lakh tonnes in 1984. The period under consideration is classified into 5 groups by considering the average landings during 1961-65, 1966-70, 1971-75, 1976-80 and 1981-85. These groups cover the entire period from the initial stages of mechanisation to the present stage and designated as S1, S2, S3, S4 and S5. The average annual landings during these five stages are as follows:

Stage:	S1	S2	S3	S4	S5
Landings:	7.35	9.31	12.00	13.31	15.03

(Lakh tonnes)

The average annual growth rates between the stages are 26.6, 28.9, 10.9 and 12.9 per cent respectively. Thus we see that although landings have increased over the stages, the growth rate has declined. The maximum growth rate between S2 and S3 of 28.9% may be attributed to intensification of mechanisation. This promising growth rate did not sustain over the stages and suffered a decline in the later stages inspite of introduction of purse seiners, motorisation of indigenous craft and increase in the overall effort. This may be attributed to the fact that the area of exploitation remained more or less the same inspite of the technological changes in the capture techniques. For the purpose of this paper, the area of exploitation along the coast has been divided into 4 regions

namely, North east (West Bengal and Orissa), South east (Andhra Pradesh, Tamil Nadu and Pondicherry), South West (Kerala, Karnataka and Goa) and North west (Maharashtra and Gujarat). The landings in the Andaman Nicobar Islands and the Lakshadweep have not been considered, as the aforementioned regions contribute more than 99% of the marine fish landings in India. The average annual landings in the regions, during the five stages and their percentage contribution to the country's landings are given below.

Stagewise average annual landings in the four regions

(Figs in tonnes)

Stage	N.E	S.E.	S.W.	N.W.
S1	10320	182152	319319	219212
%	1.4	24.8	43.4	29.8
S2	22642	225466	437500	233294
%	2.4	24.2	47.0	25.0
S3	25590	304315	523299	344455
%	2.1	25.3	43.6	28.7
S4	47489	339372	476633	485011
%	3.6	25.5	35.8	34.9
S5	68493	384231	512941	526699
%	4.6	25.6	34.1	35.1

(% : denotes per centage contribution of the region to the average all India landings during the stage.

It is obvious from the above table that although the absolute landings have been gradually increasing over the stages, the rate of growth has however, has been declining. It is also seen from the above table that the relative contribution of N. W. regions have increased whereas that of the South east region remained more or less constant. The trends in the landings of the some of major resources are described below.

Elasmobranchs

There is no directed fishery to exploit this group comprising sharks, rays and skates. The landings (TABLE 1) ranged from about 29,000 tonnes in 1967 to about 70,000 tonnes in 1983. Although there has been an increase

TABLE

Estimated landings (in tonnes) of major exploited

Year	Elasmo-branch	Catfish	Oil Sardine	Other Sardines	Anchovies	Bombay duck	Perches	Croakers	Ribbon fish
1961	33554	10928	167884	19764	22103	93844	15377	29917	19515
1962	40761	19327	110299	19551	19168	83933	8958	32439	20586
1963	42997	17567	63647	27173	28672	91670	8797	22570	16452
1964	34890	22729	274333	40398	25179	81342	12563	25197	25891
1965	32054	18915	261863	42770	24377	73894	8544	23673	41921
1966	37469	22572	247214	64643	26679	77363	12138	26032	45124
1967	29401	24290	256324	34980	29237	74882	8337	25458	27463
1968	31028	23748	301446	41740	18355	82407	8810	26142	25586
1969	35442	26903	174249	52467	31436	76276	12865	35041	31722
1980	44048	50631	226997	55220	24400	78443	13913	41903	26984
1971	41348	48858	209261	61283	19516	71508	12993	36903	44690
1972	46237	42443	127568	43629	18699	51570	15247	40159	36225
1973	44917	52642	144395	108523	25394	64345	21513	87682	53106
1974	66054	76196	126676	83921	41507	61138	36837	79261	63028
1975	65230	68689	159240	112117	30744	99614	35232	114535	57330
1976	54605	43540	169262	10000	30069	87075	18162	87581	64542
1977	62216	53504	150130	65724	34033	85236	31799	99887	42407
1978	61621	39231	168078	52838	39054	125481	49312	96379	77795
1979	52843	48817	153971	68351	26588	126044	35657	93018	71349
1980	57862	43745	115744	67053	33684	95505	38541	89360	62690
1981	56009	59390	220126	61980	33383	137790	31325	82686	41569
1982	64316	67664	205294	55496	41824	86476	45026	87247	48875
1983	70046	60764	183706	77010	89257	100950	56141	100755	39071
1984	57757	57415	188832	67594	74951	117742	71241	109852	53085
1985	52804	44500	120587	60773	54514	112454	71813	101078	84403

in the landings compared to the early sixties, at present there are indications of stabilisation in the magnitude of landings. These groups are mainly caught in hooks & lines, Drift/gill nets and trawl nets. The regionwise and stagewise elasmobranch landings are given in the following table.

Elasmobranch landings (tonnes)

Stages	N.E	S.E.	S.W	N.W.
S1	272	17,842	8,650	9,903
S2	469	17,641	7,926	8,928
S3	1,022	25,938	11,161	14,342
S4	3,434	23,075	10,616	20,326
S5	2,800	21,614	10,626	24,610

Marine fish resources in India during 1961-85

Caran- gids	Silver bellies	Pom- fret	Mack- erel	Seer- fish	Tun- nies	Penaeid prawns	Non- Penaeid prawns		
26511	15763	16488	34485	1449	7805	39083	23685	94	683569
11859	18104	25678	29103	10941	2297	48251	24884	96	644244
20939	17748	17256	76980	9116	4454	41071	40522	260	655484
29830	28301	19580	23863	11160	5002	63389	31506	463	859582
21072	27147	17892	43095	9436	3698	38085	41415	265	832777
23635	37972	17845	31959	10113	3063	56146	34768	964	890311
27797	43769	27460	29194	9854	3370	62475	31033	521	862631
19584	36385	27798	20785	12759	3309	68346	31586	1517	902948
24560	44038	24176	91837	11516	3445	72133	33964	769	913630
22413	49275	17589	139206	13410	3015	89857	31834	1184	1085607
23428	32510	21000	204575	18339	6032	72109	76734	1505	1161389
30886	32314	19007	108971	21210	5760	78361	85488	1026	980049
29200	48127	22052	79423	19700	5678	136514	66955	1394	1220240
23841	50902	22421	37462	19841	10839	114934	65244	3677	1217797
24238	39813	24987	45947	18897	11285	141713	79038	7889	1422693
31318	42445	37701	65497	20159	19322	114640	76787	10826	1352855
35739	34504	35127	62136	21119	13005	96472	73992	10005	1259782
21476	41777	41434	85233	20779	13893	129204	50652	15931	1403607
33935	55255	40427	71514	29547	26595	113665	63917	15032	1388380
30113	54400	38231	55279	25986	20371	112037	58700	11335	1249837
37345	69449	48728	48660	27553	17803	83539	61430	9548	1378457
40025	72668	49968	28007	33197	20597	110797	51148	15799	1420624
53082	91733	54290	31227	35815	16959	118203	43750	19748	1548475
58813	57122	49979	42648	36615	20354	130051	61961	20964	1630678
54704	52725	32974	61860	34078	31261	121958	67084	31586	1534726

It is observed from the above table that during the initial stages (S1 and S4) the landings were of more or less the same magnitude. Then there was a sudden spurt in the landings during which the process of mechanisation got established in all the regions. After this, in spite of increase in effort, the

landings showed a declining trend in the south east region, the major contributor to the elasmobranch landings in the country. In the south west region the landings seem to be stabilised. However, in the north west region, the landings are showing an increasing trend. In the north east region, no definite trend is discernible.

Catfish

The catfish landings (Table 1) ranged from about 11,000 tonnes in 1961 to about 76,000 tonnes in 1974. The fishery is supported by many species and are caught in variety of gears, namely, drift/gill net, hook & lines, trawls, purse seines, dolnet etc. The region-wise and stage-wise landings are given in the following table.

Landings of catfish (Tonnes)

Stages	N.E.	S.E.	S.W.	N.W.
S1	263	7,329	3,043	6,848
S2	254	8,006	12,034	9,063
S3	1,198	16,753	25,164	14,637
S4	2,051	11,373	17,563	14,764
S5	8,938	8,551	18,006	22,359

In the north east region there were two sudden spurts in the landings, from S2 to S3 and from S4 to S5. In the south east region the spurt in the landings in the third stage did not last long and there was a gradual and inexplicable decline in the landings. In the South west region where the process of mechanisation began much earlier, the spurt in the landing occurred in the second stage itself and the landings in subsequent stage were also higher. After this, there was a sudden fall during S4 and the magnitude of landings remained more or less the same in the fifth stage also. In the north west region there is a gradual increase in the landings.

Oil sardine:

Oil sardine the major component of marine fish landings in India forms a major fishery in the South west region especially in Kerala and Karnataka. At present the fishery is gaining importance in the South east region namely along the Tamil Nadu and Pondicherry coast. The landings during 1961-85 are given in Table-1. The feature of the landings is characterised by its wide and wild fluctuations over the years. The major gears employed for exploitation are the boat seines, gill nets, rampans, shore seines and of late purse seines. With the advent of purse seine, rampans, the major gear along

the Karnataka coast were adversely affected. The oil sardine landings in India ranged from 1.1 lakh tonnes in 1962 to 3 lakh tonnes in 1968 and its percentage contribution varied from 8% in 1985 to 33.4% in 1968. The stage wise landings in the south east and south west regions are given below.

Oil sardine landings (tonnes)

Stage	S.E.	S.W.
S1	34	1,73,423
S2	121	2,40,787
S3	211	1,51,355
S4	439	1,50,366
S5	1,878	1,81,042

It is evident from the above table, oil sardine has been gradually gaining importance in the south east region, where as in the South west region the landings exhibited the typical fluctuating nature.

Other sardine

This group consists of other *Sardinella* spp. other than the *sardinella longiceps*, the oil sardine. The landings during 1961-85 are presented in the Table 1. Like the oil sardines the landings fluctuated over the years and of late there are indications of declining trend. The landings ranged from about 29,500 tonnes in 1962 to 112,000 tonnes in 1975 and its contribution ranged from 3% in 1962 to 9% in 1973 to the total marine fish landings. As the contribution by the north west region is negligible, the landings in different stages in the other regions are given in the following table.

Landings of the other sardines (tonnes)

Stage	N.E.	S.E.	S.W.
S1	1536	16,615	11,175
S2	2896	31,185	10,766
S3	1644	46,194	31,683
S4	1999	41,321	26,114
S5	4248	46,675	12,139

From the above table we observe that in the order of abundance south east region ranks first followed by the south west and north east regions. In the north east region highest

andings were recorded in the fifth stage, which is also the case with the south east region. In the south west region the average landings have declined after the third stage.

Anchovies

The landings of anchovies comprising *Stolephorus* spp. during 1961-85 (Table-1) ranged from about 18,000 in 1968 to about 89,000 tonnes in 1983, the percentage contribution ranging from 2 to 6. The anchovies are mainly caught in the traditional seine nets and of late very large quantities are caught in the purse seines. They are quite abundant in the south east and the south west regions. They are also available in the other regions but form a negligible proportion. The stage wise landings in the south east and south west regions are given in the following table.

Landings of Anchovies (in tonnes)

Stage	S.E.	S.W.
S1	15,349	7434
S2	15,910	9178
S3	13,661	12,442
S4	18,981	12,779
S5	17,530	39543

The variations in the landings in the south east regions are less over the stages as compared to those in the south west region. In the south west region the landings have gradually increased and experienced a sudden increase in the fifth stage. This can be attributed to good landings by the purse seines.

Bombay duck

The Bombay duck landings in India during the period under study are given in Table-1. This forms an important component in the north west region comprising Maharashtra and Gujarat. This fishery is supported by a single species *Harpodon nehereus* and mainly caught in the dol nets. Like the oil sardine, the bombay duck landings have also shown wide variations over the years. Ranging from about 52,000 tonnes in 1962 to about 138000 tonnes in 1981, in which year Maharashtra recorded all time high landings of about 82,000 tonnes. An interesting pattern in the landings was that the landings in

Gujarat were higher than the Maharashtra upto 1972 and from 1973 onwards the latter recorded higher landings till now. It is also observed that the percentage contribution of Bombay duck in the marine fish landings of the Gujarat state which was as high as 65% in the early sixties has gradually declined and now forms only about 20% of the total fish landings in the state. Besides, the north west region, the Bombay duck landings are also recorded in the north east region, though not in such abundance as in the north west region. The stage wise landings in these two regions are presented below.

Landings of Bombay duck (in tonnes)

State	N.E.	N.W.
S1	275	84,100
S2	1,175	76,189
S3	1,662	67,527
S4	1,524	1,01,585
S5	2,248	1,07,816

In the north east region we observe that there is a general increasing trend. In the north west region the landings showed a gradual decline from the first stage to the third stage. This was mainly due to gradual reduction in the landings along the Gujarat coast. In the beginning of the fourth stage the landings in Gujarat improved which along with the continuing increasing trend in Maharashtra landings during this period resulted in higher average landings during the 4th stage. In the 5th stage the landings increased on an average by 6% inspite of record high landings in Maharashtra during 1981.

Perches

This group comprises rock cods, snappers, pig face breams, threadfin breams and other perches. Among these, the threadfin breams and pig face breams dominate the total perch landings. The total landings (Table 1) of this group, in general, have been increasing over the years with a minimum landings of about 8000 tonnes in 1967 to about 72,000 tonnes in 1985. This is mainly caught in trawlnets and other traditional seine nets. But with enhancement of effort by the mechanised sector especially the trawlers the perches formed on important

component of trawler landings. The regionwise, stage wise landings are given below.

Landings of perches (in tonnes)

Stage	N. E.	S. E.	S. W.	N. W.
S1	74	6,588	1,172	2,929
S2	19	6,943	2,406	1,736
S3	103	9,364	10,685	3,985
S4	198	10,556	17,133	6,355
S5	934	20,777	20,643	11,740

It is seen from the above table that there is a good improvement in the landings over the stages. In the south west region the sudden spurt in the landings in the third stage coincided with intensification and concentration of mechanised effort. After this, the landings gradually increased over the stages. The south west region which ranked second to the south east region in respect of landings upto the second stage has become the major contributor from the third stage onwards. The general increasing trend was also noticed in the other regions also. This is among the few marine fishery resources showing an increasing trend in all the regions.

Croakers

There has been a substantial increase in the landings (Table 1) from the early fifties to the mid seventies after which the landings seem to be stabilised till the mid eighties. The minimum landings were about 22,000 tonnes in 1963 and the maximum was about 114,000 tonnes in 1975. The major gears are trawl and gill nets. The region wise landings over the five stages are given below.

Landings of Croakers (in tonnes)

Stage	N.E.	S.E.	S.W.	N.W.
S1	721	9,380	5,008	11,797
S2	1,269	12,569	5,585	11,373
S3	2,535	17,847	12,405	38,921
S4	4,398	24,747	13,723	50,376
S5	11,448	22,717	10,761	51,126

In the northwest region, the landings suddenly shot up during the third stage. This sudden increase was due to heavy landings along the Gujarat coast. The landings along this coast

which were about 4000 tonnes in 1972 rose to about 40,000 tonnes in 1973. This group which showed a promising trend upto the fourth stage could not sustain its increasing trend and seemed to have more or less stabilised in all the regions except in the north east region.

Ribbonfish

Compared to the early sixties, the magnitude of the landings (Table-1) have considerably increased but later on began fluctuating during the late seventies and early eighties. The landings ranged from about 16,000 tonnes in 1963 to about 84,000 tonnes in 1985, the highest during the twenty five year period. The main gears in which they are caught are the boat seines and shore seines. They are also caught in the dol nets, trawl and gill nets. As the north east region does not contribute significantly to the landings, the catches in the other regions over the stages are given below, these three together accounting for more than 95% of the ribbon fish landings in the country,

Ribbon fish landings (tonnes)

Stage	S,E,	S,W,	N,W,
S1	15,060	4202	4891
S2	15,590	8,567	6,575
S3	19,393	19,878	10,793
S4	26,142	17,124	19,627
S5	15,266	12,244	22,546

During the first two stages more than half of the ribbonfish landings in the country was accounted by the south east region. After this the landings in this region began fluctuating. In the South west region, the third stage recorded higher landings and thereafter the landings started to decline. However, unlike these two regions, the north west region has witnessed a steady increase in the landings and during the fifth stage it out-scored the other two regions.

Carangids

This group comprises horse mackerel, scads, leather jackets and the other carangids. The landings (Table-1) ranged from about 20,000 tonnes in 1968 to about 59,000 tonnes

in 1984. Its percentage contribution to the all India marine fish landings ranged from 2 to 4. The landings of this group in general, have shown an increasing trend over the period under study. Bulk of the landings in India are accounted by the south east, south west and north west regions. The landings during the five stages are given below.

Carangids landings (tonnes)

Stage	S.E.	S.W.	N.W.
S1	13,824	6,652	1,383
S2	12,524	7,100	3,370
S3	12,437	11,121	2,984
S4	12,517	13,533	3,451
S5	20,655	18,346	7,480

In the south east region, the landing were of the same magnitude during the first four stages and improved in the fifth stage. A similar trend was observed in the north west region also. However, in the south west region the landings have been gradually increasing. This was mainly due to increased landings in Kerala, Karnataka and Goa in the early eighties.

Silverbellies

Silverbellies are more abundant in the South east region especially along the Tamil Nadu coast. They are mainly caught in the trawl nets and the seine nets, bulk of the landings beings accounted by the trawl nets. The landings (Table 1) ranged from 16,000 tonnes in 1961 to about 92,000 tonnes in 1983 and it accounted for 2 to 6 % of the total marine fish landings during the period. About 95% of the silver bellies landings are accounted by the south east region and the south west region. The silverbellies landings in these regions during the five stages are given below.

Landings of Silverbellies (in tonnes)

Stage	S.E.	S.W.
S1	12,167	8,266
S2	26,087	13,828
S3	26,673	13,100
S4	36,237	8,415
S5	56,408	10,422

While the landings in the south west region fluctuated, the landings in the south east region gradually increased over the stages and the contribution of the south east region which was about 56.8% during the first stage increased to 82.1% during the fifth stage.

Pomfrets

The landings of pomfrets (Table-1) ranged from about 16,000 tonnes in 1961 to about 54,000 tonnes in 1983 and it accounted for 2 to 4% of total landings in the country. This group comprises silver, black and chinese of which silver pomfrets dominated the landings. The landings in country over the years have shown general increasing trend. The landings in the four regions over the stages are given below. The main gears employed are dilt/grill net and purse seines pomfrets are also caught in trawl and dol nets.

Pomfret landings (tonnes)

Stage	N.E.	S.E.	S.W.	N.W.
S1	243	4,497	27.82	11,819
S2	399	4,273	2,003	16,259
S3	1,124	5,348	2,454	12,959
S4	7,893	3,625	2,687	24,337
S5	6,141	5,948	4,220	30,947

In the north east region, the landings exhibited a sudden spurt during the fourth stage and there was a decline during the fifth stage. In the south east region the landings were more or less stable. In the south west region the landings were more or less of the same magnitude up to the fourth stage and have suddenly improved during the fifth stage. In the north west region however, there was a steady increase from the third stage.

Mackerel

Mackerel, another important marine fish resource, has shown wide and wild fluctuations (Table-1) ranging from about 21,000 tonnes in 1968 to 2,05,000 tonnes in 1971. It is mainly caught in boat seines, gill nets and of late purse seines accounted for higher landings in south west region especially along the Karnataka and Goa coasts. The south west and south east region account for

more than 95% of the mackerel landings in India. Although Ratnagiri coast of the north west region also recorded landings, its contribution is only marginal. The mackerel landings in the south east and south west regions over the stages are given below:

Mackerel landings (tonnes)

Stage	S.E.	S.W.
S1	4,253	34,369
S2	4,546	45,884
S3	10,393	81,242
S4	9,175	57,266
S5	10,737	29,858

In the south east region the landings have improved after the second stage and remained more or less of the same magnitude during third to fifth stage. However, in the south west region the landings have gradually declined from the third stage. Of late there are indications of good mackerel fishery in the south east region especially along the Andhra coast. In spite of introduction of the purse seines on the south west region especially more so along the Karnataka coast, there has not been any improvement in the landings.

Seerfishes

The landings of seerfish from 1961-85 are presented in the Table 1. They ranged from about 9000 tonnes in 1963 to about 37,000 tonnes in 1984. The species which dominate the landings are *S. commerson*, *S. guttatus* *S. lineolatus* and *Acanthocybium* spp. They are caught by gill nets, driftnet and hooks and lines. The regionwise landings over the different stages are given below. More than 95% of the seer fish landings in India is accounted by the south east, south west and north west regions and of these south east dominates the landings.

Seerfish landings (tonnes)

Stage	S.E.	S.W.	N.W.
S1	6,491	2,184	1,481
S2	6,041	2,539	2,405
S3	9,854	4,842	4,140
S4	9,081	6,808	5,980
S5	10,686	10,243	9,277

It is observed from the above table that except in the south east region, in the other regions the landings have been gradually increasing. In the south east region, however, the landings seem to get stabilized from the third stage. The relative contribution of the south east region to the all India seerfish landings has been gradually declining from about 62% during the first stage to about 32% in the fifth stage. Whereas in the other two regions their relative contribution have been gradually increasing.

Tuna

The landings of the tuna (Table 1) ranged from about 2000 tonnes in 1962 to about 31,000 tonnes in 1985. In general, the landings have shown an increasing trend. In all the regions the coastal species such as *Euthynnus affinis*, *Auxis* spp. dominate the landings although the oceanic species *Katsuwonus pelamis* and *Thunnus* spp. are also represented to a little extent in the landings. The north east region contributes only marginal quantities to the total tuna landings in India. The landings in the other regions over the five stages are given below

Tuna landings (tonnes)

Stage	S.E.	S.W.	N.W.
S1	1,785	2,227	210
S2	1,168	1,406	352
S3	1,621	4,504	655
S4	3,349	11,629	1,679
S5	3,573	9,164	5,052

The common gear employed in all these regions is the drift/gill net and in the south west region purse seines also land good quantities of tuna. The sudden increase in the landings from the third stage, in south west may be attributed to increase in the effort of mechanised gill netters and the purse seiners. The increase in south east region may be attributed to the higher landings along the Tamil Nadu coast especially in the Tuticorin area where seasonal tuna fishery with mechanised gill netters gained importance.

Penaeid prawns

This group is by far most important and sought after marine fishery resource, because

of its high export value. It sustains the trawl fishery and comprises many species. The landings of this group are given in Table 1. From this, it is observed that there are indications of stabilisation of the landings. The landings ranged from about 29,000 tonnes in 1961 to about 142,000 tonnes in 1976. Its contribution to the country's total landings ranged from 5.7% in 1961 to 11.2% in 1974. Perhaps this is the only variety of marine fish resources towards which there is a directed fishery and it gained considerable importance from the early seventies. The landings over the stages in the four regions are given below.

Penaeid prawn landings (tonnes)

Stage	N.E.	S.E.	S.W.	N.W.
S1	2,403	6,119	25,824	11,439
S2	5,825	11,019	35,600	17,799
S3	2,138	14,475	66,054	26,041
S4	2,411	17,727	47,020	45,798
S5	2,772	22,752	38,493	48,826

The prawn landings were maximum in the south west region upto the fourth stage. At the third stage the landings were high in south west region and later on there was a gradual decline in spite of increased effort. However in the south east region and the north west region the landings are an average increased over the stages. In the north west region the rate of increase has considerably declined giving indications of plateau in the landings. The north east region, is the only region where the landings on an average except during the second stage have remained more or less the same. This is due to the fact that the number of trawler operations are less compared to the other regions.

Non penaeid prawns

The Annual landings (Table-1) ranged from about 24,000 tonnes in 1961 to about 85,000 tonnes in 1972. They are mainly caught in dol nets. They are quite abundant in the north west region mainly along the Maharashtra coast. They are also available in the south east region especially along the Andhra coast. There are indications of decline in the landings and this is mainly due to

declined landings in the Maharashtra coast. The north west region and the south east region together account for about 98% of the country's non penaeid prawn landings. The stage wise landings are given in the following table.

Non-penaeid prawn landings (in tonnes)

Stage	S.E.	N.W.
S1	965	31,406
S2	1,623	30,924
S3	1,978	68,809
S4	3,864	59,608
S5	3,510	50,681

It is evident from the above table that during the initial stages of mechanisation the landings in the north west region were more or less of same order. During the third stage when the mechanisation was intensified, the landings increased. After this in spite of increase in the mechanisation the landings did not respond positively to the increased effort. This phenomenon in the north west region is mainly due to reduction in the coastal district of Thane in Maharashtra. In the south east however the landings increased upto the fourth stage and got stabilized in the fifth stage.

Cephalopods

This group comprises squids, cuttle fish and octopus. The landings of this group (Table-1) ranged from a meagre 90 tonnes in 1961 to about 32,000 tonnes in 1985. Initially these were either discarded or not recorded. But of late because of the export value they were retained on board and hence the landings seem to show increasing trend. They are mainly caught in the trawls and hooks and lines. The south west and north west region account far more than 75 % of the cephalopod landings in the country. The region wise landings over the stages are given below.

Stage	S.W.	N.W.
S1	152	33
S2	508	121
S3	1,408	511
S4	5,192	5,459
S5	4,943	10,093

In both the regions, the landings improved considerably. However in the south west region the landings seem to get stabilized with more or less the same magnitude during the fourth and the fifth stage. In the north west region however there is gradual increase and this region has outscored the south west region from the fourth stage onwards. This increasing trend is also reflected in the all India cephalopod landings.

Potential yield

The foregoing sections have given an idea of the present exploitation pattern of some of the major fishery resources currently exploited in the four regions. In this section potential yield that could be obtained from the regions are indicated. These estimates pertain mostly to the 0-50 m depth zone and do not include the island territories.

Many attempts have been made in the past to assess the potential yield from the Indian waters. These estimates ranged from 2 million tonnes to 8.5 million tonnes per annum. (Sudhramanyam 1959, Panikker, 1966, Prasad *et al.*, 1970, Cushing 1977, Gulland, 1971 Jones and Banerji 1973, Prasad and Nair 1973, Shomura, 1976, George *et al.*, 1977 and Silas *et al.* 1976). Recently, Alagaraja (1987) has estimated the potential yield of 3 million tonnes from 0-200 m depth of which 2 million tonnes obtainable from the 0-50 m depth. It is assumed that the potential yield is the maximum average yield that could be exploited. In this paper an attempt is made to estimate the potential yield from the average annual yield during the different stages. The average annual landings during the five stages are given below.

Stage	S1	S2	S3	S4	S5
Landings	7.35	9.31	12.00	13.31	15.03

(lakh tonnes)

From the trend of the landings over the five stages, it appears that the marine fish landings seem to follow the Gompertz growth formula. The fit of the above data to the Gompertz curve resulted in asymptotic (C_{∞}) value of 20.92 lakh tonnes for the annual landings, which can be taken as an estimate of the potential harvestable yield.

Following the same analysis the potential yields for the four regions are given below.

Region	Potential yield (lakh tonnes)	Remarks
North east	1.20	Data from stages S_3 to S_6 only
South east	5.85	Data from stages S_1 to S_6
South west	6.00	**
North west	6.90	Data from stages S_2 - S_6
	19.95	

(** as the data did not follow any growth pattern, the maximum catch during the 25 year period is taken as an estimate of the potential yield. The above estimates pertain to the 0-50m depth zone only.)

The above estimate does not include the Island territories of Lakshadweep and Andaman and Nicobar. As 99% of the landings from the 0-50m depth zone in India is accounted, by the four regions, the potential yield that could be harvested from the 0-50m depth zone in the Indian waters is given by $\frac{100}{99} \times 19.95 = 20.15$ lakh tonnes.

This estimate agrees closely with the one obtained above. It is also interesting to note the above estimates agree closely with an estimate of 20.22 lakh tonnes by Alagaraja (*op cit*) and 22.60 lakh tonnes by George *et al.* (*Op. cit*).

CONCLUSIONS

From the foregoing the following observations are made. The rate of growth in marine fish landings has decreased and any further increase in effort may not result in higher landings, in the presently exploited area.

Among the four regions, the north east, south east and the north west regions show promise of higher landings.

Among the pelagic resources, anchovies, carangids, ribbonfish and coastal tunas promise higher yields if suitable modifications in the capture techniques are made. The trend of cat fish landings indicate the potentials of the resource along the north east coast and north west coast.

Among the perches, the threadfin breams are the most abundant group having good potential on both the coasts.

The cephalopods which recently have realized higher export value are expected to be harvested in larger quantities especially from the north west and the south west regions.

The potential yield from 0-50 m is estimated to be in the range of 20-21 lakh tonnes. The estimate of potential yield from 51-200 m has been estimated at 10 lakh tonnes (Alagaraja, *op. cit.*).

To increase the catches of the larger pelagic fish such as coastal tunas, seerfish, pomfrets etc. from the traditional fishing grounds it is suggested that the currently employed country craft be motorized.

Proper fishing regulatory measures have to be taken to control over-fishing (both biological and economic) by implementing mesh regulations and demarcation of areas of exploitation by the different types of gear.

Adequate infrastructure facilities such as berthing, handling, storage, ice production and marketing need to be developed for the sustained growth of marine fisheries.

ACKNOWLEDGEMENT

The author wishes to express his gratitude to Dr. P. S. B. R. James, Director, CMFRI for his constant guidance and the encouragement for preparation of the paper.

REFERENCES

ALAGARAJA, K. 1987 A brief appraisal of marine fisheries in India. The paper presented in the National Symposium on Research and Development in Marine Fisheries held at Mandapam, 16-18 Sept., 1987.

CUSHING, D. H. 1971 Survey of resources of the Indian Ocean and Indonesian area. *IOFC/DEV/71/2*. FAO, Rome: 123 pp.

GEORGE P. C. 1977 Fishery resources of the Indian Economic zone. *Souvenir, Silver jubilee, I. F. P., Cochin, India*, 79-116.

GULLAND, J. A. 1971 The fish resources of the ocean. *Fishing News (Books) Ltd.* England. 255 pp.

JONES, S. and BANERJI S. K. 1973 A review of the living resources of the Central Indian ocean. *Proc. Symp. Living Resources of seas around India, C.M.F.R.I.*: 1-17.

PANIKKAR, N. K. 1966 Fishery resources of the Indian Ocean. *Curr. Sci.* 35 (18): 451-455.

PRASAD, R. R. *et al.* 1970 A quantitative assesment of the potential fishery resources of the Indian Ocean and adjacent seas. *Indian J. Anim. Sci.* 40 (1): 73-98.

PRASAD R. R. and NAIR, P.V.R. 1973 India and the Indian Ocean fisheries, *J. Mar. Biol. Ass. India.* 15 (1):1-19.

SILAS, E. G. *et al.* 1976 Exploited marine fishery resources of India, a synoptic survey with comments on potential resources. *Bulletin No. 27 CMFRI*: 25 pp.

SHOMURA, R. S. 1976 Indian Ocean coastal waters. *FAO Fish Tech. Pap.* 97: 425 pp.

SUBRAMANYAN, R. 1956 Studies on the phytoplankton of the West Coast of India. *Proc. Indian Acad. Sci.* 50 (B): 113-187.

CATCH RATES AND CATCH COMPOSITION OF FISH IN THE WEDGE BANK IN COMMERCIAL FISHING

G. N. Mitra
Professor Para, Cuttack-753003

ABSTRACT

The paper embodies some of the un-published results of commercial fishing in the Wedge Bank located south of Cape Comorin between a Long of 77° and 78°. 10'. The area is approximately 4000 Sq. miles exposed to full force of both the SW and NE monsoons. The continental shelf off Cape Comorin has a gentle slope up to 100 Metres beyond which the depth sharply increases. Bottom is of coarse yellow sand overlying flat rock up to 60 m contour. Beyond this the bottom is firm clear sand with stretches of flat rock. There are rough patches of pinnacle rocks. Commercial large fishes consist mainly of rock fishes (47.8 to 65%) and carangids (2.4 to 11.9 %). Catch per hour of comparable trawlers of 450 to 650 HP has been estimated after adjusted effort.

Year	Catch effort in Hours	CPUE Kg/Hr.
1966-66	3652	243.6
1966-67	5791	173.1
1967-68	2834	136.3
1968-69	3412	190.9
1969-70	1924	154.0

Average seasonal catch was 183 Kg/Hr in Nov-April and 282.9 Kg/Hr in May to Oct.

In more recent operations by paired trawlers of 1100 HP 36 M OAL chartered from abroad the catch rate in 1983 has been 247.28 Kg/Hr in operation of 358 hours. Squids and cuttle fish catch varied between 26 to 79% in August and September. Details have been presented in the paper.

INTRODUCTION

The area of the sea south of Cape Comorin has been generally known as the 'Wedge Bank'. The area has been defined by the Fishery Survey of India (F. S. I) as that part of the sea bed between 76°. 30'E to 78°.00 E Long, and 07°.00,N to 8°. 20' N Lat. The area is about 4000 Sq. miles. The general map of the Bank with contour lines may be seen in Fig. 1.

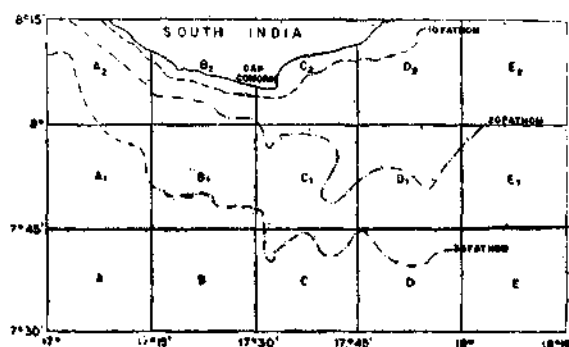

Fig. 1 Depth contours of Wedge Bank

Operations of different vessels in the Bank have been evaluated in this paper.

Trawlers operated in the Bank

Commercial fishing was first commenced in 1928. 'Tongkol' (125' OAL, 99 NPH) operated in 1928 and 1929 and 'Bul Bul' a vessel of the same type from 1928 to 1935. The total annual catch during this period varied from 106 to 597 tonnes. The catch per day's absence from port varied between 1128 and 2512 kg/hr. The number of days fished per year was between 96 and 262.

These vessels did not give an economic return and after a break of 10 years, fishing was resumed as below.

'Reglan Castle'	::	126' OAL 87 NHP
		1945-1951
'Aringa'	::	147 Do 450 BHP
		1947-1948

'Brancoglen' :: 149 Do 91 NHP
1951 to 1963
'Maple Leaf' :: 143 Do 84 NHP
1953 to 1970

'Gandara', 'Pesalai', 'Beruwala' 'Megamuwa' 'My Liddy' were of the same type and HP with OAL of 33 to 36 m OAL. These operated from 1965 onwards. Records have been available to the author up to part of 1970.

Many of the vessels were under foreign skippers and operated the standard Granton Trawl. In operations in the field it was found that the net was too heavy and with replacement with the lighter 'Engel' trawl catches improved between 25 to 50%. Chartered vessels of 1100 HP operated for a short period in 1983 using paired trawls.

Nature of Fishing grounds

Not all of the bank is trawlable as parts of the ground are rocky. Some of this can be trawled with rollers or bobbins in the ground rope. The bottom is coarse yellow sand overlying flat rock to the 60 m contour. Beyond this and up to the edge of the continental shelf the bottom is made of firm, clear sand with stretches of flat rock. There are a few rough patches of pinnacle rocks in both shallow and deep water and also very limited areas of bottom of mud. Some areas had profuse growth of sea fans (gorgonids) and sponges which interfered with trawling and sorting of catches. Over the years, due to continuous trawling operations these more or less disappeared from the fishing areas.

Hydrography and weather

The Bank is exposed to the full force both of NW and SW Monsoons. Foreign skippers consider that weather conditions are more favourable to fishing in the bank than in European waters. Except for 2 or 3 months, the rest of the period has a ground swell. During Monsoons the wind speed is 3 to 6 Beaufort scale with a current of 0.5 to 0.1 knot per hour.

Catch per hour in kg. by different vessels

Table 1 gives the details of catches, hours fishes and CPUE (kg/hr). In the season Nov-

TABLE - 1.

Effort, catch and CPUE of Ceylonese commercial vessels in Wadge Bank

Vessel	Catch (Tonnes)	Hours (Effort)	CPUE (Kg/hr)	Years & season
				NOV-APR
B & M	3942	11093	281.4	1957-63
M	332	1706	194.6	1963-65
Vessels	3172	24595	128.9	1965-1970
G	141	1017	138.6	1964-65
Total	7587	38411	197.5	
MAY-OCT				
B & M	3411	10013	340.6	1957-63
M	795	2837	280.2	1963-65
Vessels	5008	25779	194.2	1965-70
G	249	1141	218.2	1964-65
Av. per year	4827	—	309.0	
Total			39770	
Legend	B . . Brancoglen			
	M . . Maple Leaf			
	G . . Gandara			
	Combined . . same type vessels			

April the CPUE has varied between 138.6 and 281.4 kg/hr the general average being 197.5 kg/hr. But in the season May to October the variation is between 194.2 and 340.6 kg/hr the average being 309 kg/hr. It is known that both rock fishes and carangids migrate to the bank during May-Oct. Catch rates were taken of selective vessels for 1965-1970. The results are given below.

Year	CPUE Kg/Hr.	Effort (Hrs)
1965-66	243.6	3662
1966-67	173.1	5791
1967-68	136.3	2834
1968-69	190.9	3412
1969-70	164.0	1924

Average seasonal catch was 183 kg/hr in November to April and 282.9 kg/hr in May to Oct. Chartered vessels sampled the Wadge Bank in Aug/Sept 1983 for 358 hours between the depths of 40 and 80 m. The catch rate was 247.29 kg/hr.

Commercial grouping of fishes

The following grouping is made in analysing the commercial catches.

Rock fish or Mullets (Large) Lethrinus nebulosus (Forsk.) *L. mahsenoides* (Val) *Lethrinella miniata* (Schneider) *Spilotichthys pictus* (Thunberg), *Epinephelus undulosus* (Quoy and Gaimard), *Pristipomoides typus* (Bleeker), *Lutianus sanguineus* (Cuvier), *L. utjanus* sp. etc.

Carangids

Gnathanodon speciosus (Forsk.), *Caranx chrysophrys* (Bloch) *C. malabaricus* (Bloch & Schneider), *Caranx carangus* (Bloch) etc. Catfish *Tachysurus thalassinus* (Ruppel), *Carcharhinus sorrah* (Cuvier), *C. maclovi* (Muller & Henle) etc.

Information available on the bionomics of the commercial species orientated to capture is sketchy although most of the fish taken in the coastal waters of Ceylon have been found to have ripe gonads. Most of the species are common to the coastal belt of the Indian peninsula.

Variation in the catch composition

The annual variation from year to year in the percentage composition of the catch of the groups is not much except in case of carangids. Finer analysis according to species is not available. Table below shows the annual variation in percentage of groups.

Groups	1966	1967	1968	1969
Rockfish	52.6	53.3	47.8	65.4
Carangids	11.9	6.4	7.9	2.4
Sharks & Skates	9.3	7.5	5.3	4.5
Catfishes	11.6	21.5	21.4	12.8
Others	14.6	11.4	17.6	14.9

Percentage composition in Chartered Vessel catch.

Table below shows the variations in the percentage composition of the catch in day and night fishing by chartered vessels.

Group	Day	Night
Snapper	10.96	12.25
Squid	29.80	2.88
Cuttle fish	28.12	54.04
Seer	.02	Nil
Carangids	.75	Nil
Perches	4.40	3.61
Misc. Big	3.95	4.32
Misc.	22.00	22.90

Survey by FSI

Valuable knowledge has been gained by the operations of Matsya Neerikshani, a modern trawler which has conducted sample fishing in all depths of the Bank. Average catch rate has been 130 kg/hr between depth of 40 and 80m. The commercial projection is 260 kg/hr.

DISCUSSION

Wadge Bank is considered to be a good fishing ground with a sizable percentage of quality fish, but the fishing by Sri Lanka and some other countries has not been very viable commercially. The Chartered Vessels after sampling Wadge Bank all veered to Kori Great Bank which has given better fishing. It appears that the lean season i. e. April to Nov. does not give an economic earning. Use of vessels with less HP and lighter nets giving the same catch rates of the vessels operated by Ceylon is likely to prove profitable. It may also be possible to introduce smaller vessels for specially squid jigging. Research support is not adequate to strengthen the economics of commercial fishing. This is particularly necessary in studying the oceanographical causes of migration and improvement and diversification of craft and gear. There seems to be a sizable resource of mid-water fish.

CONCLUSION

The Wadge Bank is a rich Fishing ground from May to October. It requires vessels to withstand wind speed up to Beaufort 5°. The resources indicate the need for diversified fishing like pelagic trawling, squid jigging and line fishing in the rocky area. There is need for research on craft and gear and oceanographic studies on causes of migration and areas from which the fishes particularly the larger carangids migrate. Any fall in the economic catch rate has to be watched before a large number of vessels are introduced. Bobbin trawling might change the environment which has to be carefully watched as causes of migration are not known.

REFERENCES

- E. F. P. 1982 & 83. Results of the Exploratory survey of fisheries resources of Wadge Bank. Prog Rep. 1, 2, & 3, 26, 34 pp. 25.
- MENDIS, A. S. 1965. Resources of the Wadeg Bank and Pedro Bank, Bull. Fish. Res. Stn. Ceylon. Vol. 18 (2) 48-51.
- MITRA G. N. 1971. Resources Survey of Ceylon Fisheries. (Un-pub).
- F. S. I. 1917. Demersal Fishery Resources of Wadge Bank. Bull. Fish. Sur. of Ind. Jan. 1987.
- SIVALINGAM, S. & MEDCOF. General features and Productivity of the Wadge Bank. Trawl Fish. Bull. Res. Stn. Ceylon No.6.
- SIVALINGAM, S. 1969. Wadge Bank Trawl Fishery Studies. Part IV, Bull. Fish. Res. Stn. Vol. 20 pp. 29-50, pp. 51-64.

RESEARCH IN MARINE FISHERIES MANAGEMENT AND DEVELOPMENT – CAPTURE AND CULTURE FISHERIES

P. S. B. R. James, K. C. George and N. Gopalakrishna Pillai
Central Marine Fisheries Research Institute, Cochin.

ABSTRACT

The paper deals with the research contributions of the Central Marine Fisheries Research Institute for the management and development of marine capture and culture fisheries of the country during the past four decades.

The development of a stratified random sampling method for estimating the marine fish landings from the mostly artisanal type of fishing; the assessment of stock magnitudes of several exploited commercial species and underexploited potential resources have been the major contributions in the field of capture fisheries.

Apart from routine monitoring of the environmental parameters influencing the abundance and availability of commercial stocks, the Institute undertook studies in basic problems like upwelling, organic production and pollution.

Concurrent problems arising out of increasing mechanisation of fishing such as impact of purse seining on pelagic fishes and other schooling fishes like cat fishes and shrimp production have been studied and concerned states have been given appropriate advices.

In the culture sphere success has been achieved in breeding commercially important penaeid prawns, oysters and mussels under controlled conditions and maintenance of brood stocks, for raising seeds in the hatcheries. Techniques of pearl culture, edible oyster, mussel and sea weed culture have been perfected for local conditions.

By the systematically planned research activities since 1947, the Institute built up a firm foundation for marine fisheries development in the country on modern lines and generated base line information for the rational exploitation and management of the marine fishery resources of the country.

INTRODUCTION

The need for research support for Management actions in respect of renewable living resources like the fisheries is well known. Countries all over the world with developed

domestic and high sea fisheries have strong research inputs to back up their development and administrative policies.

As an important step for organising the sea fisheries of India on a sound footing, the

Central Marine Fisheries Research Station, later designated Institute, was established in 1947. During the last four decades this establishment made its contributions to help in the management of the marine fisheries of the country and its development on modern lines.

The main objectives set forth for the Institute have been to conduct investigations which would lead to estimation of marine fishery resources; to gather detailed information on the individual species of fishes of commercial importance, their potential, rational exploitation and conservation and also to study such environmental factors which are likely to influence the nature and magnitude of these fisheries. As the national priorities in the fisheries sector were undergoing reorientation, since the early 70's, with the emphasis on mariculture and exploitation of the resources of the Exclusive Economic Zone, the basic objectives underwent modification to cater to the needs of the industry and development agencies.

The main objectives of the Institute for the VIth Plan period have been redefined as under:

- i. to conduct research for assessing and monitoring the exploited marine fisheries resources leading to rational exploitation and conservation;
- ii. to assess the underexploited and unexploited marine fisheries resources of the Exclusive Economic Zone;
- iii. to understand the fluctuations in abundance of marine fisheries resources in relation to changes in the environment by conducting vessel based programmes;
- iv. to develop suitable mariculture technologies for finfish and shellfish in open sea to supplement marine fish production; and
- v. to conduct transfer of technology and post-graduate and specialised short term training programmes.

The Institute strived to achieve the above objectives in a systematic manner, even though for a long time since its inception, an ocean going research vessel of its own was not available. During the occasion of the 40th year of its establishment it is relevant to make a stock taking of the Institute's achievements and contributions to the development of marine fisheries of the country.

Assessment of Fishery Resources

The Institute developed a multi stage stratified random sampling design for the estimation of marine fish landings in the country at national and state levels. The design developed by the Institute has been recommended by the FAO for adoption by other developing countries. Resource wise and region-wise production estimates are made available to national and international organisations. Fish catch statistics and related data are collected from 62 zones and 20 single-centre zones covering the entire stretch of the 6100 km Indian coastline.

Based on the data on exploited resources collected in the past years, assessment of some of the commercially important fish stocks such as oil sardine, mackerel, Bombay duck, catfishes, tunas, prawns and cephalopods have been made.

Information on fishermen population, gears, crafts, employment details, educational standards and infrastructure facilities available in the marine fisheries sector have been collected periodically through frame surveys. The most recent census was conducted in 1980. This census data is widely used by the State and Central agencies for planning and developmental purposes.

For application of stock assessment models and proper interpretation of results, training course for personnel engaged in fisheries research and teaching have been taken up periodically. Training programme on the sampling design of CMFRI is also conducted for the benefit of personnel of Fisheries Departments of maritime states and Union Territories.

A very recent significant achievement has been the development of management advice for each maritime state based on analysis of data

collected on the exploited marine fisheries resources for 10 year period (1975-1984).

Pelagic Fisheries

The rate and pattern of exploitation of pelagic fish resources of the west and east coast of India have been studied by monitoring the landings from the artisanal, drift net and purse seine fisheries. Analysis of the data from exploratory cruises undertaken on a limited scale has provided information on the nature and extent of distribution of the pelagic resources beyond the presently fished grounds. These investigations have also brought to light the high potential of pelagic fish resources such as whitebaits, horse-mackerel and several mesopelagic fishes. Feasibility of exploitation of oceanic resources like tunas and related species have been highlighted.

Studies on the stocks of oil sardine (*Sardinella longiceps*) on the west coast of India indicated high potential (annual average stock size of 400,000 tonnes) and the possibilities of increasing the catches by stepping up fishing effort in the offshore grounds employing efficient fishing methods like purse-seining.

The stock assessment studied on Indian mackerel (*Rastrelliger kanagurta*) have revealed an average annual stock level of 265,000 tonnes off the south west coast of India (7°-17°N) and about one third of this stock is found beyond 25 m depth. Studies on the exploited resources indicate that any further increase in the catches should come from the offshore stocks or by increasing the age at capture by increasing mesh size.

A critical study of the exploited resources of the anchovies from Indian seas have revealed that species belonging to the genera *Stolephorus*, *Thryssa*, *Setipinna* and *Thrissina* are the main contributors in the order of abundance. Based on the productivity data and yield equation, a potential yield of 585,000 tonnes of anchovies was estimated for Indian waters. Since the present catch is very meagre compared to the potentials, substantial expansion of the fishery is recommended along the coasts of Kerala, Tamil Nadu and Andhra Pradesh for *Stolephorus* and *Thryssa*; along northern Maharashtra-Gujarat

sector for *Coilia* and along northern Orissa-West Bengal sector for *Setipinna*.

Studies on the stock assessment of Bombay duck, *Harpodon nehereus* revealed that at Nowabunder, Saurashtra coast, the present level of exploitation is close to the maximum sustainable yield and that any further expansion in the fishery would result in the over-exploitation of the stocks. However higher sustainable yield is possible by increasing the size at capture.

The estimation of the fished stocks of the little tuna (*Euthynnus affinis*) and the frigate mackerel (*Auxis thazard*) indicated that their average annual stock levels were of the order of 206,000 and 7,700 tonnes. The exploitation rate was 0.5 for both the stocks, indicating that the two species are under exploited and a substantial increase of production is possible by increasing the fishing effort. In the case of the oceanic skipjack (*Katsuwonus pelamis*) and yellowfin tuna (*Thunnus albacares*), the exploitation rates were estimated at 0.64 and 0.85 and total mortality rates at 2.07 and 3.17 respectively. In view of the low exploitation rates as compared with the high rates of total mortality, it is emphasised that substantial increase in the production from these stocks is possible by increasing fishing effort.

Stock assessment studies on seerfishes off the Karnataka coast showed that it was under-exploited and an expansion in the fishery would result in increased production without affecting the stocks. The potential resources of horse mackerel consisted mainly of *Decapterus* sp. and *Megalaspis cordyla*. An average standing stock of about 34,400 tonnes was indicated for the southwest coast of India and the Gulf of Mannar. The bulk of this biomass was located in 20-75m depth in Gulf of Mannar and 50-100 m depth in the south west coast. An extension of the distribution of the above species along the N.W. coast has been indicated by the M. T. *Maurena* surveys conducted in 1977. Based on the present level of exploitation of these stocks a substantial increase in the catches by the expansion of the fishing is possible. Studies on the stocks of ribbon fishes (mainly *Trichiurus lepturus*) of Andhra-Tamil Nadu and Kerala-Karnataka coast indicated that these resources were under-

exploited and greater fishing effort may be applied to get increased yield from the stocks. Special studies are undertaken on the marine phase of Hilsa along the coastal waters of Orissa and West Bengal.

Demersal Fisheries

Studies on demersal fish resources of the west and east coasts of India have been based on the close monitoring of the exploited fisheries by the artisanal sector using the traditional gear and also the mechanised sector of small and medium-sized boats using bottom trawls, bottom-set gill nets or hooks and lines.

During the 1949-55 period the ground fish resources studies were conducted based on exploratory fishing by large trawlers of the Government of India Deep Sea Fishing Station and the New India Fisheries Co. in the Bombay-Saurashtra waters. With the expansion of exploratory fishing programmes by Government of India vessels and the setting up of additional bases along the east and west coast, exploratory surveys and the demarcation of the trawlable areas and productive grounds continued, until nearly all grounds up to 50 m depth were covered. The delineation of the good grounds for sciaenids of Kutch, Dwaraka and Porbunder, for eels off Bombay and Cambay, for prawns, nemipterids and perches off the south west coast; silverbellies off southwest coast and catfishes off north east coast emerged out of the analysis of these fishing results by the CMFRI.

The deep shelf and slope off the S. W. coast were particularly studied, based on exploratory cruises of the vessels of the Government of India and the Integrated Fisheries Project. This brought forth much valuable information on the deepsea prawn and lobster resources near the shelf edge and slope, the perch fishing grounds along the rocky areas at 70-100 m depths and the enormous potential of the bathy pelagic fish complex in the shelf slope and beyond.

With the declaration of the EEZ the need arose to explore the farther reaches of the shelf in greater detail. The first move in this direction was the comprehensive, year-long Indo-Polish Industrial fishery survey and the detailed analysis

of the fishery and environmental data that followed in the late seventies. The study covered mainly the northwest zones, from 15° to 24°N (55 to 360 m depth). Abundance of threadfin breams at 125-360 m depth, serranids and larger carangids in 90-125 m ribbon fishes, pomfrets, horse-mackerel and eels in the 55-90 m depths were observed by the vessel.

In addition to such over-all studies and charting out of the productive fishing grounds of the demersal fisheries resources, detailed investigations on individual fish species/groups that contributed to major commercial fisheries, chiefly catfishes, threadfin-breams, silver bellies, sciaenids, perches, eels, flatfishes and lizardfishes have also been made. The estimations on the fished stocks of the five species of catfish *Tachysurus thalassinus*, *T. tenuispinis*, *T. serratus*, *T. dussumieri* and *Osteogobius militaris* have indicated that, except for the last mentioned, all species are at present under heavy fishing pressure and either the pressure has to be reduced or the size of fish caught increased, if the fisheries are to be sustained.

Stock assessment studies carried out on *Nemipterus japonicus* off Kakinada revealed that any increased effort on the presently fished stocks at the present size of capture would only result in lesser yield. However, at Madras, the stock is not fully exploited and greater fishing effort may be applied to get increased yield without adversely affecting the stock.

Investigations on the presently exploited demersal resources have shown that with the rapid development of the mechanised trawling in recent years, many of the inshore fisheries are under heavy pressure and damage to stock can be avoided only with a decrease in fishing effort or increasing the mesh size of gear used. This has great relevance to future development plans on marine fishery resources.

Crustacean Fisheries

The rapid expansion of the export market for prawns and the consequent introduction of large number of small mechanised boats for prawn fishing necessitated a concerted effort by the Institute to study the prawn fisheries on an all India basis. A wealth of information was

collected on the distribution and the abundance of the prawn species in space and time, growth, feeding habits, fecundity, sex ratio, and movements. Life cycles and juvenile phase of prawns in brackishwater environment have been studied in detail.

The deep sea lobster (*Puerulus sewalli*) and the deep sea prawn resources of the southwest coast of India were studied in detail. A total of 22 species of deep sea prawns have been observed in the catches. *Heterocarpus woodmasoni* forms the mainstay of the fishery. Relatively high concentration of prawn exists on the "Quilon Bank" at 301-375 m depth zone and in slightly deeper areas off Ponnani, on the upper continental slope. The potential resources of deep-sea prawns that could be commercially exploited from the "Quilon Bank" have been estimated to be about 5,300 tonnes from a productive area of about 5000 sq. km.

Realising the fact there has been some economic over-fishing for prawns in certain sectors of our coast, detailed stock assessment studies of important prawn species have been made. Using the data on catches and fishing effort collected over a period of ten years the magnitude of the prawn resources, the maximum sustainable yield and corresponding optimum fishing effort were estimated for nine important fishing centres, namely Saseen Dock in Bombay, Karwar, Mangalore, Calicut, Cochin, Sakthikulangara, Mandapam, Madras and Kakinada. The estimates showed that increasing the fishing effort beyond the optimum level is not likely to increase the prawn yield from all these centres, except Kakinada. In Kakinada there is a possibility of increasing the yield by putting in more fishing effort.

Based on the abundance and distribution of prawn seed in the estuaries and backwaters, attempts are being made to forecast the prawn fishery at sea.

Intensive tagging programme coupled with drift bottle studies showed that the tagged white prawns *Penaeus indicus* migrated from Cochin on the southwest coast to Tuticorin on the east coast following the coastal currents. They completed this 380 km journey in 68 days at an

average speed of 5.6 km per day. This study also showed that the prawns grew from a size of 110 mm to 149 mm during this period

Apart from the intensive studies on the prawn resources of the country the other crustacean resources such as rock lobsters, crabs and stomatopods have also been the subject of study.

Molluscan Fisheries

An inventory of the molluscan resources such as clams, oysters and mussels has been made covering the entire mainland coast as well as the Andaman and Nicobar Island.

The clam resources of the estuaries in Karnataka and Kerala have been investigated in detail in the context of recent spurt in the export of clams including baby clams. The commercially important species identified are *Meretrix meretrix*, *M. casta*, *Katylsia opima*, *Paphia*, spp. and *Villorita cyprinoides*. Such resource survey have also been carried out on green mussel *Perna viridis* and brown mussel *P. indica*, along the west coast. The standing stock of *P. indica* was estimated at 1610 tonnes (1933-84), while the landings were only 556 tonnes along the southwest coast.

The molluscan resources of Kakinada Bay, along the east coast, particularly those of the blood clam *Anadara granosa* and windowpane oyster *Placenta placenta*, were surveyed in detail and the potential for further development indicated. Underwater surveys of the pearl banks of the Gulf of Mannar using SCUBA equipments and assessment of the population of pearl oysters (*Pinctada fucata*) and chanks (*Xancus pyrum*) in the natural beds were made. These surveys helped in predicting the pearl and chank fisheries in the region.

The vast potential resources of oceanic squid *Symplactoteuthis ovalaniensis* in EEZ of India have been indicated based on the exploratory survey results of FORV *Sagar Sampada*. Resource characteristics and stock assessment of most of the commercially important species of *Loligo* and *Sepia* have been made.

Fishery Environment Management

The study of fishery related environmental factors which received considerable attention were initially confined to the coastal belt. Since late fifties, facilities of the Indo-Norwegian Project's vessels have been availed to study the oceanographic features of the entire shelf and the Lakshadweep. Better understanding of the seasonal phenomenon such as upwelling and dynamics of the mud bank formation resulted from these studies.

Estimates of the potential fish resources were made for the first time in the country on the basis of primary productivity studies using C^{14} technique.

Studies on marine mammals and turtles were taken up from a conservation angle with repeated seasonal observations on the 'Aribada', the mass nesting of turtles at Gahirmatha beach in Orissa. Surveys and ecological studies in connection with establishment of a marine national park in the Gulf of Mannar were completed. Studies on ancillary resources like corals, sponges, echinoderms and seaweeds contributed to development of resource data on these. Studies on marine pollution and bioactive agents in marine organisms received attention in the programmes of the Division.

In recent years the Institute collaborated with Space Application Centre, Ahmedabad and National Remote Sensing Agency, Hyderabad, in Joint Experiments for the utilization of satellite data to locate areas of high productivity in the EEZ. The studies using an Ocean Colour Radiometer indicated that chlorophyll densities, an index of the bioproductivity, could be mapped and used as indices of fisheries potential.

Other studies include secondary production and its relationship to the distribution of fishes; qualitative and quantitative abundance of fish eggs and larvae; distribution of the Antarctic Krill; isolation and mass culture of uni-cellular algae for hatchery development of different larvae; ecology of mangrove areas and their

influence on the fishery resources; coral resources and behaviour of reef fishes; formation and environmental characteristics of the mud banks of Kerala.

In addition to the national programme of tagging prawns and fishes to study their migration and growth, drift bottle experiments were under taken to understand the coastal drifts that aid the migration of these groups. A systematic programme of release of drift bottles from different centres along the east and west coast have resulted in recoveries which indicate a general southward drift of coastal current during the summer months, February to March. The recovery of drift bottles from the Sri Lanka coast and Somali coast is worth mentioning.

Fishery Economics and Extension

With increasing emphasis on the utilization of the resources of Exclusive Economic Zone and the formulation of integrated rural development programmes in mariculture, a whole range of economics of operations of both capture and culture fisheries and also socio-economics of fisherfolk has gained considerable importance.

Investigations carried out to assess the impact of large scale introduction of commercial purse-seining in Karnataka coastal waters showed that even though the total catches increased through purse-seining, the traditional Rampani operators suffered a severe economic set-back. The Institute recommended several remedial measures like providing Rampani owners with purse-seines through liberal Government loans and giving priority for Rampani operators as crew-members of purse-seiners.

Through a number of case studies, the socio-economic aspects of fishermen families in Kerala, Maharashtra and Gujarat have been investigated and the attention of institutional agencies was drawn to play a more dynamic role as credit agencies to the fishermen, so as to save them from the harassment of middlemen. The Institute has also conducted studies on the

economics of different types of fishing units, especially the traditional crafts fitted with outboard motor, marketing aspects such as price spread at various levels and also the role of women in small-scale fisheries activities. Projects aimed at evaluation of economic returns in mariculture operations have also been undertaken in recent years.

Physiology, Nutrition and Pathology

Since 1982, the Institute took up appropriate multi-disciplinary programmes on physiology, nutrition and Pathology of fish and shellfish, which formed either complementary or supplementary effort to the major ongoing research programmes in mariculture. The current programmes concentrate on problem oriented research such as, ecophysiology and respiratory physiology of fishes and shellfishes, protein variation and nutritional requirements of prawns; reproductive physiology of grey mullets; nutritional needs of milkfish and survey of finfish and shellfish diseases and pathology of soft prawns. Studies indicate that keeping the pond environment healthy by proper management practices is the best way to prevent the occurrence of the soft prawn disease.

Mariculture

Prawn culture

The Institute took up experimental studies on various aspects of prawn culture since 1975 and all the commercially important species of penaeid prawns such as *Penaus indicus*, *P. monodon*, *P. semisulcatus*, *Metapenaeus dobsoni*, *M. monoceros*, *M. affinis*, *M. moyebi* and *Parapenaeopsis stylifera* have been made to spawn in the laboratory and their larvae reared up to the post larval stage under controlled conditions. Recently, similar success has been achieved in the case of *P. japonicus*, and *P. latissulcatus*. To feed the prawn larvae, indigenous methods for culturing live feed organisms such as diatoms, rotifers and cladocerans on a large scale were developed. The larval rearing

technique was improved and simplified. The Institute has by now evolved a totally indigenous, low cost technology for the hatchery production of penaeid prawn seed, specially suited to the Indian conditions.

To enable the interested entrepreneurs in setting up prawn hatcheries to supply seed to the rapidly expanding prawn culture industry in the country a manual entitled "Hatchery production of penaeid prawn seed" has been published by the Institute. Under the transfer of technology programmes the Institute recently initiated providing technical assistance to State Governments for establishment of hatcheries for production of prawn seed. The Institute also provides technical assistance to prawn farmers and development agencies for accelerating the programmes in prawn culture. Recently at Tuticorin, the scientists helped a private prawn farmer to culture prawns in salt pan areas and a record production of 1200-1600 kg/ha was obtained in a period of 4½ to 6 months.

A technique of artificial insemination of *Penaeus indicus* and *P. monodon* has been developed. This is a significant achievement that is basic to all future work on selective breeding of prawns for improving production in culture systems.

A searanching programme for *P. semisulcatus* in the Palk Bay to augment the natural stock of this species in the Bay has been initiated.

Employing scientific methods in the field culture of prawns, using laboratory reared post-larvae for stocking, a production rate upto 600 kg/ha/54 days has been obtained. A pelletised feed, compounded from locally available raw materials has been developed.

Culture of other shell fishes

Progress has been made in rearing the larvae of the crabs, *Scylla serrata* and *Portunus pelagicus* to the crab stage in the laboratory. Rapid increase in growth rate of cultured lobsters has been achieved by eye stalk ablation.

Indigenous technology for oyster and mussel culture

A significant breakthrough was achieved in developing indigenously the techniques of pearl culture, which led to the establishment of a commercial pearl culture project in India for the first time. Cultured pearls are produced through raft culture with a production rate of 60-70% in nucleus implanted oysters in 3 to 24 months. In order to repopulate the pearl banks of Gulf of Mannar, a sea ranching programme of pearl oyster seed produced in the laboratory has recently been initiated at Tuticorin.

Another major achievement has been the development of techniques for oyster seed production in hatcheries. Following the initial breakthrough of technology for pearl oyster seed production, the edible oyster seed is also produced on large scale in experimental hatchery. Similarly mussel has been brought under the hatchery technology development programmes. The problem of paucity of seed for large scale culture operations of economically important bivalve molluscs has been solved.

Open-sea mussel farming techniques developed at the Institute have given high production rates (10-15 kg of mussel per metre length of rope, equal to 60-70 tonnes/ha). Edible oyster farming technology has been established to produce 150 tonnes/ha/annum.

Fin fish culture

Experimental finfish culture had been part of the Institute's programme from the early years, at Mandapam. The culture programme was intensified and extended to other centres like Tuticorin, Madras, Calicut and Narakkal by mono- and poly-culture-techniques, in ponds, cages and pens. Milkfish and mullets have been reared successfully in ponds and pens. Preliminary studies with species of *Lethrinus*, *Epinephelus* and *Lates* at Mandapam and Tuticorin yielded promising results. Induced breeding experiments conducted on *Mugil cephalus* with H. C. G hormone along with

pituitary-gland extract have yielded encouraging results.

Seaweed culture

Experimental field cultivation of the agaro-phytes *Gracilaria edulis* and *Gelidiella acerosa* in the Gulf of Mannar showed that *Gracilaria edulis* grew to harvestable size within 60 days yielding 3 kg/Sq. m. *Gelidiella acerosa* attained the same rate of production in 75 days. This yield is about 3 times the rate of natural production.

Special Surveys of Lakshadweep group of Islands

In recent times, the Lakshadweep islands have been in the limelight owing to the special considerations shown by the Government of India towards its all-round development. The Institute had already contributed to the management of marine fisheries resources of the area and steps are now being taken to expand and intensify its research activities in the relevant fields.

A series of special surveys were conducted since January 1987, aimed at an overall assessment of various types of fishery and ancillary living resources and their potentials. Three teams covered 10 islands, from January to March '87 (Agatti, Amini, Androth, Bitra, Chetlet, Kadamat, Kalpeni, Kavaratti, Kitten and Minicoy) and collected valuable information on the resource potentials, status of the coral reefs and the traditional fisheries.

During the surveys, it was found that considerable damage had taken place to the coral reefs around Minicoy and certain other islands due to dredging, silting and sand mining.

Skipjack (*Katsuwonus pelamis*) and young yellowfin tunas (*Thunnus albacares*) constituted the major tuna resources exploited by the islanders by live-bait pole and line fishery. Tuna formed 85% of the total fish landings in the islands and Agatti and Bitra alone accounted for more than 60% of the total tuna catches.

There seemed to be no scarcity for live baits in the islands surveyed except in Amini and Kiltan. Over 15 species of live baits were observed during the survey. *Spatelloides delicatulus* and *S. japonicus* dominated among them.

The common food fishes other than tuna in the islands were sharks and rays, goat fishes, carangids, perches, barracudas, half beaks and filefish.

The survey results also indicated that over 70 species of ornamental fishes occur in these islands, of which 30 are exportable. The survey teams collected information on seaweeds, sponges, echinoderms, crustacean resources and other invertebrates and gathered interesting data on marine mammals and seabirds and locations which could be developed as marine parks.

Suitable recommendations have been made for the protection of the ecosystem and development of fisheries.

Extended research programmes in the EEZ

CMFRI is the nodal organisation for the planning and execution of the research programmes of FORV *Sagar Sampada* of the Department of Ocean Development.

The vessel commenced its regular cruises from January 1985 and completed 33 cruises upto August 1987 spending 589 days at sea. A great deal of information on various fishery resources and related environmental parameters of the EEZ have been collected by the vessel.

The highlights of the results are the location of:

- The large deep sea prawn *Plesiopenaeus edwardsianus* at 870 m depth off Trivandrum.
- Spawning grounds of several species of fishes over the Angria Bank.

- Spawning/nursery grounds of ribbon fish off Veraval around 50m depth.
- Nursery ground of *Lactarius* at 100 m depth off Okha.
- Extensive swarms of oceanic crabs along the south-west during the south-west monsoon season.
- Large tuna shoals during post-monsoon time off Central west coast.
- Abundance of lobster larvae in the offshore waters (75 m) along Kerala-Karnataka coast in November.
- A variety of juvenile fishes, especially tunas in the Lakshadweep area in December-January and July-August periods, and dominant oceanic squid component in July-August.
- Large quantities of lantern fishes in the lower Bay of Bengal and equatorial region during Jan-February period.
- Confirmation of the phenomenon of the seasonal concentration of whitebaits in the Gulf of Mannar during the southwest monsoon season.
- Large concentration of threadfin bream, cuttlefish and squids in the Wadge Bank in August-September period.

These results are highly relevant for planning our future developmental programmes for exploiting the underexploited resources of the EEZ.

In conclusion it may be stated that the Central Marine Fisheries Research Institute by its planned activities during the past 40 years built up a firm foundation for marine fisheries development in the country and generated all base line information for the management of the resources.

It is by now fairly clear that the traditional fisheries can contribute only marginally to the augmentation of marine fish catches in the country. However, exploitation of these resources has to be carefully monitored and protected from the changes that may be taking place in the coastal environment. Conservation measures, where needed have to be developed based on sound scientific knowledge. Future research from vessel based programmes aims at understanding the fluctuations in abundance of commercially important species in relation to

environmental characteristics, development of forecasts for fisheries and assessment of stocks of under exploited or unexploited resources including the deep shelf resources and the virtually untapped resources like the oceanic tunas, squids and mesopelagic fishes should be our targets for exploitation for enhancing fish production. The CMFRI has set its direction in this regard by extending its research programmes to the boundaries of the EEZ for assessment of the potentials of these resources for their eventual commercial exploitation.