

FOR AERATING WATER MEDIA IN ACULTURE EXPERIMENTS

In

.

.

.

.

.

.

.

.

.

Airioxygen bubbling unit.

bubbles, and was used successfully in the experiments for holding *Stolephorus*, to be used as live-bait for tuna fishing, in large fibreglass tanks at the Vizhinjam Research Centre of Central Marine Fisheries Research Institute.

The technical help received from Shri George Koshy, Scientist, V. S. S. C, Trivandrum, in the initial stages of designing this equipment is gratefully acknowledged.

Description and working of the air\oxygen bubbling unit

The hose adaptor (Fig. 2, 1), a tube with serrations outside for holding the hose from the air\oxygen source, is attached to the main body of the bubbling unit by means of a tightening nut (2). The central adaptor (3), which is the main body of the unit, is a cylindrical hollow structure. One end of this adaptor is threaded and is fitted to the hose adaptor, and the other end, with a protruding M-12 threaded portion, is fixed to the grinding wheel (4). The grinding wheel is made of fine-graded Vitreous bond Aluminium Oxide and is porous (= A 800 M VG 2 of Carborandum Universal, which was used in this experiment). Both its flat surfaces having first coated with commercial

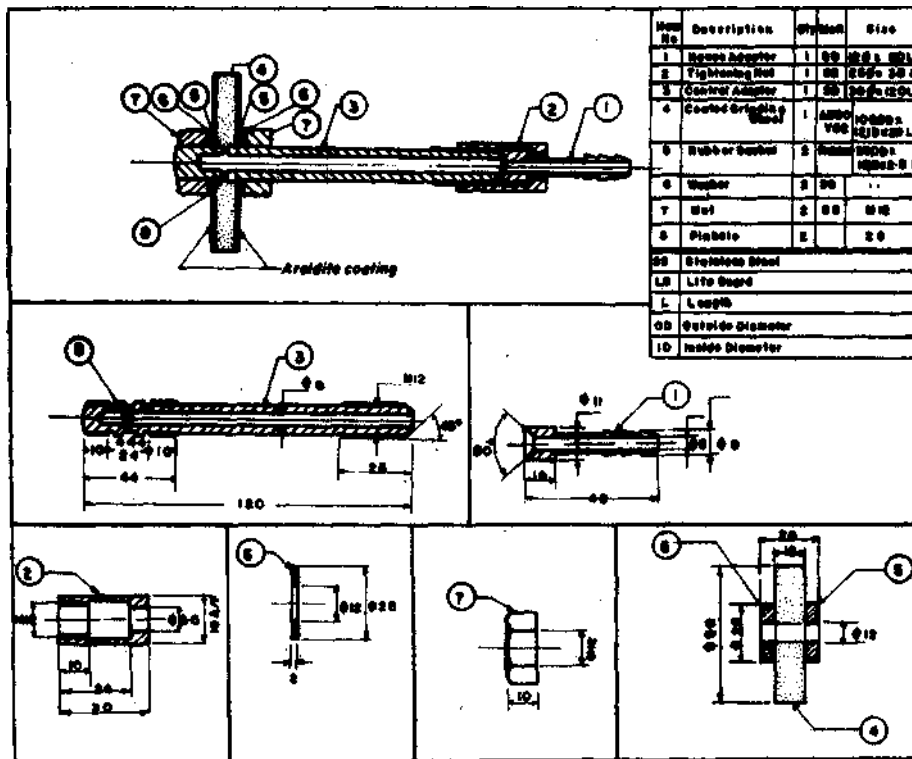

FIG. 2. Drawing of the cross-sectional view of the air\oxygen bubbling unit showing its parts (from 1 to 7). (All dimensions in mm, figures not to scale.)

araldite, the grinding wheel is fixed to the central adaptor at the pin holes' portion by means of a gasket (5), washer (6) and nut (7), on either side. The central adaptor, being hollow inside, allows the free flow of air|oxygen from the hose adaptor into the grinding wheel. The grinding wheel, being finely porous, ensures release of the air|oxygen in small bubbles. The rubber gasket provided on either face of the grinding wheel prevents leakage of air|oxygen at the joint between the grinding wheel and the central adaptor.

The air|oxygen under pressure when enters into the bubbling unit immersed in water passes through the central adaptor and, forcing through the pores of the grinding wheel, pours out as bubbles at its round surface. As the speed of bubbling is depending directly on the pressure of the inflow, the rate of aeration can be regulated by regulating the inflow.

The air|oxygen bubbling unit used in aerating marine or brackishwater tank is required to be rinsed in fresh water occasionally, lest it clog or corrode.

The cost consciousness of the bubbling unit, made up of different materials, is as follows.

<i>Type of material</i>	<i>Cost per unit (excluding the cost of grinding wheel)</i>
Stainless steel	Rs. 3001-
Brass Coated with Nickal	Rs. 230 -
Brass	Rs. 2051-
P.V.C.	Rs. 108 -

BALDWIN, W. J. 1970. *J. Fish. Res. Board Can.*, 27: 1172-74.